

KLS martin
GROUP



Plastische Chirurgie
Plastic Surgery
Cirugía plástica
Chirurgie plastique
Chirurgia plastica

Plastic

Chirurgische Instrumente



Seit 1923



Surgical Innovation is our Passion



Chirurgische Innovation ist unsere Leidenschaft

Wie kommt man dazu, über 12.000 chirurgische Instrumente zu entwickeln, zu fertigen und zu vermarkten? Produkte, die sich durch klare Alleinstellungsmerkmale auszeichnen. Es ist die Leidenschaft, neue Wege zu finden, die Menschen helfen und der Gesundheit dienen.



EN

Surgical Innovation is our passion

What is the secret behind the development, manufacture and distribution of over 12,000 exclusive surgical instruments, products whose distinguishing characteristics truly set them apart from all the others? The answer is passion, the overwhelming desire to discover new ways of serving humankind in its search for ultimate health.

ES

La innovación quirúrgica es nuestra pasión

¿Cómo es posible concebir, producir y comercializar más de 12.000 instrumentos quirúrgicos? Estamos hablando de productos que se caracterizan por unas propiedades exclusivas, claramente definidas. La clave está en que nos motiva la pasión por encontrar nuevos caminos para ayudar a las personas y fomentar la salud.

FR

Notre passion est l'innovation chirurgicale

Comment est-il possible de développer, fabriquer et commercialiser plus de 12.000 instruments chirurgicaux ? Des produits dont les caractéristiques distinctives sont leur position unique sur le marché. Et bien, ceci est en fait dû à la passion de vouloir trouver de nouvelles méthodes afin de venir en aide aux personnes et de servir la santé.

IT

L'innovazione nella chirurgia è la nostra passione

Che cosa ci spinge a progettare, produrre e distribuire più di 12.000 strumenti chirurgici dalle caratteristiche uniche? Sono la nostra passione e il desiderio di aiutare il prossimo e cercare nuove vie per migliorare la salute.



Am Anfang stand die Vision, aus kleinen Firmen eine international agierende Unternehmensgruppe zu bilden. Das war 1923. Heute beschäftigt die KLS Martin Group über 1.300 Mitarbeiter und ist einer der weltweit führenden Konzerne für Entwicklung, Produktion und Vertrieb medizintechnischer Produkte, die in enger Zusammenarbeit mit denjenigen entwickelt werden, die sie letztlich einsetzen: den Chirurgen.

EN

In the beginning there was a vision

Our vision, in 1923, was to create an internationally operating group of companies from a handful of smaller businesses. Today, the KLS Martin Group has a staff of over 1,300 and is one of the leading globally acting enterprises for the development, manufacture and distribution of medical devices. We work hand in hand with those holding the scalpel: the surgeons.

ES

Todo comienzo parte de una visión

Al principio la visión consistía en conformar, a partir de pequeñas empresas, un grupo empresarial con intervención a escala mundial. Corría el año 1923 en aquel entonces. Hoy en día, el KLS Martin Group da trabajo a más de 1.300 personas y se encuentra a nivel mundial entre los consorcios líderes dedicados al desarrollo, producción y comercialización de productos medicotécnicos, diseñados en estrecha colaboración con aquel grupo de personas que finalmente los emplean: los cirujanos.

FR

Tout commença par une vision

Au début, en l'an 1923, naquit la vision de pouvoir former un groupe d'entreprises à activités internationales à partir de petites entreprises. Le groupe KLS Martin Group occupe actuellement plus de 1.300 employés et il est l'un des groupes leaders sur le marché mondial dans le secteur du développement, de la production et de la commercialisation de produits médico-techniques, ces produits ayant été développés en étroite collaboration avec ceux les utilisant, c'est-à-dire les chirurgiens.

IT

All'inizio c'era una visione

All'inizio c'era una visione: fondere piccole ditte per creare un gruppo aziendale operante a livello internazionale. Era il 1923. Oggi il KLS Martin Group ha più di 1.300 dipendenti ed è una delle imprese leader al mondo nella progettazione, produzione e distribuzione di prodotti medicali creati in stretta collaborazione con gli utenti finali: i chirurghi.

Am Anfang
stand eine Vision





Qualitätssicherung ohne Kompromisse

Unsere Produkte erfüllen den Anspruch anwendungsbezogener Funktionalität, intelligenter Handhabung und hoher Qualität. Und wenn es um die Erfüllung dieses Anspruchs geht, machen wir keine Kompromisse. Um dies zu gewährleisten, unterhält KLS Martin ein eigenes hochmodernes Labor sowie ein Technikum, in denen die Qualität unserer Erzeugnisse – auch unter extremen Bedingungen – auf „Herz und Nieren“ getestet und dokumentiert werden.

EN

Quality assurance uncompromising

Our products are designed to consistently meet high demands for application-oriented functionality, intelligent operation and top quality. And we are not prepared to compromise when it comes to meeting the justified expectations of our customers, present and future – your standards become ours. KLS Martin runs their own ultramodern laboratories and a pilot plant, where our products are stress-tested under extreme conditions – every step is documented before release.

ES

Un seguro de calidad sin compromisos

Nuestros productos cumplen el requisito de estar dotados de la funcionalidad conforme a su aplicación, su manipulación es inteligente y son de alta calidad. No transigimos a la hora de cumplir con estas condiciones esenciales. Por este motivo, KLS Martin mantiene un laboratorio propio, altamente moderno, así como una escuela técnica, donde se ensaya y documenta la calidad de nuestros productos – inclusive bajo condiciones extremas –, examinándolos “hasta la médula”.

FR

Une assurance qualité sans compromis

Nos produits répondent aux exigences requises par une fonctionnalité relative à l'application, un maniement intelligent et une qualité élevée. Et nous n'acceptons aucun compromis lorsqu'il s'agit de répondre à ces exigences. KLS Martin possède à ce but son propre laboratoire ultramoderne et son centre technique dans lesquels la qualité de nos produits fabriqués est testée minutieusement – même sous des extrêmes conditions – et les résultats des tests sont documentés.

IT

Assicurazione della qualità senza compromessi

I nostri prodotti sono stati progettati guardando alle esigenze della prassi applicativa, offrono una manipolazione intelligente e sono di qualità elevata. A tale riguardo non facciamo compromessi. Per garantire questo standard, KLS Martin ha un laboratorio altamente moderno e un centro tecnologico in cui controlla e documenta la qualità di tutti i prodotti, anche in condizioni estreme.

Wir setzen Standards für die Instrumentenaufbereitung

Wie lassen sich Medizinprodukte vor mechanischer, thermischer oder chemischer Belastung schützen? Was muss man bei der Aufbereitung und Pflege besonders feingliedriger Mikrochirurgie-Instrumente berücksichtigen? Als Mitglied wichtiger Gremien und Arbeitskreise – wie z. B. dem Arbeitskreis Instrumenten-Aufbereitung AKI – gibt KLS Martin Antworten und erarbeitet Lösungen für die optimale Aufbereitung und Pflege von Instrumenten. Von der Auswahl angemessener Reinigungsverfahren bis hin zu Sterilisationsverfahren.

EN

Standards and best practice: instrument preparation

How best to protect surgical instruments from mechanical, thermal and chemical stresses? What steps are performed to ensure optimal preparation and care of highly delicate microsurgical instruments? KLS Martin, in their capacity as member of important advisory boards and working groups – for example, Working Group Instrument Preparation AKI – is in a position to provide answers and solutions to all inquiries with regard to the optimal preparation and care of instruments, ranging from knowledgeable advice on appropriate cleaning methods through sterilization processes.

ES

Los estándares y la mejor práctica para la preparación de instrumentos

¿Cómo se pueden proteger los productos médicos contra la actuación de factores mecánicos, térmicos y químicos? ¿Qué es lo que hay que considerar en el momento de preparación y cuidado del instrumental microquirúrgico, constituido fundamentalmente por componentes finos? En función de miembro de asociaciones y comités laborales importantes – como por ejemplo, el Comité Alemán de Trabajo de Preparación de Instrumental AKI – KLS Martin ofrece respuestas y elabora soluciones para el tratamiento y cuidado óptimos del instrumental. Éstas abarcan desde la selección de métodos de limpieza adecuados hasta el procedimiento de esterilización.

FR

Normes et pratiques idéales pour la préparation des instruments

Comment protéger les produits médicaux contre d'éventuelles contraintes mécaniques, thermiques ou chimiques? Quels points doivent être pris en considération pour le traitement et l'entretien d'instruments micro-chirurgicaux à fine ossature? A titre de membre d'importants organismes et cercles de travail, tels que par exemple l'AKI (Arbeitskreis Instrumenten-Aufbereitung = cercle de travail pour le traitement des instruments), KLS Martin donne des réponses et élabore des solutions pour assurer un traitement et un entretien optimaux des instruments. Depuis la sélection de procédés de nettoyage adéquats jusqu'au procédé de stérilisation.

IT

Standard e “best practice” per la preparazione degli strumenti

Come si possono proteggere gli strumenti medici da agenti aggressivi di tipo meccanico, termico o chimico? Cosa occorre tenere presente nella preparazione e nella manutenzione di strumenti microchirurgici particolarmente delicati? Quale membro di importanti organi e gruppi di lavoro, come ad esempio AKI, il gruppo tedesco di lavoro per la corretta preparazione degli strumenti, KLS Martin dà risposta e sviluppa soluzioni per la preparazione e la manutenzione ottimali degli strumenti, dalla scelta dei sistemi di pulizia più idonei alle procedure di sterilizzazione.



Wir bieten Ihnen die Möglichkeit, zu Ihrem KLS-Martin-Produkt die passende Gebrauchsanweisung digital anzufordern.

Gebrauchsanweisung anfordern

Anrede

Titel



Lebenslange Garantie
für MARTIN-Instrumente



Lebenslange Garantie – wann immer Sie sie brauchen

Keine Frage, wir sind stets auf der Suche nach der noch besseren Lösung. Das zeichnet den kontinuierlichen Fortschritt in unserem Produktportfolio aus. Gleichwohl sind alle unsere Instrumente qualitativ erstklassig und werden höchsten Ansprüchen gerecht. Und weil wir davon überzeugt sind, gewähren wir auf jedes Instrument bei sach- und fachgerechtem Einsatz eine lebenslange Garantie.

EN

Whenever you need it – our lifetime guarantee

Our determined and ongoing search for the perfect solution is reflected in the dynamic nature of our product portfolio. You simply will not find better instruments on the market. And because we truly believe in the outstanding quality of our products, we offer a lifelong guarantee on each instrument, in connection with appropriate and professional use.

ES

Necesite lo que necesite – la garantía es de por vida

Lo cierto es que siempre estamos en la búsqueda de una solución que sea aún mejor. Esto es lo que determina el progreso continuado de nuestra cartera de producción. Todos nuestros instrumentos son de la misma calidad máxima cumpliendo, por lo tanto cumplan con los requisitos más exigentes. Y como estamos convencidos de ello, garantizamos en todo nuestro instrumental una garantía de por vida, siempre y cuando se utilice como es debido y según las normativas.

FR

Si jamais vous en avez besoin – notre garantie à vie

Nous sommes, sans aucun doute, toujours à la recherche de la solution optimale. Ce fait caractérise le progrès continu dans notre porte-feuille de produits. Tous nos instruments sont à la fois de toute première qualité et conformes à des exigences maximales. Et étant donné ce fait, nous garantissons sur chaque instrument une garantie à vie, à condition que les instruments soient utilisés de manière adéquate et compétente.

IT

Ogni qual volta ne avete bisogno – la nostra garanzia a vita

Essendo alla ricerca di soluzioni sempre migliori, i nostri prodotti vengono costantemente migliorati. Essi sono di qualità eccellente e soddisfano persino le esigenze più elevate. Per questo possiamo accordare una garanzia a vita per ogni strumento impiegato in modo appropriato e corretto.

Instrumente schneller finden – die Katalog-Handhabung

Es ist ganz einfach: Die Artikelnummer gibt Auskunft über Produkt, Produktgruppe und Größe/Figur des Instruments. Jedes Produkt wird in Größe und Funktion vollständig beschrieben sowie maßstabsgetreu abgebildet – die Arbeitsenden je im Verhältnis 1 : 1. So finden Sie schneller, was Sie wirklich brauchen.



EN

Finding the instruments you need – how to use the catalogue

Straightforward and easy: The article number informs you about the product, product group and instrument size. Size and function of each product are described in full detail and illustrated to scale – the working ends in a ratio of 1 : 1. You can quickly find exactly what you are looking for.

ES

Encuentre el instrumental que necesita – modo de consultar el catálogo

Es muy simple: El número de artículo facilita una información acerca del producto, el grupo de producto y el tamaño del instrumental. Encontrará la descripción completa de tamaño y función de cada producto y una ilustración a escala; los extremos funcionales aparecerán en relación 1 : 1. Así Ud. podrá encontrar más rápidamente lo que realmente necesita.

FR

Comment trouver les instruments requis – l'utilisation du catalogue

C'est tout simple : Le numéro d'article fournit des informations sur le produit, le groupe de produits et la taille de l'instrument. Une description détaillée de la taille et du fonctionnement de chaque produit est fournie et tous les produits sont illustrés à l'échelle – les extrémités des instruments étant illustrées au rapport 1 : 1. Ainsi vous trouvez plus rapidement ce dont vous avez vraiment besoin.

IT

Trovare gli strumenti che cercate – i cataloghi

È semplicissimo: Il codice articolo fornisce informazioni sul prodotto, sulla categoria e sulla grandezza dello strumento. Il catalogo presenta una descrizione dettagliata di ciascun prodotto, delle sue dimensioni e funzioni nonché un'illustrazione in scala degli strumenti, le cui estremità sono riprodotte in rapporto 1 : 1. In questo modo trovate più velocemente ciò di cui avete veramente bisogno.

Abbildungsmaßstab
Illustration scale
Los productos en escala
Produits à l'échelle
Prodotti dimensioni

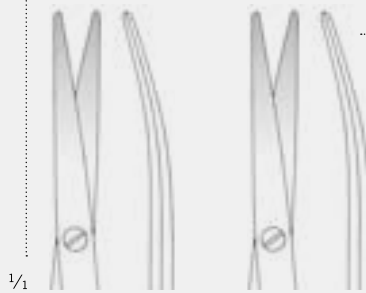

Arbeitsenden
Working end
El extremo funcional
del producto
Extrémité opératoire
du produit
L'estremità funzio-
nale del prodotto

Autor (wenn vorhanden)
Author (if available)
Autor (si lo hay)
Auteur (s'il existe)
Autore (se disponibile)

11-339-12-07
12,5 cm / 5"
feines Modell
fine pattern
modelo fino
modèle fin
modello delicato

11-339-18-07
18 cm / 7"
feines Modell
fine pattern
modelo fino
modèle fin
modello delicato

Salyer
11-339-12-07 –
11-339-18-07

Angaben zum Produkt
Product information
Datos sobre el producto
Données sur le produit
Indicazioni relative al
prodotto

für Lippen-, Kiefer-, Gaumenspalte
for Cleft Palate
para fisura paladar
pour fente du palais
per cheilo-labbro-palatoschisi

Maße
Dimensions
Dimensiones
Dimensions
Dimensioni

	Materialart	Material type	Tipo de material	Type de matériau	Tipo di materiale
01	Stahl 18/8 martinit, antimagnetisch, rostfrei, säurebeständig	steel 18/8 martinit, antimagnetic, stainless, acid-resistant	acero 18/8 martinit, antimagnético, inoxidable, resistente a los ácidos	acier 18/8 martinit, antimagnétique, inoxydable, résistant aux acides	acciaio 18/8 martinit, antimagnetico, inossidabile, resistente agli acidi
02	verchromt	chrome-plated	cromado	chromé	cromato
04	alle übrigen, nicht besonders gekennzeichneten Materialarten	all other, not specially marked material types	todos los otros tipos de materiales no identificados de forma especial	tous les autres types de matériau sans marquage spécial	tutti gli altri tipi di materiali senza marcatura speciale
07	rostfreier Stahl	stainless steel	acero inoxidable	acier inoxydable	acciaio inossidabile
08	Silber	silver	plata	argent	argento
09	Titan	titanium	titanio	titane	titanio
14	Solid Black	Solid Black	Solid Black	Solid Black	Solid Black
98	Ersatzteil	replacement part	pieza de repuesto	pièce de rechange	pezzo di ricambio

Erläuterungen zum Katalog

Catalog explanations

Explicaciones complementarias al catálogo

Explicacions sur le catalogue

Spiegazioni relative al catalogo



Verweis · Reference · Referencia
Référence · Rimando



Für Fig. Nr. · for fig. No.
para fig. No. · pour fig. No.
per fig. N.



Schneidenlänge · cutting edge length
longitud de hojas cortantes
longueur de lames · lunghezza di lame



Schnittlänge · cutting length
longitud de corte · longueur de coupe
lunghezza di taglio



Anzahl Zähne · number of teeth
cantidad de dientes · quantité de dents
quantità di denti



Anzahl Zinken · number of teeth
cantidad de dientes · quantité de dents
quantità di denti



Spreizweite · spreading width
extensión · écartement
apertura



Fadenstärke · thread size
grosor de hilos · grosseur de fils
spessore di fili



De Bakey
Zahnung · serration · dentado
denture · dentatura



Cooley
Zahnung · serration · dentado
denture · dentatura



Edelstahl · stainless steel
acero inoxidable · acier inoxydable
acciaio inossidabile



martinit-Stahl · martinit steel
acero martinit · acier martinit
acciaio martinit



Titan · titanium · titanio
titane · titanio



Aluminium · aluminum · aluminio
aluminium · alluminio



Silikon · Silicone
Silicona · Silicone · Silicene



Kaltlicht · cold light · luz fría
lumière froide · luce fredda



Solid Black
Hartstoffbeschichtung
(für eine längere Standzeit)
Hard-coated surface
(for extended life)
Recubrimiento con material duro
(para una vida útil más larga)
Revêtement à surface dure
(pour une durée de vie prolongée)
Rivestimento in materiale rigido
(per una più lunga durata)

TC GOLD

Instrumente mit Hartmetalleinlagen
Instruments with tungsten carbide inserts
Instrumentos con filos de carburo de tungsteno
Instruments avec plaquettes en carbure de tungstène
Strumenti con taglio in carburo di tungsteno

STERILE R

mit Gamma-Strahlen sterilisierte Produkte
with gamma radiation sterilized products
productos esterilizados con rayos gamma
produits stérilisés avec de rayons gamma
prodotti sterilizzati con raggi gamma

STERILE EO

mit Ethylenoxyd sterilisierte Produkte
with ethylene oxide sterilized products
productos esterilizados con óxido de etileno
produits stérilisés avec l'oxyde d'éthylène
prodotti sterilizzati con ossido di etilene



Diamantierte Arbeitsenden
Diamond-coated working ends
Extremos de trabajo diamantados
Extrémités de travail diamantées
Estremità operative diamantate



Safety-Wave-Sicherheitschluss
Safety-Wave safety pivot
Cierre de seguridad Safety-Wave
Fermeture sécurisée Safety-Wave
Arresto di sicurezza Safety-Wave



Counter Balance

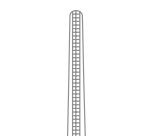

Atrauma-Zahnung
Atraumatic serration
Dentado atraumático
Dentelure Atrauma
Dentatura atraumatica

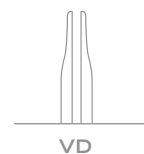

Gefäßdilatoren
Vessel dilators
Dilatadores vasculares
Pincas à dilatation de vaisseaux
Dilatatori vascolari

Übersichtstafel
Table of Contents
Tabla de catálogo
Contenu
Indice di catalogo



Übersichtstafel

Table of Contents

Tabla de catálogo

Contenu

Indice di catalogo

10

1-7

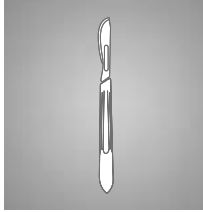

Skalpelle
Scalpels
Bisturíes
Bistouris
Bisturi

18

131-136

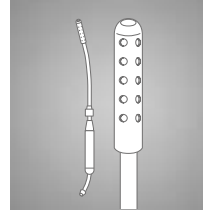

Sauger, Kanülen
Suction Tubes, Cannulas
Tubos de Aspiración, Cánulas
Tubes d'aspiration, Canules
Tubi d'aspirazione, Cannule

11

9-92



Scheren
Scissors
Tijeras
Ciseaux
Forbici

20

137-152



Naht
Suture
Sutura
Suture
Sutura

12

93-104

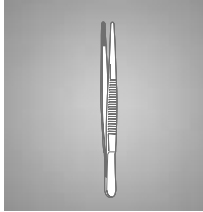

Pinzetten
Forceps
Pinzas
Pincers
Pinze

22

23

153-167

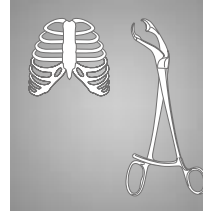

Knochenchirurgie
Bone Surgery
Cirugía ósea
Chirurgie osseuse
Chirurgia ossea

13

105-108



Arterienklemmen
Artery Forceps
Pinzas hemostáticas
Pincers hémostatiques
Pinze emostatiche

28

169-176

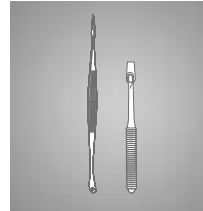

Spezialinstrumente
Special instruments
Instrumentos especiale
Instruments spécifiques
Strumenti speciali

15

109-125

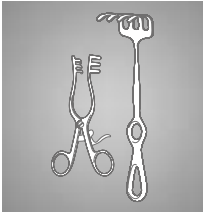

Wundhaken und Abhalter
Hooklets and retractors
Ganchitos y separadores
Crochets et ecarteurs
Divaricatori

35

177-178



Zirkel
Calipers
Compases
Compas
Compassi

17

127-129

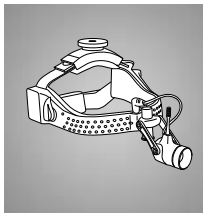



Diagnostik
Diagnostics
Diagnóstico
Diagnostic
Diagnostica

36

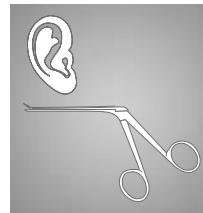
179-182

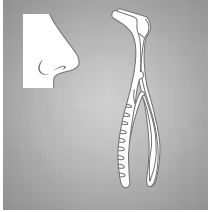
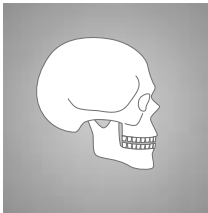
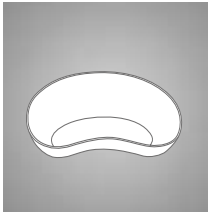
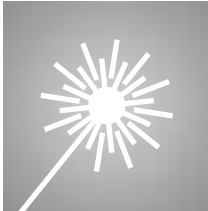
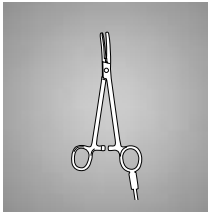

Otologie
Otology
Otología
Otologie
Otologia

37 183-216		Rhinologie Rhynology Rinología Rhinologie Rinologia
38-52 217-303		Mund-, Kiefer- und Gesichtschirurgie Oral and cranio-maxillofacial surgery Cirugía oral y maxilofacial Chirurgie orale et maxillofaciale Chirurgia orale e maxillofaciale
55 56 305-308		Verschiedenes Miscellaneous Diversos artículos Articles divers Articoli diversi
76-79 309-313		Laserchirurgie Laser Surgery Cirugía láser Chirurgie laser Chirurgia laser
80 315-335		HF-Chirurgie HF Surgery Cirugía AF Chirurgie HF Chirurgia AF
335-362		Index Index Indice Index Indice

Weitere Kataloge von KLS Martin

Zu den folgenden Produktgruppen sind jeweils eigene Kataloge verfügbar, die Sie gerne bei uns anfordern können:

Further catalogs of KLS Martin

For the following product groups additional catalogs are available. Please ask for your personal copy:

Más catálogos de KLS Martin

Para los grupos siguientes tenemos catálogos individuales disponibles. No duden pedirnos más ejemplares:

Autres catalogues de KLS Martin

Pour les groupes de produits suivants sont disponibles des catalogues additionnels dont vous pouvez demander le nombre désiré:

Altri cataloghi di KLS Martin

Per i gruppi di prodotti seguenti sono disponibili cataloghi addizionali. La preghiamo di informarci se desidera altre copie:

Deckenversorgungseinheiten
Ceiling-mounting systems
Unidades de alimentación de techo
Unités d'alimentation montées au plafond
Sistemi pensili

OP-Leuchten
Operating Theatre Lights
Lámparas de quirófano
Lampes opératoires
Lampade scialitiche

HF-Chirurgie
HF Surgery
Cirugía AF
Chirurgie HF
Chirurgia AF

Mund-, Kiefer- und Gesichtschirurgie
Oral and Craniomaxillofacial surgery
Cirugía oral y maxilofacial
Chirurgie orale et maxillofaciale
Chirurgia orale e maxillofaciale

Steriltechnik
Sterile Technology
Técnica de esterilización
Technologie stérile
Tecnica di sterilizzazione

Skalpelle
Scalpels
Bisturíes
Bistouris
Bisturi

10

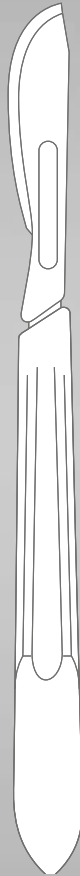

Modelliermesser

Modeling knife

Cuchillas para modelar

Couteaux modelar

Coltelli per mdellare



Nagata
10-040-01-07

12 cm / 4 $\frac{5}{8}$ "

Modelliermessergriff, klein
Modeling knife handle, small
Mango tallador, pequeño
Manche pour modeleur, petit
Manico coltello modell., piccolo



Nagata
10-040-02-07

12 cm / 4 $\frac{5}{8}$ "

Modelliermessergriff, groß
Modeling knife handle, big
Mango tallador, grande
Manche pour modeleur, grand
Manico coltello modell., grande

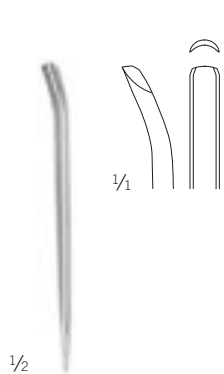

Nagata
10-040-03-07

3,0 mm

Modelliermesser Klinge
Modeling knife blade
Cuchilla tallador
Lame de modeleur
Lama coltello modell.

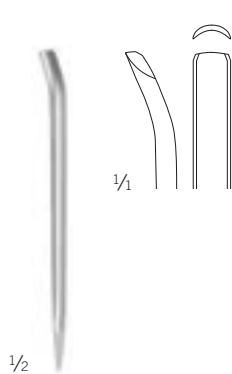

Nagata
10-040-04-07

4,5 mm

Modelliermesser Klinge
Modeling knife blade
Cuchilla tallador
Lame de modeleur
Lama coltello modell.

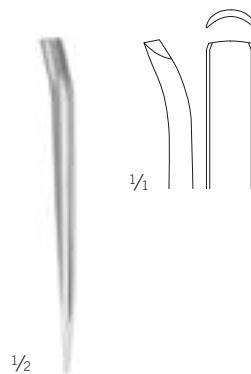

Nagata
10-040-05-07

6,0 mm

Modelliermesser Klinge
Modeling knife blade
Cuchilla tallador
Lame de modeleur
Lama coltello modell.

Skalpellgriffe

Scalpel Handles
Mangos de bisturí
Manches pour bistouris
Manici per bisturi

Skalpelle

Scalpels
Bisturíes
Bistouris
Bisturi

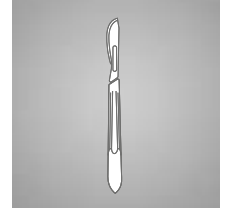

10



10-096-00-07

Rasierklingen
brechbar
Packing mit 10 Stück
Razor Blades
breakable
package with 10 units
Hojas de afeitador
rompeable
paquete con 10 unidades

Lames de rasoir
cassable
boîte de 10 lames
Lamette da rasoio
rompibile
scatola di 10 lamette



 Fig. 18 - 36

Nr. 4L



 Fig. 18 - 36

Nr. 8



 Fig. 10 - 17

Nr. 3



 Fig. 10 - 17

Nr. 3L

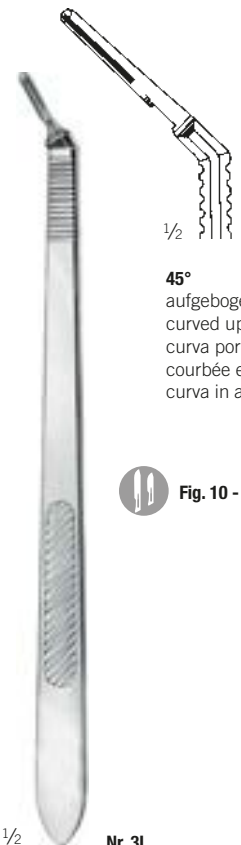

 Fig. 10 - 17

Nr. 3L

1/2
45°
aufgebogen
curved upwards
curva por arriba
courbée en haut
curva in alto

10-104-41-07

21 cm / 8 2/8"

massiv
solid
macizo
solide
pieno

Collin

10-108-08-07

13,5 cm 5 3/8"

mit Hohlheft
with hollow handle
con mango hueco
avec manche creux

10-130-03-07

12 cm / 4 6/8"

massiv
solid
macizo
solide
pieno

10-133-31-07

21,5 cm / 8 4/8"

massiv, lang
solid, long
macizo, largo
solide, long
pieno, lungo

10-133-35-07

20,5 cm / 8 1/8"

massiv, lang
solid, long
macizo, largo
solide, long
pieno, lungo

Skalpellgriffe

Scalpel Handles

Mangos de bisturí

Manches pour bistouris

Manici per bisturi

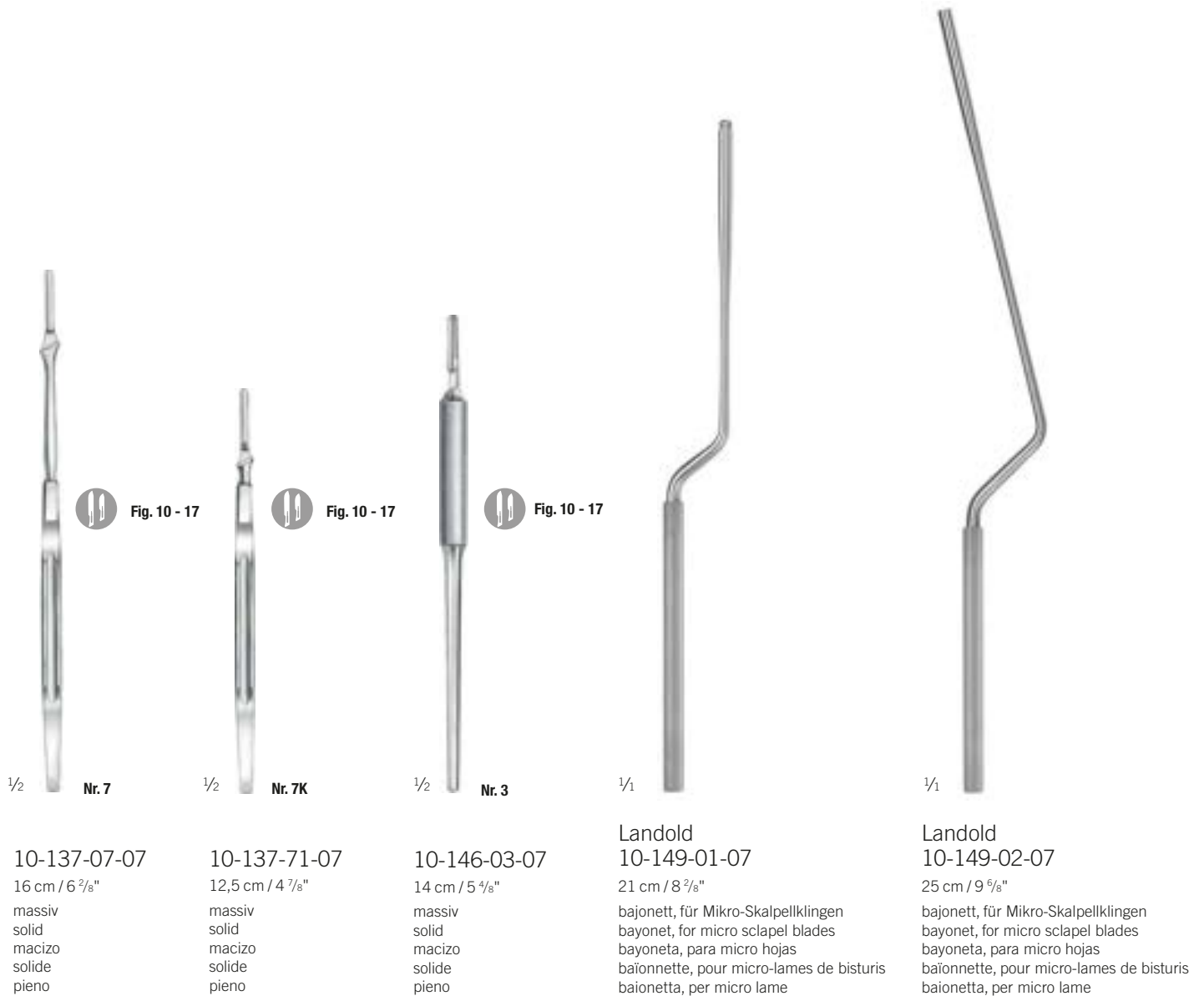

Skalpellgriffe

Scalpel Handles
Mangos de bisturí
Manches pour bistouris
Manici per bisturi

Skalpelle

Scalpels
Bisturíes
Bistouris
Bisturi

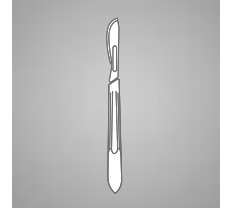

10



1/1

10-149-03-07

22,5 cm / 8 7/8"

schlankes Modell
slender pattern
modelo delgado
modèle gracile
modello delicato



1/1

10-149-05-07

21 cm / 8 2/8"

bajonett
bayonet
bayoneta
baïonnette
baionetta



1/1

10-149-06-07

15,5 cm / 6 1/8"

Mini, rund, für Mikro-Skalpellklingen
Mini, round, for micro scalpel blades
Mini, redondo, para micro hojas
mini, rond, pour micro-lames de bisturis
Mini, tondo, per micro lame



1/1

Blake
10-149-07-07

15,5 cm / 6 1/8"

abgewinkelt
angled
angulado
angle
angolato



1/1

10-160-01-07

13,5 cm / 5 3/8"

für Mikro-Skalpellklingen
for micro scalpel blades
para micro hojas
pour micro-lames de bisturis
per micro lame

Skalpellklingen

Scalpel Blades
 Hojas de bisturí
 Lames de bistouris
 Lame per bisturi



10-199-00-01

Skalpellklingen- ntferner
 Scalpel Blade Remover
 uita-hojas
 nl ve-lame
 Distributore lame

STERILE | R

einzel verpackt, V 100 Stück
 single packed, SU 100 pack
 envase individual, UV 100 piezas
 enveloppe individuelle, UC 100 untiés
 bustina individuale, UV 100 pezzi



1 1

steril	sterile	estéril	stérile	sterile
10-155-10-04	10-155-11-04	10-155-12-04	10-155-15-04	
Fig. 10	Fig. 11	Fig. 12	Fig. 15	

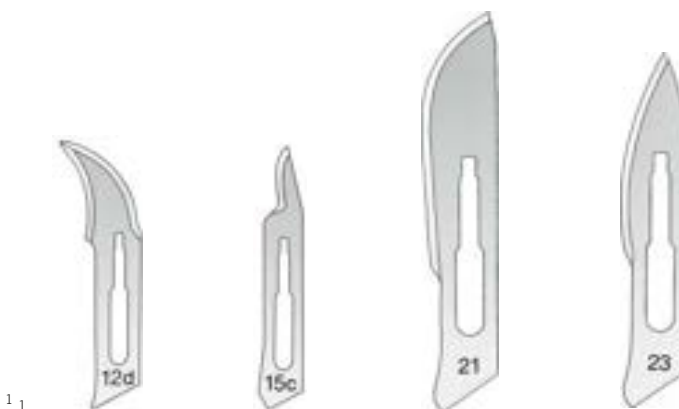

1 1

steril	sterile	estéril	stérile	sterile
10-156-12-04	10-156-15-04	10-155-21-04	10-155-23-04	
Fig. 12 D	Fig. 15 C	Fig. 21	Fig. 23	

Rasiermesser

Razor Knives

Navajas

Rasoirs

Rasoi

Skalpelle

Scalpels

Bisturís

Bistouris

Bisturi



10



1/2

Humby
10-878-00-07

32 cm / 12 5/8"

komplett mit Klinge
complete with blade
completo con hoja
complet avec lame
completo con lama

Humby
10-878-01-07

rsatzklinge
Spare Blade
Hoja de repuesto
Lame de rechange, seule
Lama di ricambio sola

➔ 10-878-00-07



1/2

Schink
10-880-00-07

30 cm / 11 5/8"

einstellbar von 0,1 bis 2,0 mm
adjustable from 0.1 to 2.0 mm
ajustable de 0,1 hasta 2,0 mm
réglable en épaisseur de 0,1 - 2,0 mm
regolabile da 1,0 a 2,0 mm

komplett mit 2 Spannplatten und einer Klinge
complete with 2 skin fixing plates and one blade
completo con 2 placas para extender la piel y una hoja
complet avec deux plaques pour tendre la peau et une lame
completo con 2 placche per stendere la pelle ed una lama

Schink
10-880-01-07

rsatzklinge
Spare Blade
Hoja de repuesto
Lame de rechange, seule
Lama di ricambio sola

➔ 10-880-00-07



1/2

Schink
10-880-02-07

Spannplatte
Skin Fixing Plate
Placa para extender la piel
Plaque pour tendre la peau
Placca per stendere la pelle

➔ 10-880-00-07



1/2

Silver
10-882-19-07

19,5 cm / 7 5/8"

Handdermatom
Dermatome
Dermatomo
Dermatome
Dermatomo a mano

Silver
10-882-90-98

rsatzklingen, Packung mit 10 Stück
Spare Blades, package with 10 units
Hojas de repuesto, paquete con 10 unidades
Lames de rechange, bo te de 10 lames
Lamette da ricambio, scatola di 10 lamette

➔ 10-882-19-07

Scheren
Scissors
Tijeras
Ciseaux
Forbici

11

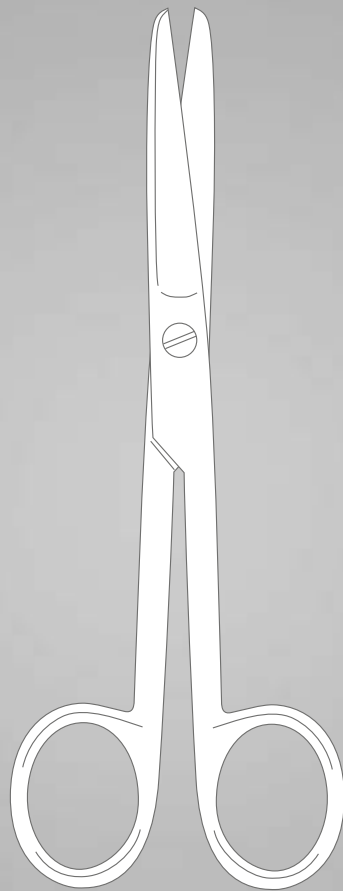

Scheren

Scissors

Tijeras

Ciseaux

Forbici



TC GOLD

TC-Hartmetall im Arbeitsende
Tungsten carbide in working end
Carburo de tungsteno en el extremo de trabajo
Carbure de tungstène sur extrémité de travail
Carburo di tungsteno nell'estremità operativa

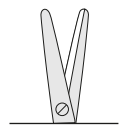

highMed

Scherenschliff Messerschliff
Scissor edge knife edge
Filo de tijeras filo de cuchillo
Aff taje ciseaux Aff taje couteau
Taglio forbici taglio coltello

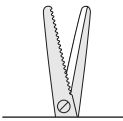

SuperCut

Wellenschliff Messerschliff
Serrated edge knife edge
Filo ondulado filo de cuchillo
Aff taje dentelé Aff taje couteau
Taglio ondulado taglio coltello

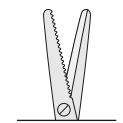

ST

Wellenschliff Scherenschliff
Serrated edge scissor edge
Filo ondulado filo de tijeras
Aff taje dentelé aff taje ciseaux
Taglio ondulado taglio forbici

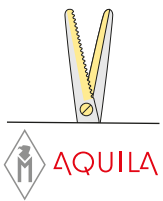

TC-Hartmetall mit Messerschliff Wellenschliff
 Tungsten carbide with knife edge serrated edge
 Carburo de tungsteno con filo de cuchillo filo ondulado
 Carbure de tungstène avec affûtage couteau affûtage dentelé
 Carburo di tungsteno con taglio coltello taglio ondulato

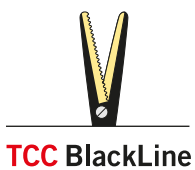

TC-Hartmetall mit Messerschliff Wellenschliff, Solid-Black-beschichtet
 Tungsten carbide with knife edge serrated edge, Solid Black coated
 Carburo de tungsteno con filo de cuchillo filo ondulado, recubrimiento Solid Black
 Carbure de tungstène avec affûtage couteau affûtage dentelé, revêtement Solid Black
 Carburo di tungsteno con taglio coltello taglio ondulato, rivestito in Solid Black

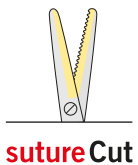

Nahtmaterialschere
 Suture material scissors
 Tijeras para material de sutura
 Ciseaux suture
 Forbici per materiale di sutura



Schlanke Modelle
 Slim models
 Modelos estilizados
 Modèles minces
 Modelli sottili

Chirurgische Scheren

Operating Scissors

Tijeras quirúrgicas

Ciseaux chirurgicaux

Forbici per chirurgia

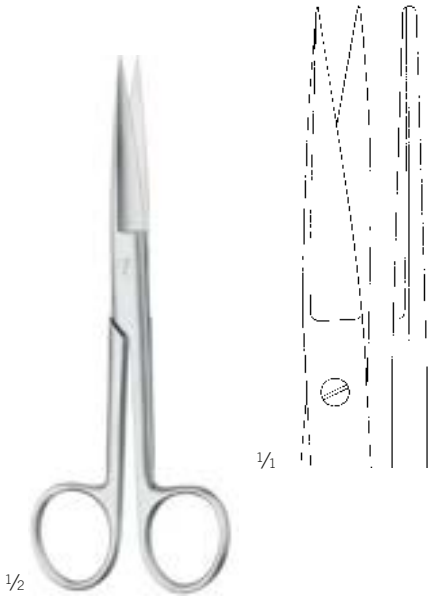

11-104-13-07
13 cm / 5 1/8"



11-109-14-07
14,5 cm / 5 7/8"



11-110-01-07 -
11-110-02-07
11 cm / 4 3/8"

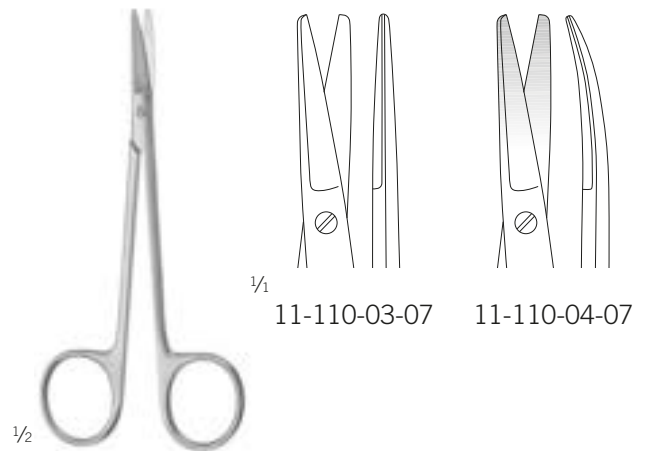
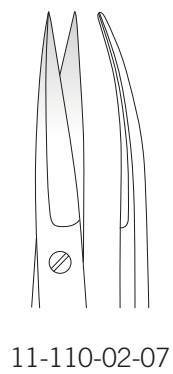

Knapp
11-110-03-07 -
11-110-04-07
12 cm / 4 7/8"

Präparierscheren

Dissecting Scissors
Tijeras de disección
Ciseaux dissection
Forbici per dissezione

Scheren

Scissors
Tijeras
Ciseaux
Forbici



Mayo	Standard	TC GOLD	SuperCut	ST	AQUILA
14 cm / 5 1/8"				28-408-14-07	28-466-14-07
14,5 cm / 5 7/8"	11-170-14-07	11-910-14-07	11-652-14-07		
17 cm / 6 5/8"	11-170-17-07	11-910-17-07	11-652-17-07	28-408-17-07	28-466-17-07
23 cm / 9"		11-910-23-07			
23,5 cm / 9 1/2"	11-170-23-07		11-652-23-07		

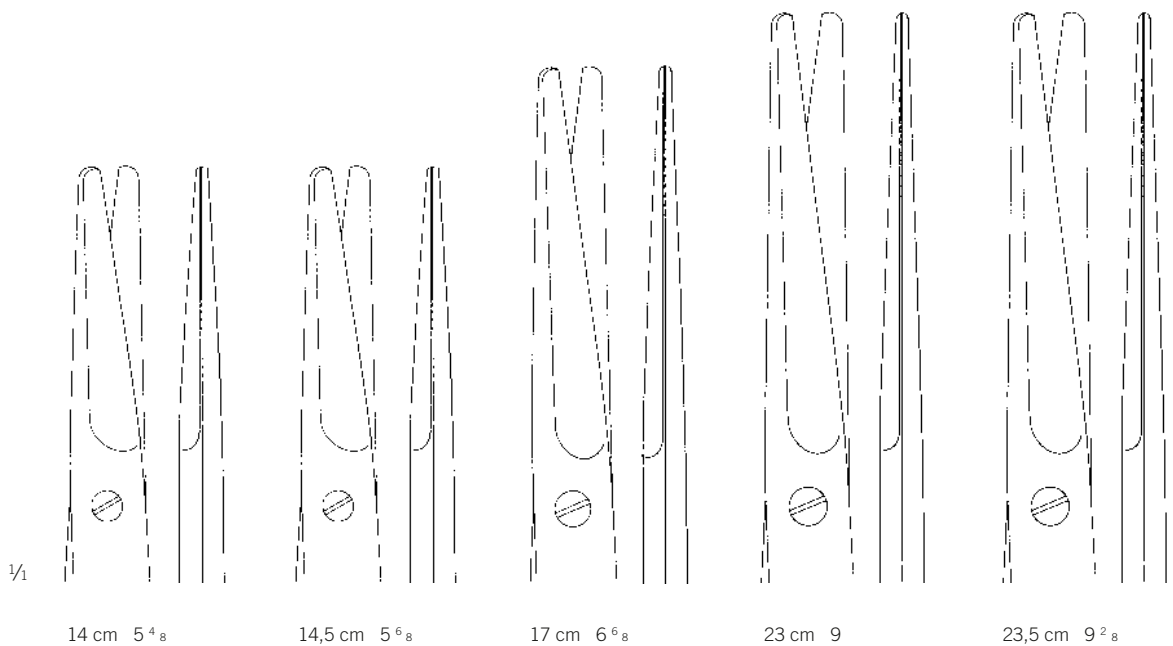

14 cm 5 1/8"

14,5 cm 5 7/8"

17 cm 6 5/8"

23 cm 9"

23,5 cm 9 1/2"

Präparierscheren

Dissecting Scissors
 Tijeras de disección
 Ciseaux dissection
 Forbici per dissezione



Mayo	Standard	TC GOLD	SuperCut	ST	AQUILA
14 cm / 5 4/8"				28-409-14-07	28-467-14-07
14,5 cm / 5 6/8"	11-171-14-07	11-911-14-07	11-653-14-07		
17 cm / 6 6/8"	11-171-17-07	11-911-17-07	11-653-17-07	28-409-17-07	28-467-17-07
23 cm / 9"		11-911-23-07			
23,5 cm / 9 2/8"	11-171-23-07		11-653-23-07		

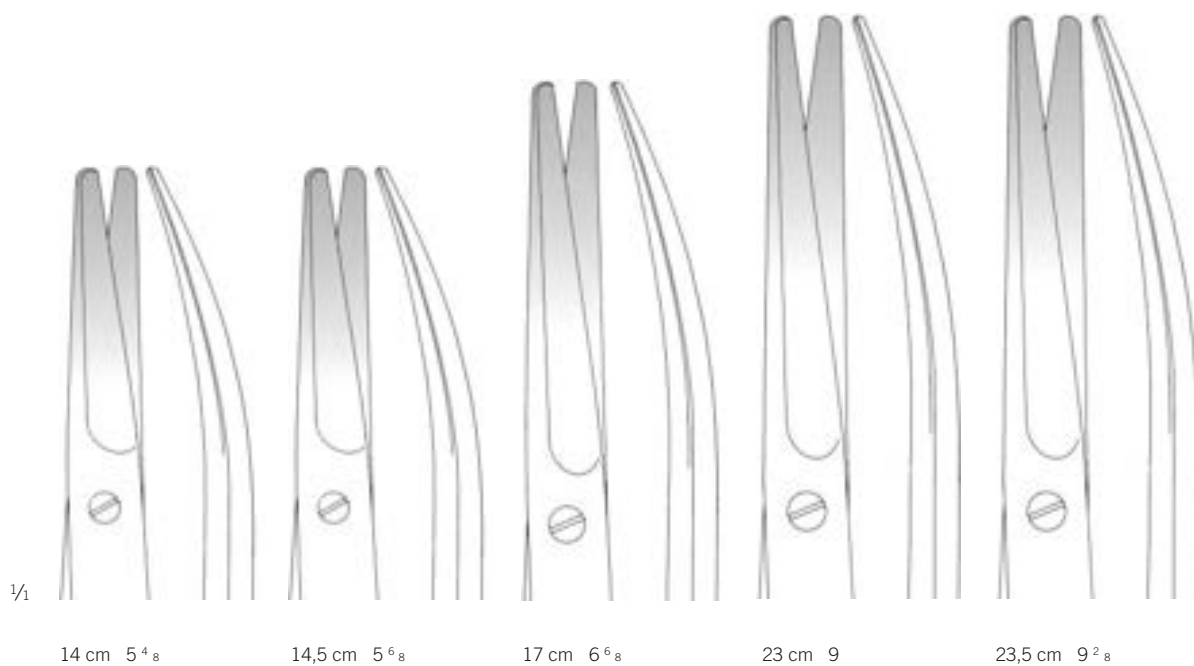

14 cm 5 4/8

14,5 cm 5 6/8

17 cm 6 6/8

23 cm 9

23,5 cm 9 2/8

Präparierscheren

Dissecting Scissors
Tijeras de disección
Ciseaux dissection
Forbici per dissezione

Scheren

Scissors
Tijeras
Ciseaux
Forbici



11



Mayo-Style	Standard	TC GOLD	SuperCut
15 cm 5 ⁷ / ₈	11-180-15-07	11-930-15-07	11-654-15-07
17 cm 6 ⁶ / ₈	11-180-17-07	11-930-17-07	11-654-17-07

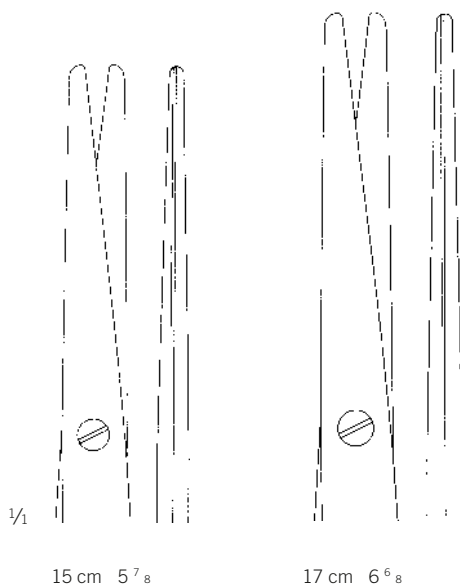

15 cm 5⁷/₈

17 cm 6⁶/₈

Präparierscheren

Dissecting Scissors
 Tijeras de disección
 Ciseaux dissection
 Forbici per dissezione



Mayo-Stille	Standard	TC GOLD	SuperCut	ST	AQUILA
14,5 cm / 5 7/8"		11-931-15-07			
15 cm / 5 7/8"	11-181-15-07		11-655-15-07	28-413-15-07	28-471-15-07
17 cm / 6 5/8"	11-181-17-07	11-931-17-07	11-655-17-07	28-413-17-07	28-471-17-07

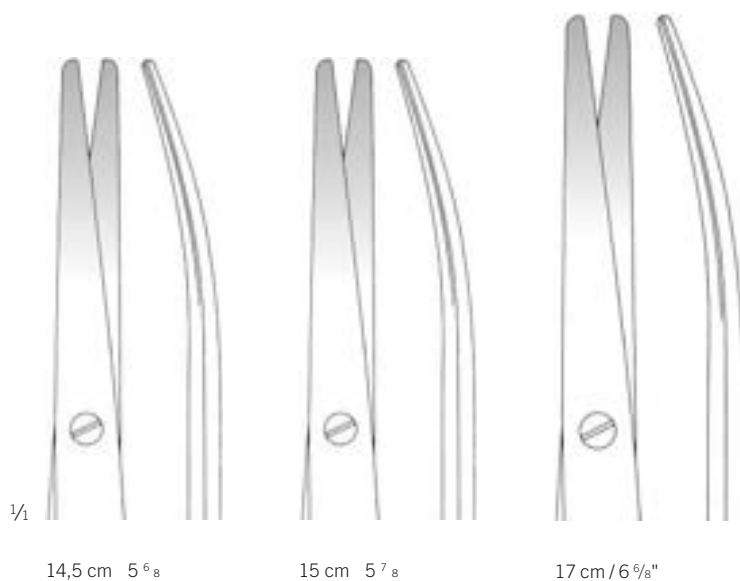

14,5 cm 5 6/8"

15 cm 5 7/8"

17 cm 6 5/8"

Chirurgische Scheren

Operating Scissors
Tijeras quirúrgicas
Ciseaux chirurgicaux
Forbici per chirurgia

Scheren

Scissors
Tijeras
Ciseaux
Forbici



Kelly	Standard	TC GOLD	SuperCut	ST	AQUILA
16 cm / 6 2/8"	11-226-16-07	11-992-16-07	11-656-16-07	28-434-16-07	28-474-16-07



16 cm / 6 2/8"

Chirurgische Scheren

Operating Scissors

Tijeras quirúrgicas

Ciseaux chirurgicaux

Forbici per chirurgia



Kelly	Standard	TC GOLD	SuperCut	ST	AQUILA
16 cm / 6 2/8"	11-227-16-07	11-993-16-07	11-657-16-07	28-435-16-07	28-475-16-07



16 cm / 6 2/8"

Präparierscheren

Dissecting Scissors
Tijeras de disección
Ciseaux dissection
Forbici per dissezione

Scheren

Scissors
Tijeras
Ciseaux
Forbici



11

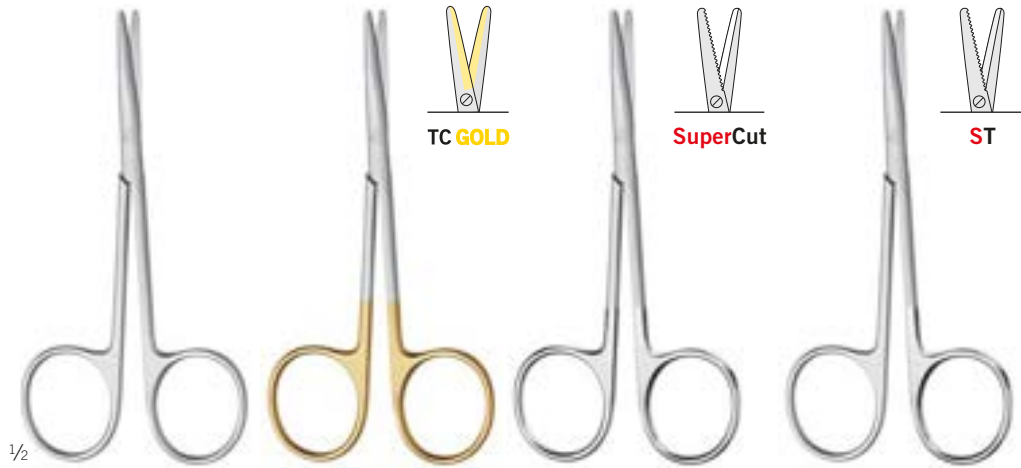

Metzenbaum	Standard	TC GOLD	SuperCut	ST
11,5 cm / 4 1/8"	11-248-11-07	11-936-11-07	11-658-11-07	28-424-11-07
14 cm / 5 1/8"				28-424-14-07
14,5 cm / 5 7/8"	11-250-14-07	11-938-14-07	11-658-14-07	

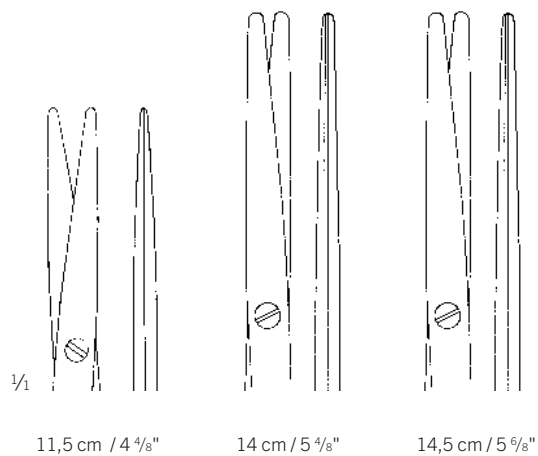

Präparierscheren

Dissecting Scissors

Tijeras de disección

Ciseaux dissection

Forbici per dissezione



Metzenbaum	Standard	TC GOLD	SuperCut	ST
11,5 cm / 4 5/8"	11-249-11-07	11-937-11-07	11-659-11-07	28-425-11-07
14 cm / 5 5/8"				28-425-14-07
14,5 cm / 5 6/8"	11-255-14-07	11-939-14-07	11-659-14-07	

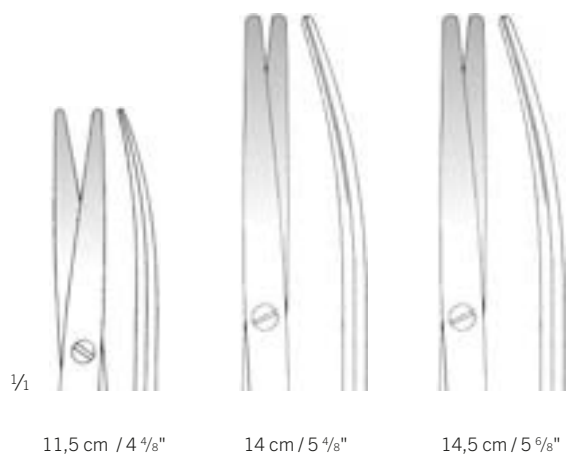

11,5 cm / 4 5/8"

14 cm / 5 5/8"

14,5 cm / 5 6/8"

Präparierscheren

Dissecting Scissors
Tijeras de disección
Ciseaux dissection
Forbici per dissezione

Scheren

Scissors
Tijeras
Ciseaux
Forbici



11



Metzenbaum	 AQUILA	TCCBlackLine
12 cm / 4 5/8"	11-887-11-07	11-917-11-07



12 cm / 4 5/8"

Präparierscheren

Dissecting Scissors
Tijeras de disección
Ciseaux dissection
Forbici per dissezione



1/2

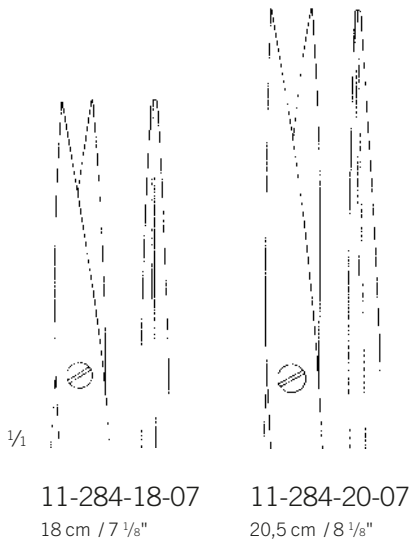

11-284-18-07
18 cm / 7 1/8"

11-284-20-07
20,5 cm / 8 1/8"

Metzenbaum-Nelson
11-284-18-07 -
11-284-20-07



1/2

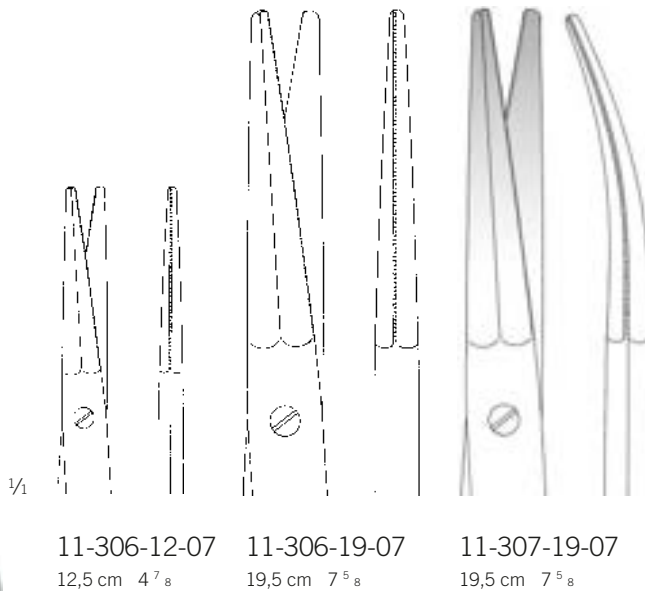

11-306-12-07
12,5 cm 4 7/8

11-306-19-07
19,5 cm 7 5/8

11-307-19-07
19,5 cm 7 5/8

Gorney
11-306-12-07 -
11-307-19-07

beide Schneiden gezahnt
both cutting edges serrated
ambos filos dentados
deux lames dentées
entrambe le lame dentate

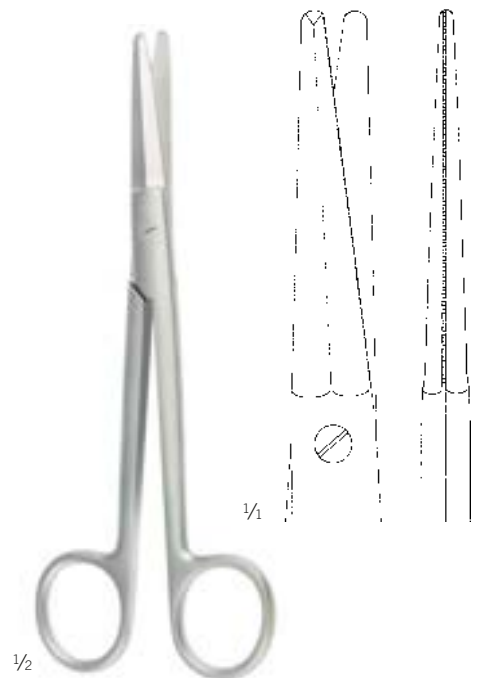

1/2

Aston
11-308-17-07
17 cm 6 6/8

eine Schneide gezahnt
one toothed cutting edge
una hoja dentada
une lame dentelée
una lama dentata

Präparierscheren

Dissecting Scissors
Tijeras de disección
Ciseaux dissection
Forbici per dissezione

Scheren

Scissors
Tijeras
Ciseaux
Forbici



11

Metzenbaum	Standard	TC GOLD	SuperCut	ST	AQUILA
18 cm / 7 1/8"	11-280-18-07	11-942-18-07	11-660-18-07	28-424-18-07	
20 cm / 7 7/8"					28-472-20-07
20,5 cm / 8 1/8"	11-280-20-07	11-942-20-07	11-660-20-07	28-424-20-07	
23 cm / 9"	11-280-23-07	11-942-23-07	11-660-23-07	28-426-23-07	28-472-23-07
26 cm / 10 2/8"	11-280-25-07	11-942-25-07	11-660-26-07	28-426-26-07	
28,5 cm / 11 2/8"	11-280-28-07	11-942-28-07	11-660-28-07		
31 cm / 12 2/8"	11-280-30-07	11-942-30-07	11-660-31-07	28-426-30-07	

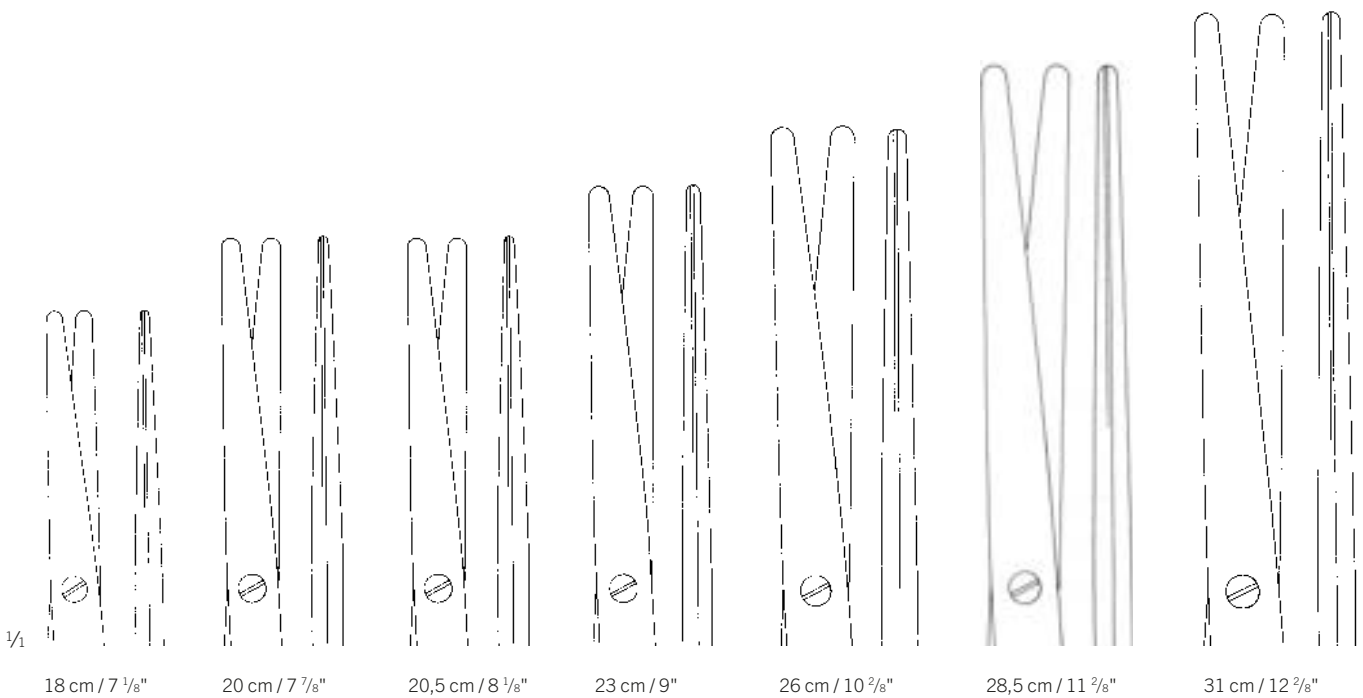

Präparierscheren

Dissecting Scissors
Tijeras de disección
Ciseaux dissection
Forbici per dissezione



Metzenbaum	Standard	TC GOLD	SuperCut	ST
18 cm / 7 1/8"	11-285-18-07	11-943-18-07	11-661-18-07	28-425-18-07
20 cm / 7 7/8"				28-425-20-07
20,5 cm / 8 1/8"	11-285-20-07	11-943-20-07	11-661-20-07	
23 cm / 9"	11-285-23-07	11-943-23-07	11-661-23-07	28-427-23-07
25 cm / 9 5/8"				
26 cm / 10 2/8"	11-285-25-07	11-943-25-07	11-661-26-07	28-427-26-07
28,5 cm / 11 2/8"	11-285-28-07	11-943-28-07	11-661-28-07	
30 cm / 11 5/8"		11-943-30-07		28-427-30-07
31 cm / 12 2/8"	11-285-30-07		11-661-31-07	

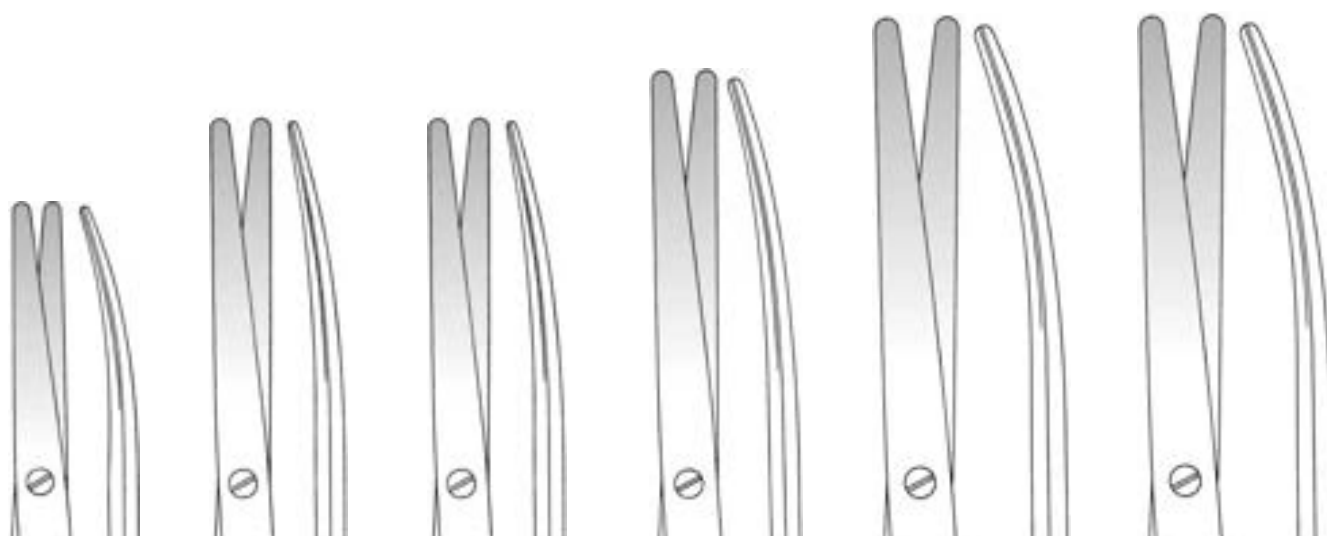

18 cm / 7 1/8"

20 cm / 7 7/8"

20,5 cm / 8 1/8"

23 cm / 9"

25 cm / 9 5/8"

26 cm / 10 2/8"

Präparierscheren

Dissecting Scissors
Tijeras de disección
Ciseaux dissection
Forbici per dissezione

Scheren

Scissors
Tijeras
Ciseaux
Forbici



11

Metzenbaum	 AQUILA	TCCBlackLine
18 cm / 7 1/8"	11-887-18-07	11-917-18-07
20 cm / 7 7/8"		
20,5 cm / 8 1/8"	11-887-20-07	11-917-20-07
23 cm / 9"	11-887-23-07	11-917-23-07
25 cm / 9 5/8"	11-887-25-07	11-917-25-07
26 cm / 10 2/8"		
28,5 cm / 11 2/8"		
30 cm / 11 5/8"	11-887-30-07	11-917-30-07
31 cm / 12 2/8"		

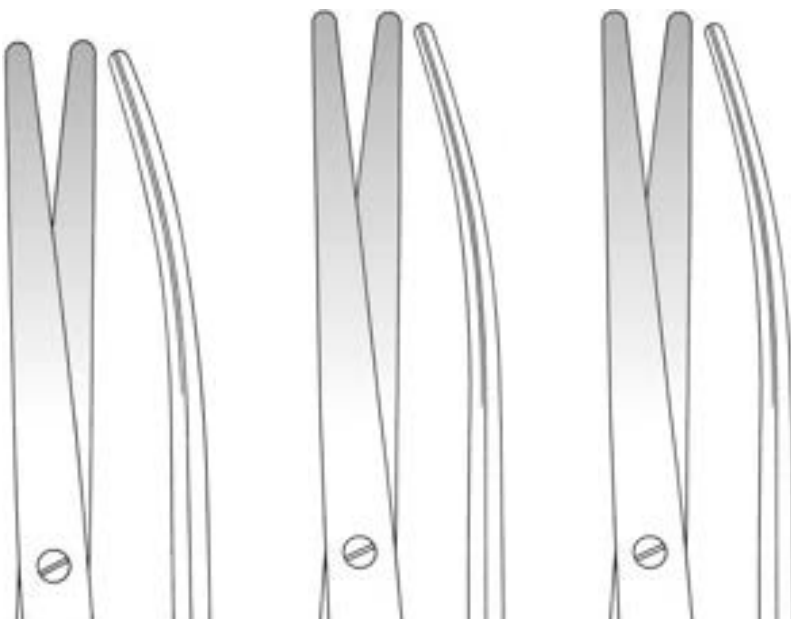

28,5 cm / 11 2/8"

30 cm / 11 5/8"

31 cm / 12 1/8"

Präparierscheren

Dissecting Scissors

Tijeras de disección

Ciseaux dissection

Forbici per dissezione



Lexer	Standard	TC GOLD	SuperCut	ST	AQUILA
16 cm / 6 2/8"	11-310-16-07	11-950-16-07	11-662-16-07	28-410-16-07	28-468-16-07
21 cm / 8 2/8"		11-950-21-07			

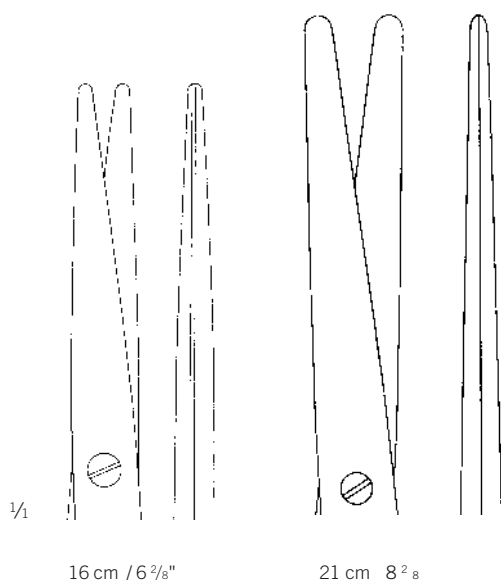

Präparierscheren

Dissecting Scissors
Tijeras de disección
Ciseaux dissection
Forbici per dissezione

Scheren

Scissors
Tijeras
Ciseaux
Forbici



Lexer	Standard	TC GOLD	SuperCut	ST	AQUILA
16 cm / 6 2/8"	11-311-16-07	11-951-16-07	11-663-16-07	28-411-16-07	28-469-16-07
21 cm / 6 2/8"		11-951-21-07			

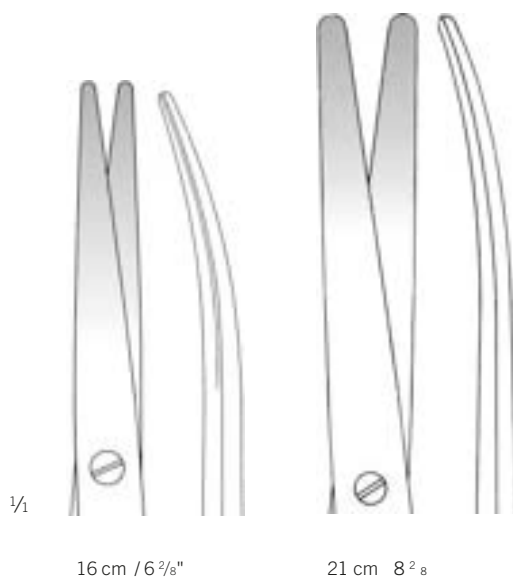

16 cm / 6 2/8"

21 cm 8 2/8"

Präparierscheren

Dissecting Scissors
Tijeras de disección
Ciseaux dissection
Forbici per dissezione



Lexer	 AQUILA	TCCBlackLine
16 cm / 6 2/8"	11-895-16-07	11-923-16-07



Präparierscheren

Dissecting Scissors
Tijeras de disección
Ciseaux dissection
Forbici per dissezione

Scheren

Scissors
Tijeras
Ciseaux
Forbici



Cinelli
11-317-11-07
11,5 cm / 4 ⁷/₈"



Fomon
11-317-14-07
14 cm / 5 ⁴/₈"

Präparierscheren

Dissecting Scissors
 Tijeras de disección
 Ciseaux dissection
 Forbici per dissezione



Lexer-Baby	Standard	SuperCut
10 cm / 3 7/8"	11-320-10-07	11-662-10-07

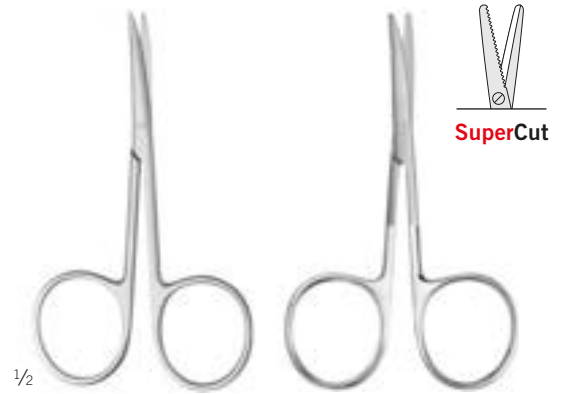

Standard	SuperCut
11-321-10-07	11-663-10-07



Feine Präparierscheren

Delicate Dissecting Scissors

Tijeras finas de disección

Ciseaux fins dissection

Forbici fini per dissezione

Scheren

Scissors

Tijeras

Ciseaux

Forbici



finoLine



11

Metzenbaum	Standard	TC GOLD	ST
14 cm / 5 4/8"			28-428-14-07
14,5 cm / 5 9/8"	11-326-14-07	11-954-14-07	
18 cm / 7 1/8"	11-330-18-07	11-960-18-07	28-428-18-07
20 cm / 7 7/8"			28-428-20-07
20,5 cm / 8 1/8"	11-330-20-07		
23 cm / 9"	11-330-23-07		28-428-23-07

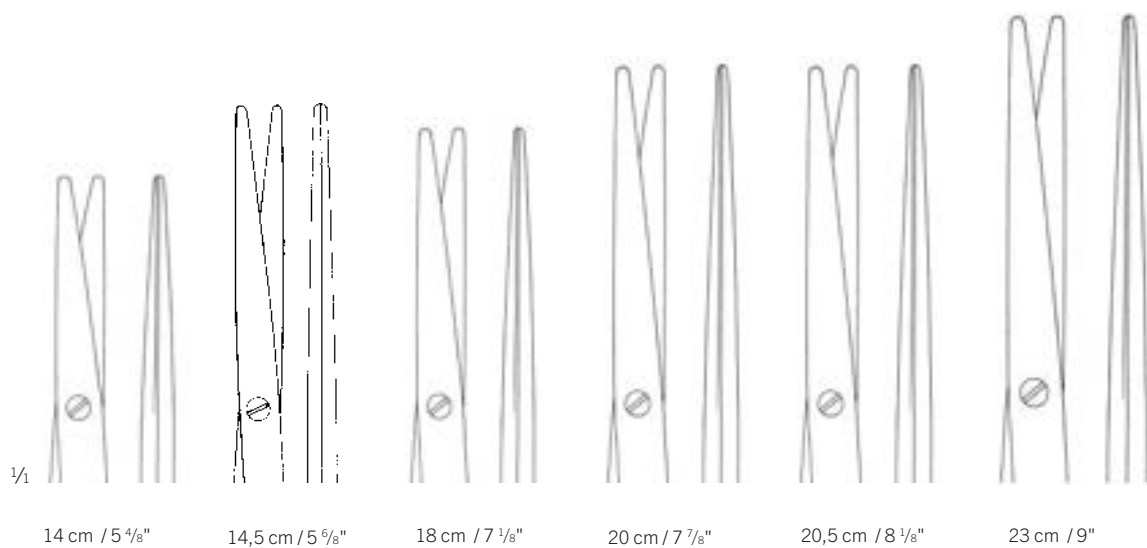

Feine Präparierscheren

Delicate Dissecting Scissors

Tijeras finas de disección

Ciseaux fins dissection

Forbici fini per dissezione

finoLine



Metzenbaum-Fino	Standard	TCGOLD	SuperCut
14 cm / 5 4/8"			
14,5 cm / 5 5/8"	11-327-14-07	11-955-14-07	11-665-14-07
18 cm / 7 1/8"	11-331-18-07	11-961-18-07	11-665-18-07
20 cm / 7 7/8"			
20,5 cm / 8 1/8"	11-331-20-07	11-961-20-07	11-665-20-07
23 cm / 9"	11-331-23-07	11-961-23-07	11-665-23-07
26 cm / 10 2/8"		11-961-25-07	
28,5 cm / 11 2/8"		11-961-28-07	

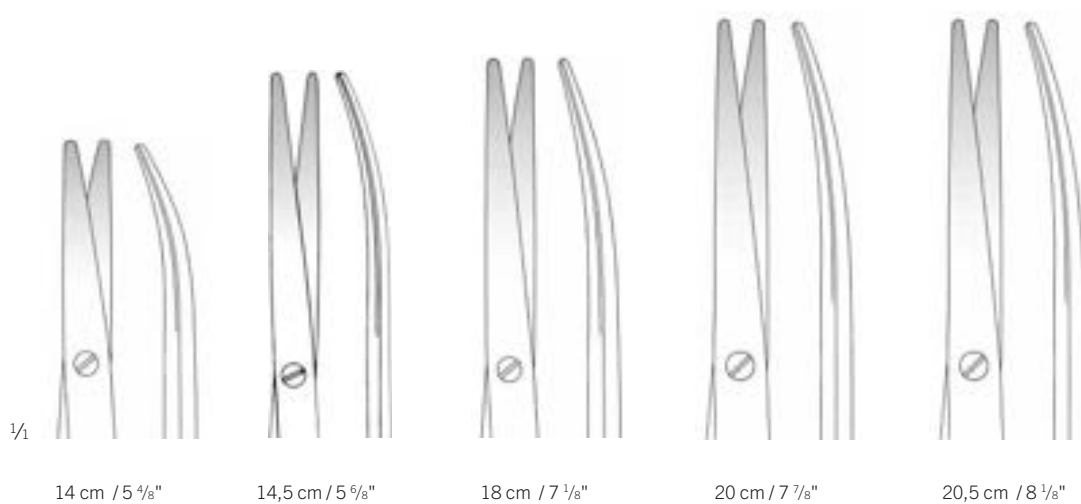

Feine Präparierscheren

Delicate Dissecting Scissors

Tijeras finas de disección

Ciseaux fins dissection

Forbici fini per dissezione

Scheren

Scissors

Tijeras

Ciseaux

Forbici



finoLine



Metzenbaum-Fino	ST	AQUILA
14 cm / 5 4/8"	28-429-14-07	
14,5 cm / 5 7/8"		11-889-14-07
18 cm / 7 1/8"	28-429-18-07	11-889-18-07
20 cm / 7 7/8"	28-429-20-07	
20,5 cm / 8 1/8"		
23 cm / 9"	28-429-23-07	
26 cm / 10 2/8"	28-429-26-07	
28,5 cm / 11 2/8"	28-429-28-07	

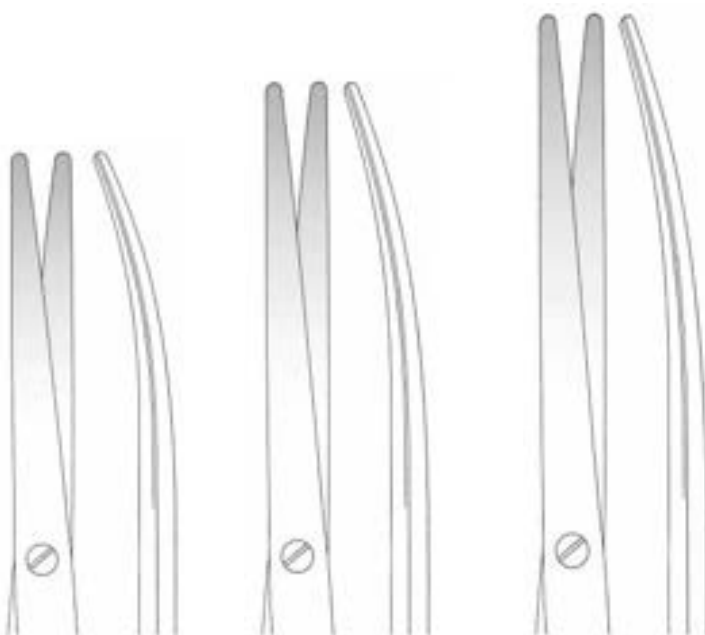

23 cm / 9"

26 cm / 10 2/8"

28,5 cm / 11 2/8"

Feine Präparierscheren

Delicate Dissecting Scissors

Tijeras finas de disección

Ciseaux fins dissection

Forbici fini per dissezione

finoLine



Metzenbaum-Fino	Standard	TC GOLD	ST
14 cm / 5 5/8"			28-422-14-07
14,5 cm / 5 9/8"	11-328-14-07	11-956-14-07	
18 cm / 7 1/8"		11-962-18-07	
20 cm / 7 7/8"		11-962-20-07	
23 cm / 9"		11-962-23-07	

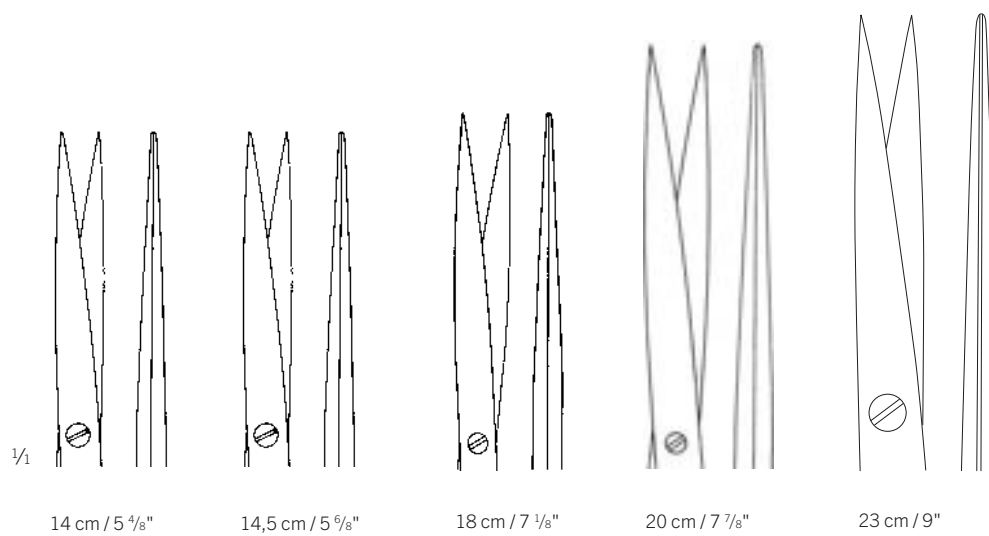

14 cm / 5 5/8"

14,5 cm / 5 9/8"

18 cm / 7 1/8"

20 cm / 7 7/8"

23 cm / 9"

Feine Präparierscheren

Delicate Dissecting Scissors

Tijeras finas de disección

Ciseaux fins dissection

Forbici fini per dissezione

Scheren

Scissors

Tijeras

Ciseaux

Forbici



finoLine



Metzenbaum-Fino	Standard	TC GOLD	ST
14 cm / 5 4/8"			28-423-14-07
14,5 cm / 5 6/8"	11-329-14-07	11-957-14-07	
18 cm / 7 1/8"	11-329-18-07		28-423-18-07
20 cm / 7 7/8"	11-329-20-07		

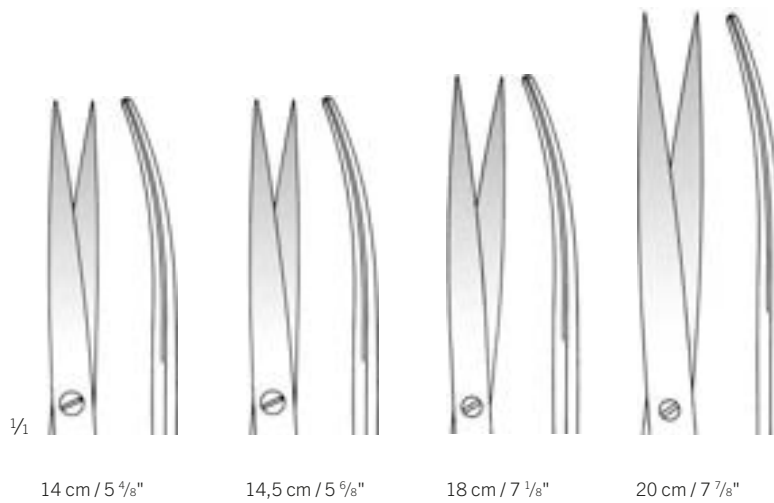

Feine Präparierscheren

Delicate Dissecting Scissors

Tijeras finas de disección

Ciseaux fins dissection

Forbici fini per dissezione

finoLine



Metzenbaum-Fino	Standard	TC GOLD	ST	AQUILA
18 cm / 7 1/8"	11-335-18-07	11-967-18-07	28-431-18-07	28-473-18-07
20 cm / 7 7/8"			28-431-20-07	28-473-20-07
20,5 cm / 8 1/8"	11-335-20-07	11-967-20-07		
23 cm / 9"	11-335-23-07	11-967-23-07	28-431-23-07	28-473-23-07

schlankes Modell, S-Form
slender pattern, S-shaped
modelo delgado, forma S
mod le gracile, courbé en S
modello delicato, curvo in forma S

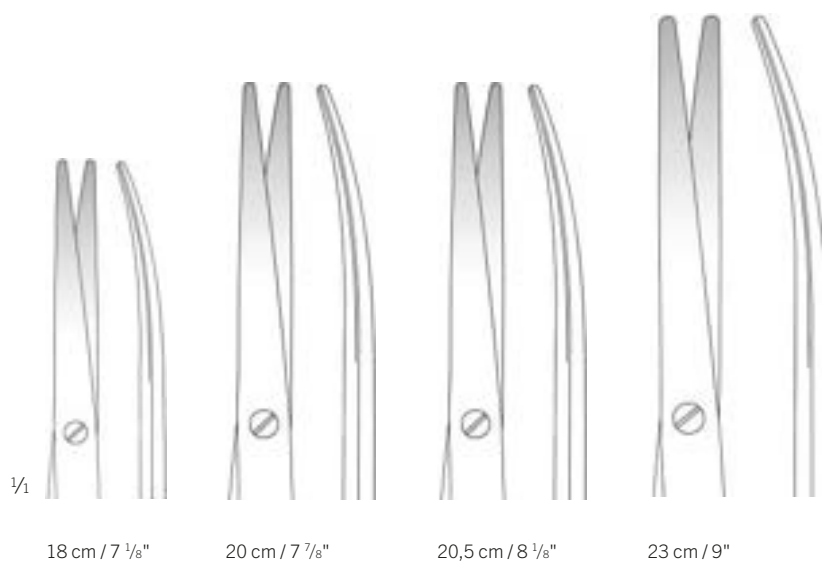

18 cm / 7 1/8"

20 cm / 7 7/8"

20,5 cm / 8 1/8"

23 cm / 9"

Feine Präparierscheren

Delicate Dissecting Scissors

Tijeras finas de disección

Ciseaux fins dissection

Forbici fini per dissezione

Scheren

Scissors

Tijeras

Ciseaux

Forbici



finoLine

11



11-344-11-07



11-345-11-07

11-344-11-07 -
11-345-11-07

11 cm / 4 3/8"

Chirurgische Scheren

Operating Scissors

Tijeras quirúrgicas

Ciseaux chirurgicaux

Forbici per chirurgia



Joseph	Standard	TC GOLD	SuperCut	ST
14,5 cm / 5 7/8"	11-350-14-07	11-948-14-07	11-666-14-07	
15 cm / 5 7/8"				28-432-15-07

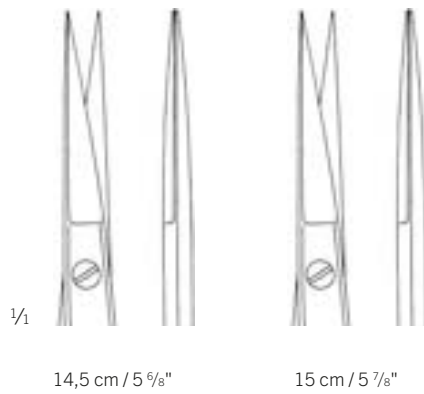

14,5 cm / 5 7/8"

15 cm / 5 7/8"

Chirurgische Scheren

Operating Scissors
Tijeras quirúrgicas
Ciseaux chirurgicaux
Forbici per chirurgia

Scheren

Scissors
Tijeras
Ciseaux
Forbici



11



Joseph	Standard	TC GOLD	SuperCut	ST
14,5 cm / 5 7/8"	11-351-14-07	11-949-14-07	11-667-14-07	
15 cm / 5 7/8"				28-433-15-07

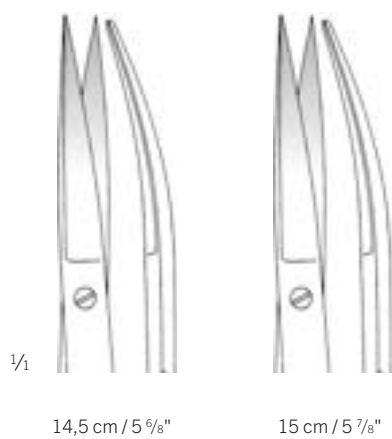

Face-lift-Scheren, Präparierscheren

Face-lift Scissors, Dissecting Scissors

Tijeras para Face-lift, Tijeras de disección

Ciseaux pour Face-lift, Ciseaux dissection

Forbici per Face-lift, Forbici per dissezione

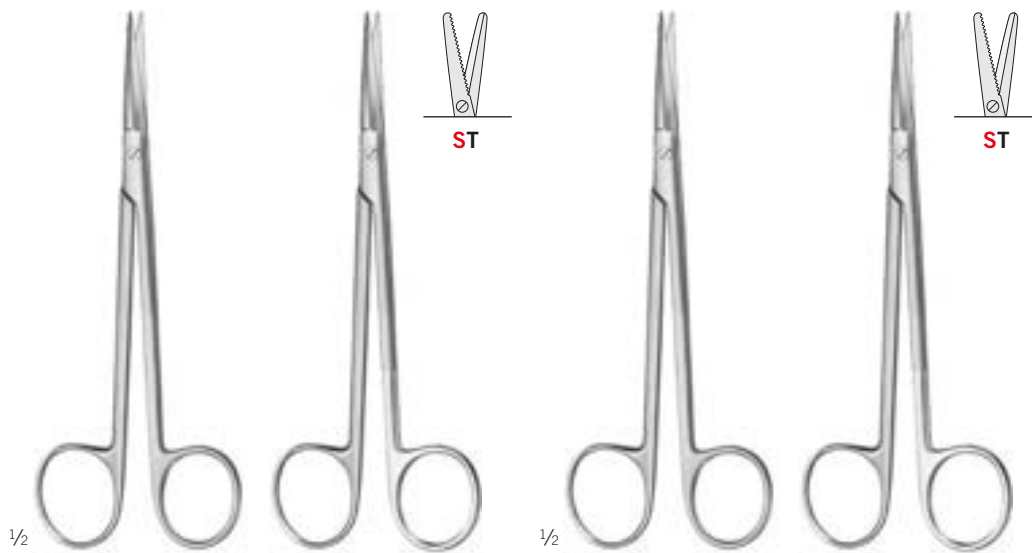

Peck-Joseph	Standard	ST
14 cm / 5 4/8"		28-418-14-07
14,5 cm / 5 6/8"	11-352-14-07	

Standard	ST
	28-419-14-07
11-353-14-07	

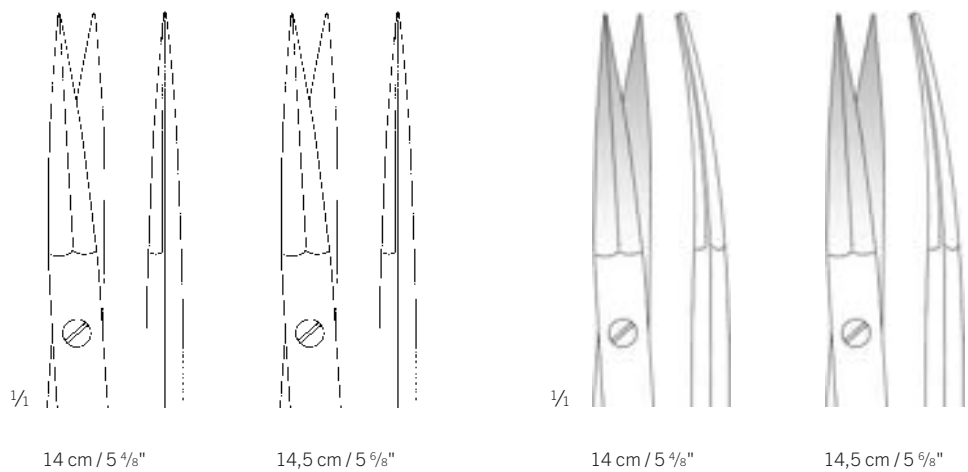

Face-lift-Scheren, Präparierscheren

Face-lift Scissors, Dissecting Scissors

Tijeras para Face-lift, Tijeras de disección

Ciseaux pour Face-lift, Ciseaux dissection

Forbici per Face-lift, Forbici per dissezione

Scheren

Scissors

Tijeras

Ciseaux

Forbici



	Standard	ST
14 cm / 5 4/8"		28-420-14-07
14,5 cm / 5 6/8"	11-354-14-07	

	Standard	ST
		28-421-14-07
	11-355-14-07	

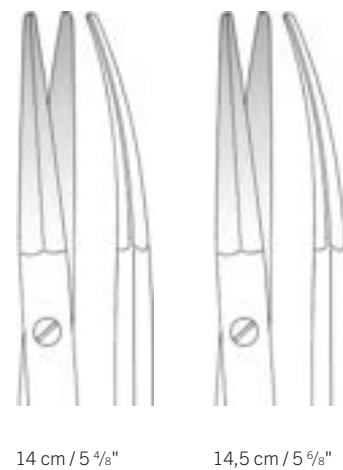
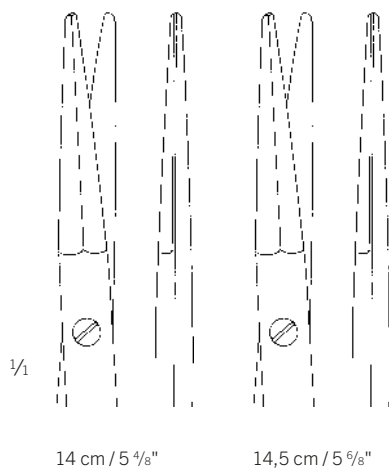

Dissektions- u. Zahnfleischschere

Dissecting Scissors
Tijera de disección
Ciseaux dissection
Forbici per dissezione



11-358-13-07

13 cm / 5 1/8"

Dissektions- u. Zahnfleischschere
Dissecting Scissors
Tijera de disección
Ciseaux à dissection
Forbici per dissezione

Face-lift-Scheren, Präparierscheren

Face-lift Scissors, Dissecting Scissors

Tijeras para Face-lift, Tijeras de disección

Ciseaux pour Face-lift, Ciseaux dissection

Forbici per Face-lift, Forbici per dissezione

Scheren

Scissors

Tijeras

Ciseaux

Forbici



Kilner	Standard	SuperCut
12 cm / 4 5/8"	11-359-12-07	11-669-12-07
15 cm / 5 7/8"	11-359-15-07	11-669-15-07
18 cm / 7 1/8"	11-359-18-07	11-670-18-07
20 cm / 7 7/8"	11-359-20-07	

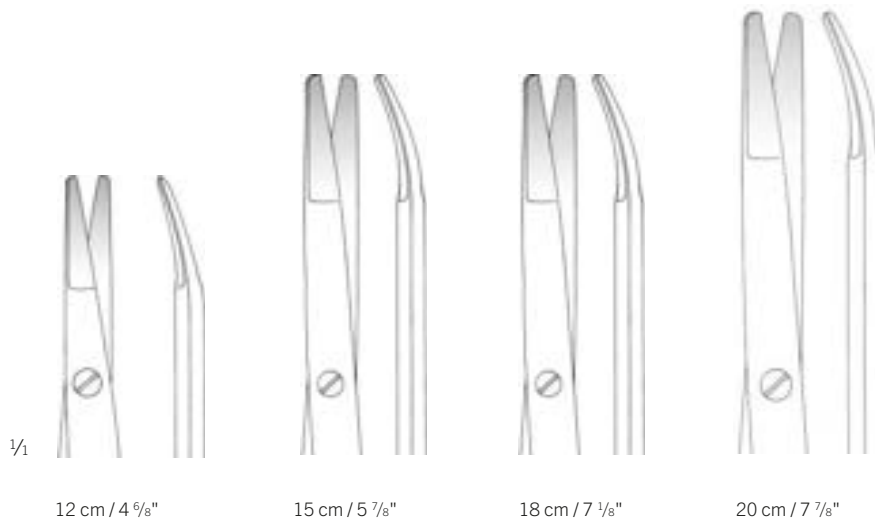

12 cm / 4 5/8"

15 cm / 5 7/8"

18 cm / 7 1/8"

20 cm / 7 7/8"

Präparierscheren, Gefäßscheren

Dissecting Scissors, Vascular Scissors

Tijeras de disección, Tijeras vasculares

Ciseaux dissection, Ciseaux vasculaires

Forbici per dissezione, Forbici vascolari



Reynolds	Standard
14 cm / 5 4/8"	11-364-14-07
15,5 cm / 6 1/8"	11-364-15-07
18 cm / 7 1/8"	11-364-18-07



14 cm / 5 4/8"



15,5 cm / 6 1/8"



18 cm / 7 1/8"

Präparierscheren, Gefäßscheren

Dissecting Scissors, Vascular Scissors
 Tijeras de disección, Tijeras vasculares
 Ciseaux dissection, Ciseaux vasculaires
 Forbici per dissezione, Forbici vascolari

Scheren

Scissors
 Tijeras
 Ciseaux
 Forbici



11

Reynolds	Standard	SuperCut
14 cm / 5 1/8"	11-365-14-07	
15,5 cm / 6 1/8"	11-365-15-07	11-671-15-07
18 cm / 7 1/8"	11-365-18-07	11-671-18-07

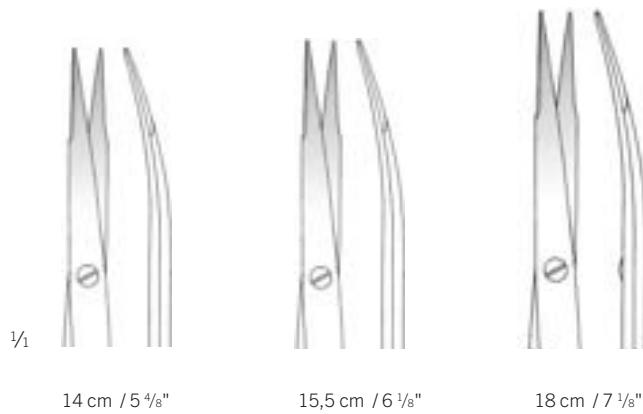

Kurze Mikro-Scheren

Short Micro Scissors

Micro-Tijeras, corto

Micro-Ciseaux, court

Micro-Forbici, corto



1/2

11-370-01-07 -
11-371-04-07

12 cm / 4 6/8"



	●	A spitz/spitz sharp/sharp agudo/agudo pointu/pointu appuntato/appuntato	A spitz/spitz sharp/sharp agudo/agudo pointu/pointu appuntato/appuntato	spitz/stumpf sharp/blunt agudo/romo pointu/mousse appuntato/smusso	D stumpf/stumpf blunt/blunt romo/romo mousse/mousse smusso/smusso	mit Knopf with button con botón avec bouton con bottone
	U	7 mm	7 mm	7 mm	7 mm	7 mm
	St	11-370-01-07	11-371-01-07	11-371-02-07	11-371-03-07	11-371-04-07



1/2

11-370-02-07 -
11-371-08-07

12 cm / 4 6/8"



	●	A spitz/spitz sharp/sharp agudo/agudo pointu/pointu appuntato/appuntato	A spitz/spitz sharp/sharp agudo/agudo pointu/pointu appuntato/appuntato	spitz/stumpf sharp/blunt agudo/romo pointu/mousse appuntato/smusso	D stumpf/stumpf blunt/blunt romo/romo mousse/mousse smusso/smusso	mit Knopf with button con botón avec bouton con bottone
	U	7 mm	7 mm	7 mm	7 mm	7 mm
	St	11-370-02-07	11-371-05-07	11-371-06-07	11-371-07-07	11-371-08-07

A Adventitia
D Pr paration
A-SB Adventitia, ein gezahntes Blatt
D-SB Pr paration, ein gezahntes Blatt

A Adventitia
D Dissection
A-SB Adventitia, one serrated blade
D-SB Dissection, one serrated blade

A Adventicia
D Disección
A-SB Adventicia, una hoja dentada
D-SB Disección, una hoja dentada

A Advantice
D Dissection
A-SB Advantice, une lame dentelée
D-SB Dissection, une lame dentelée

A Aventizia
D Dissezione
A-SB Aventizia, una lama dentata
D-SB Dissezione, una lama dentata

Feine Präparierscheren

Delicate Dissecting Scissors
 Tijeras finas de disección
 Ciseaux fins dissection
 Forbici fini per dissezione

Scheren

Scissors
 Tijeras
 Ciseaux
 Forbici



finoLine



Toennis-Adson	Standard	TC GOLD	AQUILA	TCC BlackLine	ST
17 cm / 6 5/8"				11-921-17-07	
17,5 cm / 6 7/8"	11-459-17-07	11-965-17-07	11-893-17-07		
18 cm / 7 1/8"			28-477-18-07		28-437-18-07

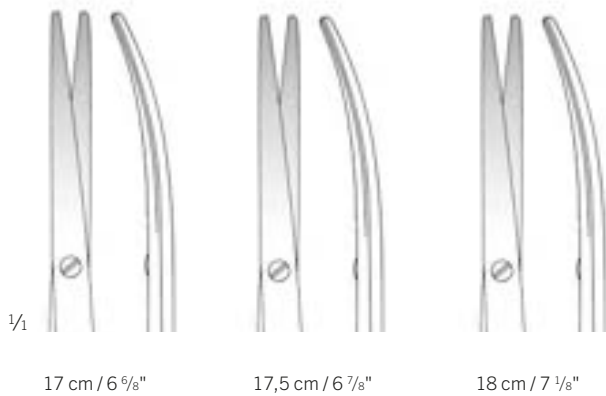

17 cm / 6 5/8"

17,5 cm / 6 7/8"

18 cm / 7 1/8"

Tonsillenscheren, Präparierscheren

Tonsil Scissors, Dissecting Scissor

Tijeras para amígdalas, Tijeras de disección

Ciseaux pour les amygdales, Ciseaux dissection

Forbici per tonsille, Forbici per dissezione

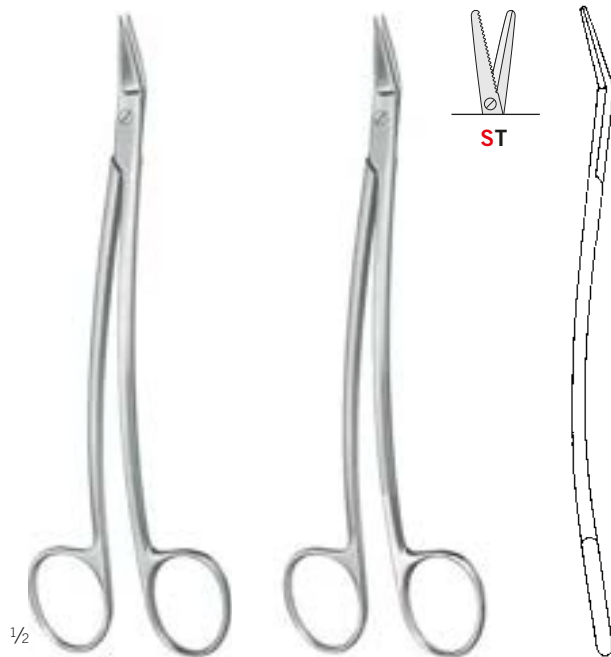

Dean	Standard	ST
17 cm / 6 5/8"		28-463-17-07
17,5 cm / 6 7/8"	11-495-17-07	

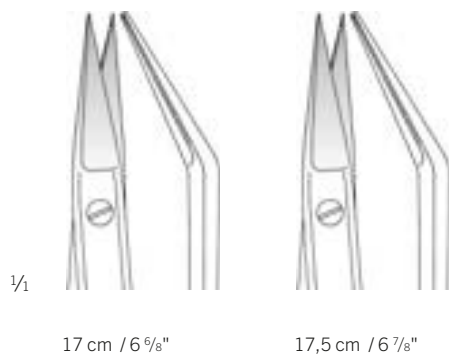

Nasenscheren

Nasal Scissors
Tijeras nasales
Ciseaux nasaux
Forbici nasali

Scheren

Scissors
Tijeras
Ciseaux
Forbici



11

Fomon	Standard	ST	AQUILA
	40°	40°	40°
13 cm / 5 1/8"		28-459-13-07	28-481-13-07
14 cm / 6 2/8"	11-507-15-07		

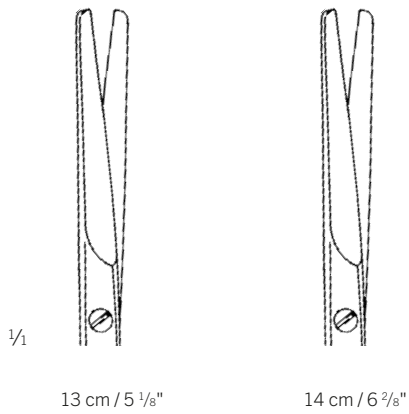

Nasenscheren

Nasal Scissors

Tijeras nasales

Ciseaux nasaux

Forbici nasali

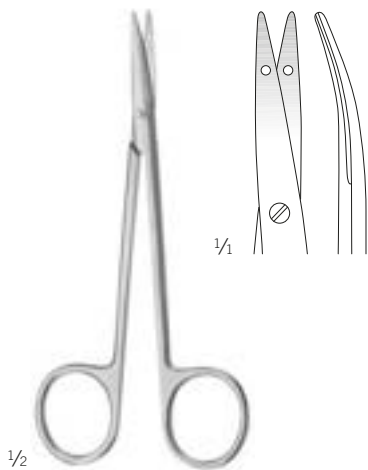

Littler
11-508-12-07

12 cm / 4 5/8"

Fadenschere
Stitch scissors
Tijeras para hilos
Ciseaux à ligatures
Forbici per legature



Cottle
11-509-10-07 -
11-511-10-07

10 cm / 5 1/8"

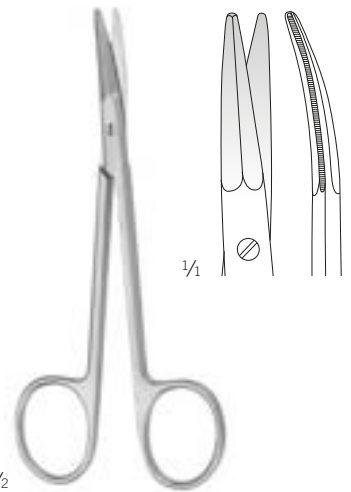
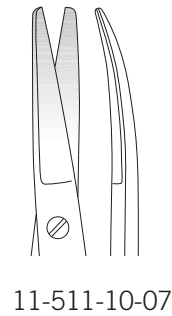

Fomon
11-509-13-07

12,5 cm / 4 7/8"

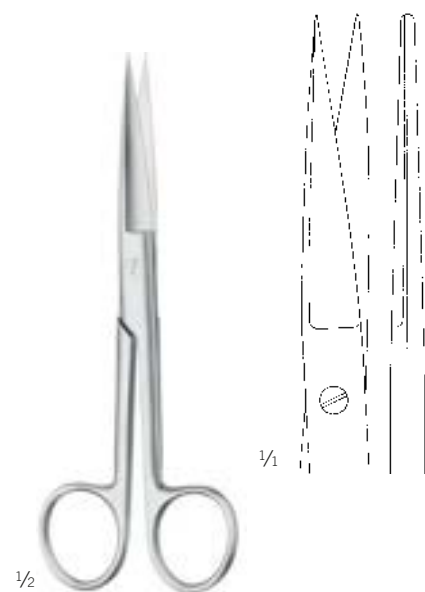

Convers
11-509-14-07

13,5 cm / 5 3/8"

Nasenscheren

Nasal Scissors
Tijeras nasales
Ciseaux nasaux
Forbici nasali

Scheren

Scissors
Tijeras
Ciseaux
Forbici

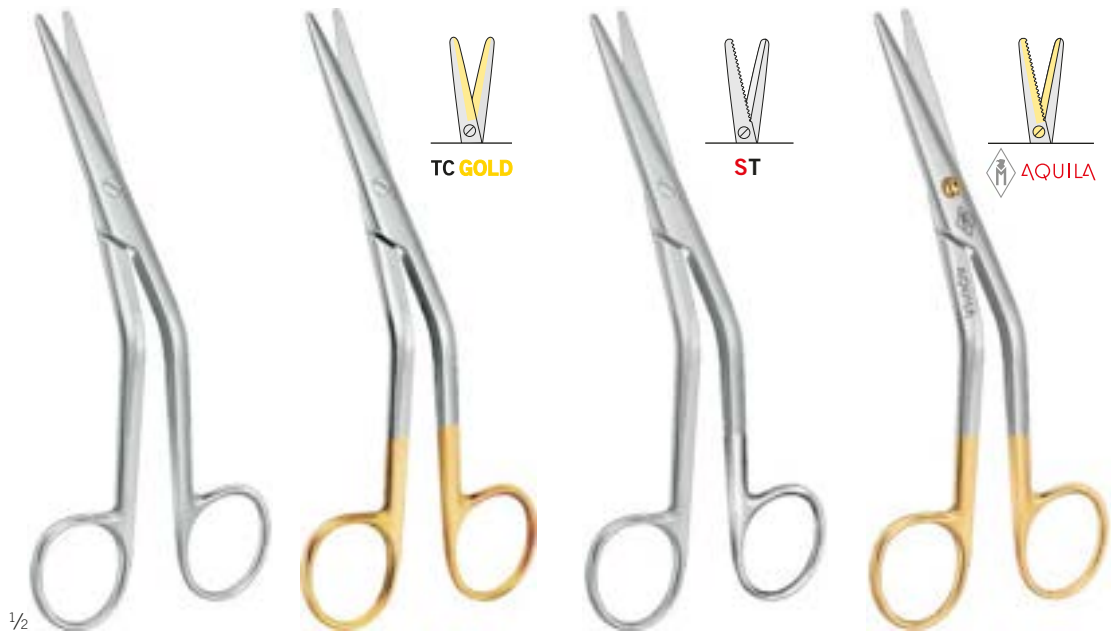

11

Cottle	Standard	TCGOLD	ST	AQUILA
	40°	40°	40°	40°
15,5 cm / 6 1/8"	11-509-16-07			
16 cm / 6 2/8"		11-505-16-07	28-461-16-07	28-479-16-07

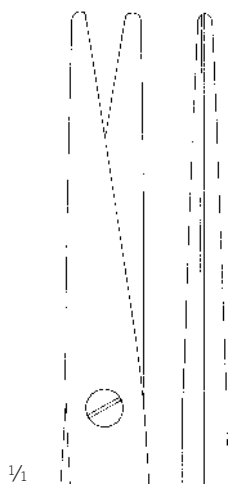

15,5 cm / 6 1/8"

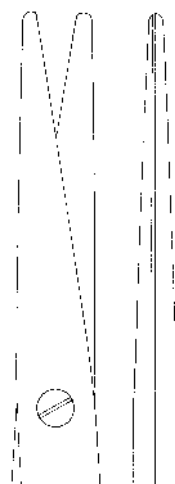

16 cm / 6 2/8"

Nasenscheren

Nasal Scissors

Tijeras nasales

Ciseaux nasaux

Forbici nasali



Heymann	Standard	ST
	40°	40°
18 cm / 7 1/8"	11-511-18-07	28-453-18-07



Nasenscheren

Nasal Scissors
Tijeras nasales
Ciseaux nasaux
Forbici nasali

Scheren

Scissors
Tijeras
Ciseaux
Forbici



11



1/2

Heymann	Standard	Standard
	40°	40°
18 cm / 7 1/8"	11-513-18-07	
20 cm / 7 7/8"		11-510-20-07

eine Schneide gezahnt
one toothed cutting edge
una hoja dentada
une lame dentelée
una lama dentata



1/1

18 cm / 7 1/8"

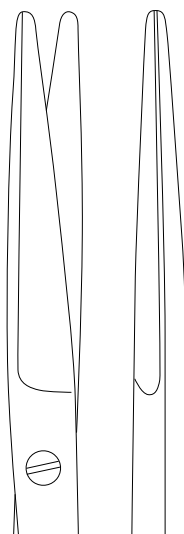

20 cm / 7 7/8"

Nasenscheren

Nasal Scissors

Tijeras nasales

Ciseaux nasaux

Forbici nasali

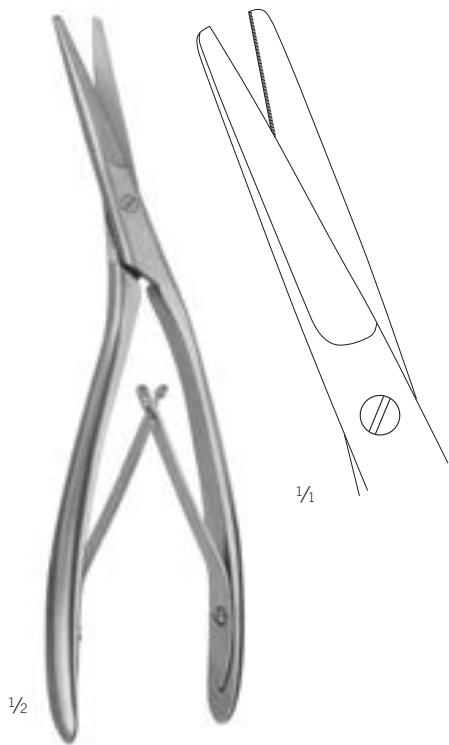

Cottle
11-509-18-07
18 cm / 7 1/8"

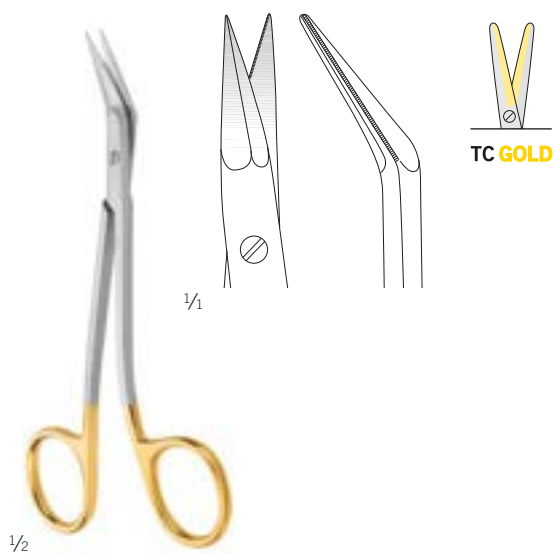

Giunta
11-513-13-07
13,5 cm / 5 3/8"

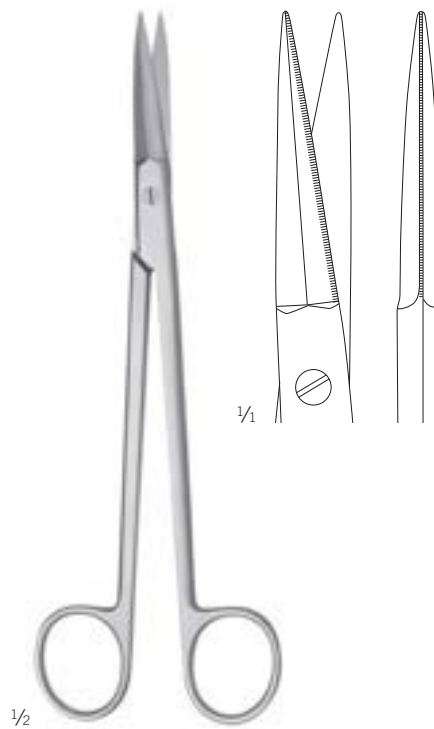

McIndoe
11-514-19-07
19 cm / 7 4/8"

Nasenscheren

Nasal Scissors
Tijeras nasales
Ciseaux nasaux
Forbici nasali

Scheren

Scissors
Tijeras
Ciseaux
Forbici



11



Aufricht	Standard	ST
14 cm / 5 4/8"	11-513-14-07	28-455-14-07

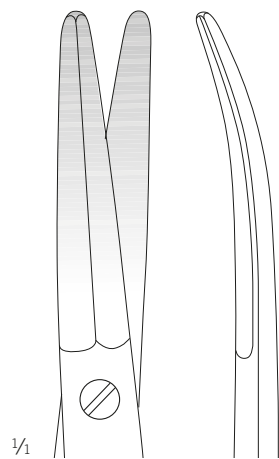

14 cm / 5 4/8"

Chirurgische Scheren, Zahnfleischscheren

Operating Scissors, Gum Scissors

Tijeras quirúrgicas, Tijeras para encías

Ciseaux chirurgicaux, Ciseaux gengivales

Forbici per chirurgia, Forbici per gengiva



Goldman-Fox	Standard	TC GOLD
13 cm / 5 1/8"	11-566-13-07	11-980-13-07

Standard	TC GOLD
11-567-13-07	11-981-13-07



13 cm / 5 1/8"

eine Schneide gezahnt
one toothed cutting edge
una hoja dentada
une lame dentelée
una lama dentata



13 cm / 5 1/8"

eine Schneide gezahnt
one toothed cutting edge
una hoja dentada
une lame dentelée
una lama dentata

Irisscheren

Iris Scissors
Tijeras para iridectomía
Ciseaux iridectomie
Forbici per iridectomia

Scheren

Scissors
Tijeras
Ciseaux
Forbici

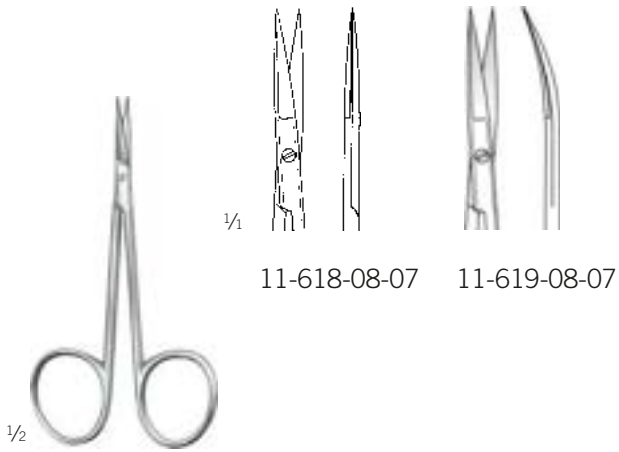

11-618-08-07

11-619-08-07

11-618-08-07 -
11-619-08-07

9 cm / 3 4/8"

sehr fein
very delicate
muy fino
tr s fin
strafino

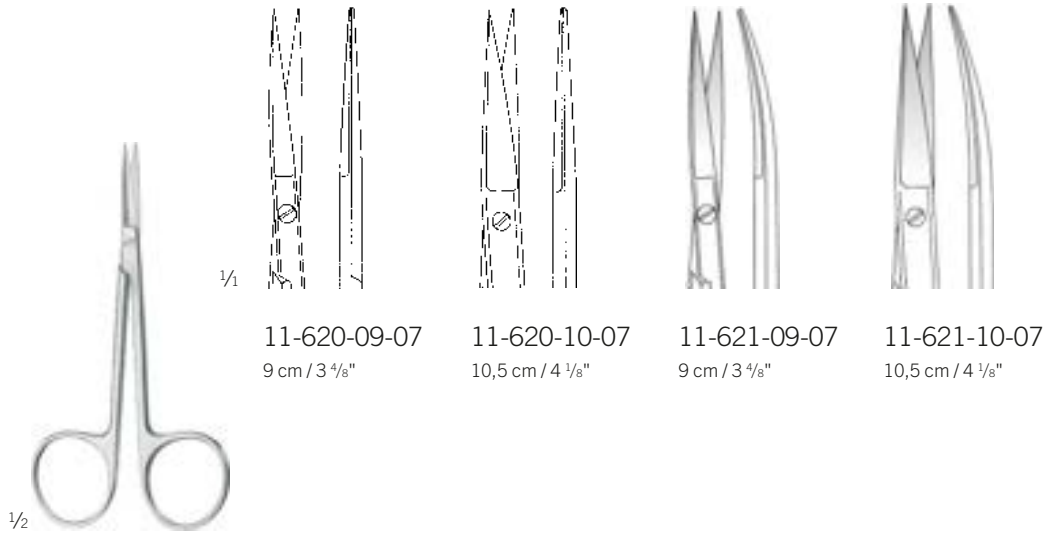

11-620-09-07

9 cm / 3 4/8"

11-620-10-07

10,5 cm / 4 1/8"

11-621-09-07

9 cm / 3 4/8"

11-621-10-07

10,5 cm / 4 1/8"

11-620-09-07 -
11-621-10-07

Irisscheren

Iris Scissors

Tijeras para iridectomía

Ciseaux iridectomie

Forbici per iridectomia

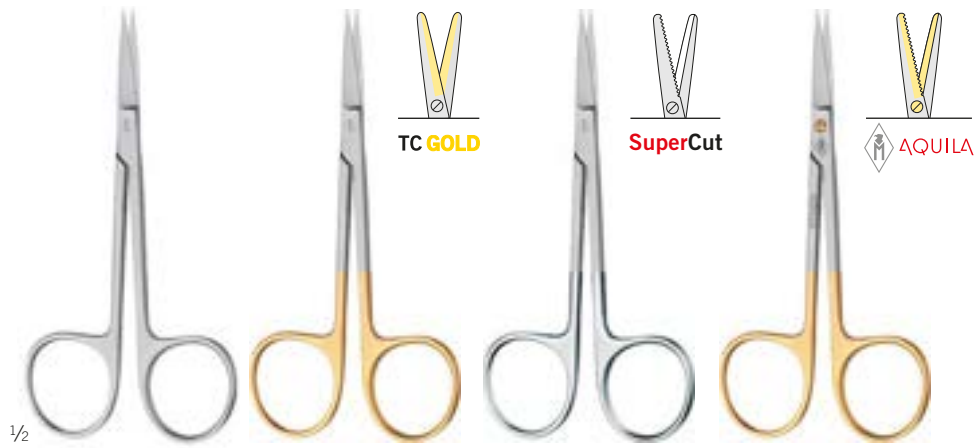

	Standard	TC GOLD	SuperCut	AQUILA
10,5 cm / 4 1/8"			11-672-10-07	
11,5 cm / 4 7/8"	11-630-11-07	11-982-11-07	11-672-11-07	28-464-11-07

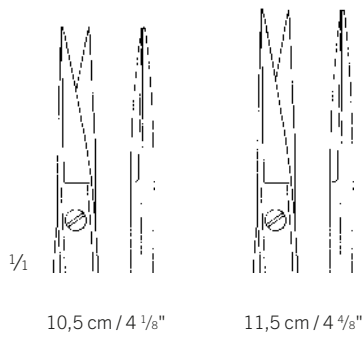

Irisscheren

Iris Scissors
Tijeras para iridectomía
Ciseaux iridectomie
Forbici per iridectomia

Scheren

Scissors
Tijeras
Ciseaux
Forbici

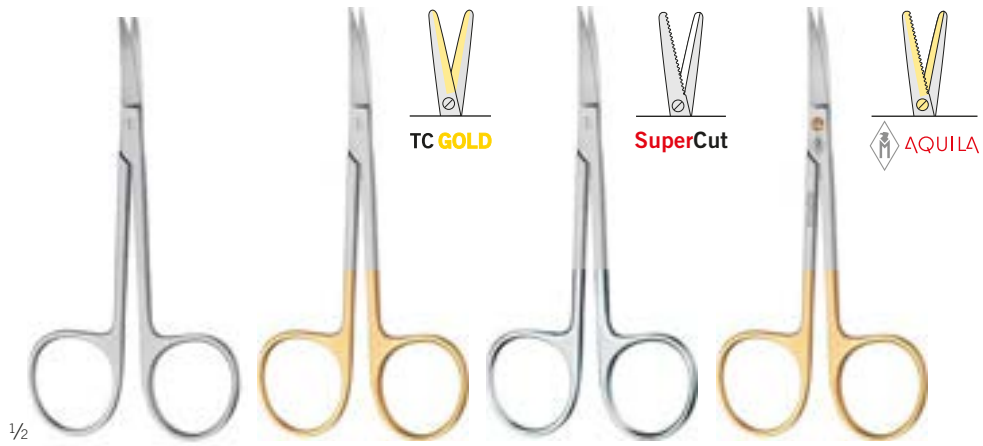

	Standard	TC GOLD	SuperCut	AQUILA
10,5 cm / 4 1/8"			11-673-10-07	
11,5 cm / 4 5/8"	11-631-11-07	11-983-11-07	11-673-11-07	28-465-11-07

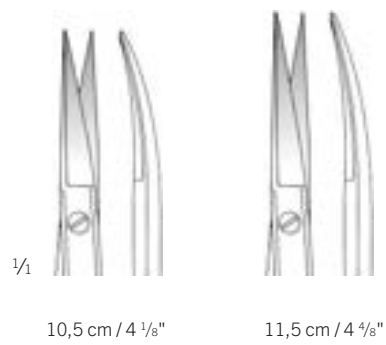

Irisscheren

Iris Scissors

Tijeras para iridectomía

Ciseaux iridectomie

Forbici per iridectomia

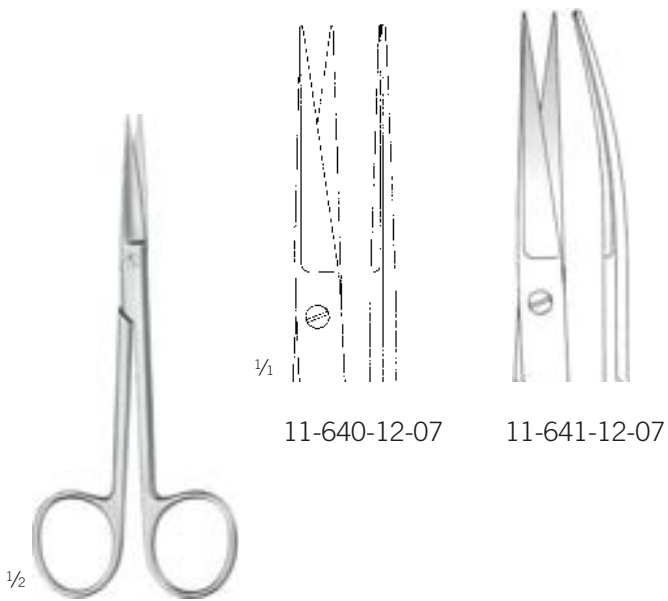

11-640-12-07 -
11-641-12-07
12,5 cm / 4 7/8"

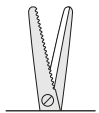

SuperCut

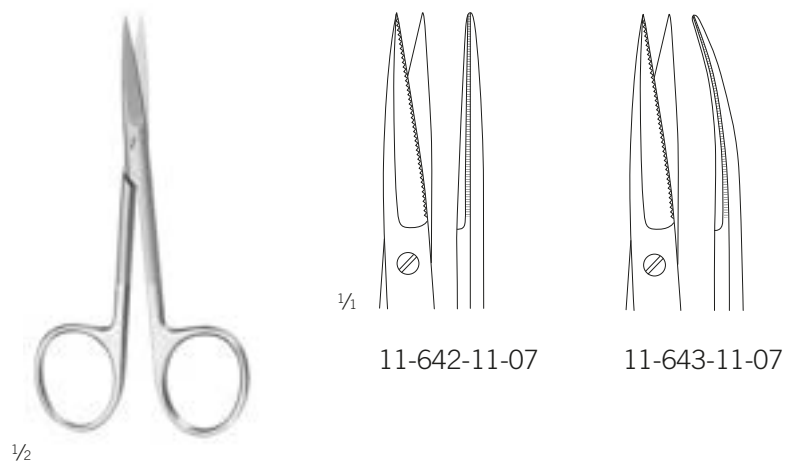

11-642-11-07 -
11-643-11-07

11 cm / 4 3/8"

spitz/spitz
sharp/sharp
agudo/agudo
pointu/pointu
appuntato/appuntato

Irisscheren

Iris Scissors
Tijeras para iridectomía
Ciseaux iridectomie
Forbici per iridectomia

Scheren

Scissors
Tijeras
Ciseaux
Forbici



11

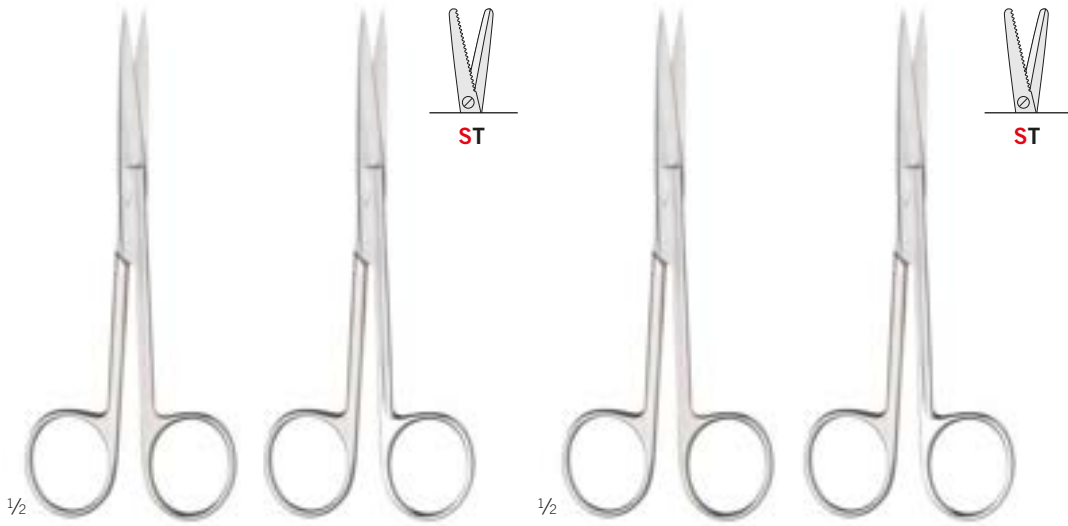

Jabaley	Standard	ST
13 cm / 5 1/8"	11-644-13-07	28-400-13-07

Standard	ST
11-645-13-07	28-401-13-07

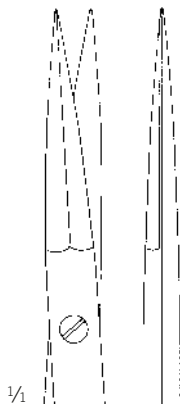

13 cm / 5 1/8"



13 cm / 5 1/8"

Irisscheren

Iris Scissors

Tijeras para iridectomía

Ciseaux iridectomie

Forbici per iridectomia

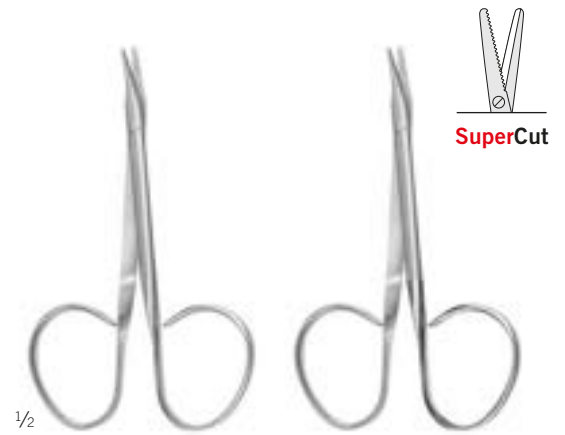
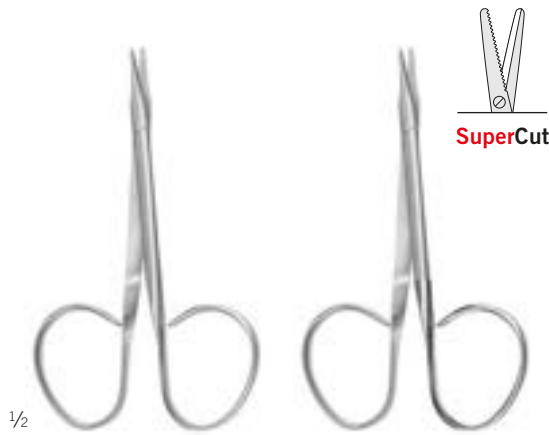

Stevens	Standard	SuperCut
10 cm / 3 7/8"	11-678-10-07	
10,5 cm 4 1/8"		11-676-10-07
11 cm / 4 3/8"	11-682-11-07	

Standard	SuperCut
11-679-10-07	
	11-677-10-07
11-683-11-07	

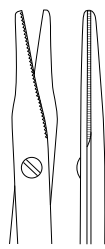
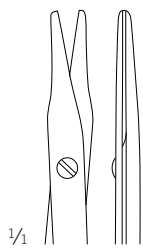

stumpf stumpf
blunt blunt
romo romo
mousse mousse
smusso smusso

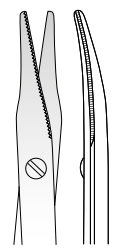
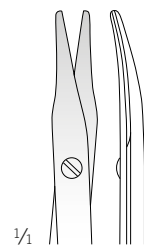

stumpf stumpf
blunt blunt
romo romo
mousse mousse
smusso smusso

Irisscheren

Iris Scissors
Tijeras para iridectomía
Ciseaux iridectomie
Forbici per iridectomia

Scheren

Scissors
Tijeras
Ciseaux
Forbici



Stevens	Standard	SuperCut
10,5 cm 4 ¹ / ₈		11-674-10-07
11 cm 4 ³ / ₈	11-680-11-07	

Standard	SuperCut
	11-675-10-07
11-681-11-07	

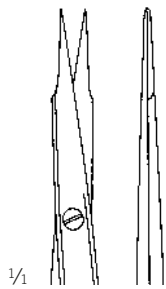

spitz spitz
sharp sharp
agudo agudo
pointu pointu
appuntato appuntato



spitz spitz
sharp sharp
agudo agudo
pointu pointu
appuntato appuntato

Strabismusscheren

Strabismus Scissors

Tijeras para estrabismo

Ciseaux strabisme

Forbici per strabismo



11-690-11-07



11-691-11-07

11-690-11-07 -
11-691-11-07
11,5 cm / 4 1/8"

Mikro-Scheren

Micro Scissors
Micro-Tijeras
Micro-Ciseaux
Micro-Forbici

Scheren

Scissors
Tijeras
Ciseaux
Forbici



11



1 1

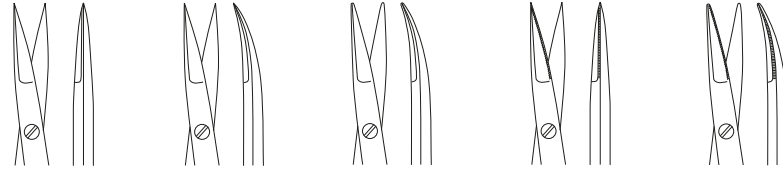

		D	A-SB	D-SB		
15 cm / 5 7/8"		10 mm	10 mm	10 mm		
	st	11-710-15-07	11-711-15-07			
18 cm / 7 1/8"	st	11-710-18-07	11-711-18-07	11-711-19-07	11-710-19-07	11-711-20-07

1 2

11-710-15-07 -
11-711-20-07



1 1

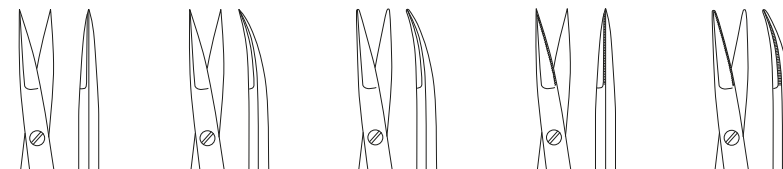

		D	A-SB	D-SB		
15 cm / 5 7/8"		10 mm	10 mm	10 mm		
	st	11-712-15-07	11-713-15-07			
18 cm / 7 1/8"	st	11-712-18-07	11-713-18-07	11-713-19-07	11-712-19-07	11-713-20-07

1 2

11-712-15-07 -
11-713-20-07

A = Adventitia
D = Präparation
A-SB = Adventitia, ein gezahntes Blatt
D-SB = Präparation, ein gezahntes Blatt

A = Adventitia
D = Dissection
A-SB = Adventitia, one serrated blade
D-SB = Dissection, one serrated blade

A = Adventicia
D = Disección
A-SB = Adventicia, una hoja dentada
D-SB = Disección, una hoja dentada

A = Advantice
D = Dissection
A-SB = Advantice, une lame dentelée
D-SB = Dissection, une lame dentelée

A = Avventizia
D = Dissezione
A-SB = Avventizia, una lama dentata
D-SB = Dissezione, una lama dentata

Mikro-Scheren, Mikro-Präparierscheren

Micro Scissors, Micro Dissecting Scissors

Micro-Tijeras, Micro-Tijeras de disección

Micro-Ciseaux, Micro-Ciseaux dissection

Micro-Forbici, Micro-Forbici per dissezione

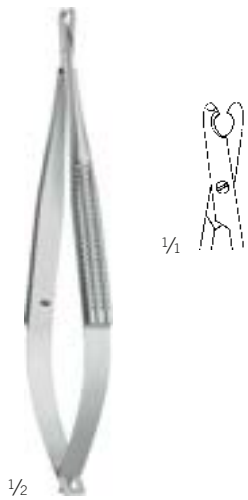

Biemer
11-758-12-07

12 cm / 4 5/8"

Mikro-Venenschere
Micro scissors for veins
Tijeras de micro para venas
Micro-ciseaux pour les veines
Forbici micro per vene

Zum Auffrischen von Gefäßstümpfen. Kein Abgleiten des Gefäßes und glatte, saubere Durchtrennung
For roughening vessel ends, vessel cannot slip off, clean, smooth cut
Renovación de extremos vasculares. Ningún resbalamiento del vaso, cortes limpios y lisos
Pour rafraîchir des moignons vasculaires. Les vaisseaux ne peuvent pas glisser, coupe lisse et propre
Per cruentare le estremità vascolari. Senza scivolamento del vaso, con distacco preciso

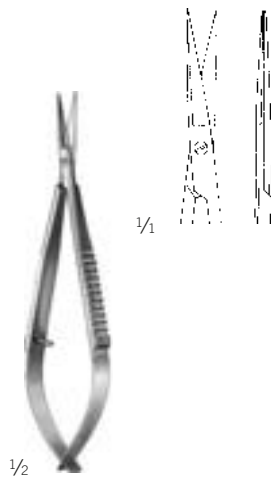

11-760-09-07

10 cm / 3 7/8"

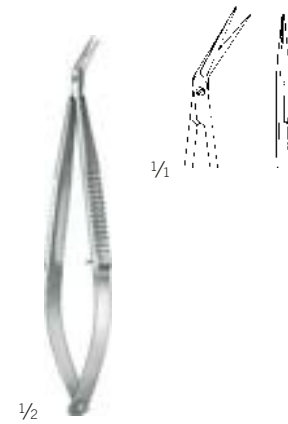

11-761-09-07

9,5 cm / 3 5/8"



aboma
11-765-18-07

18 cm / 7 1/8"

für Lippen-, Kiefer-, Gaumenspalte
for Cleft Palate
para fisura paladar
pour fente du palais
per cheilo-labbro-palato schisi



aboma
11-767-18-07

18 cm / 7 1/8"

für Lippen-, Kiefer-, Gaumenspalte
for Cleft Palate
para fisura paladar
pour fente du palais
per cheilo-labbro-palato schisi

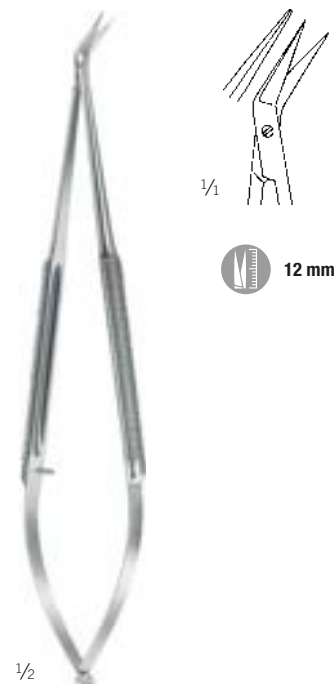

aboma
11-769-18-07

18 cm / 7 1/8"

für Lippen-, Kiefer-, Gaumenspalte
for Cleft Palate
para fisura paladar
pour fente du palais
per cheilo-labbro-palato schisi

Präparierscheren, Face-lift-Scheren, Fadenscheren

Dissecting Scissors, Face-lift Scissors, Stitch Scissors

Tijeras de disección, Tijeras para Face-Lift, Tijeras para hilos

Ciseaux dissection, Ciseaux pour Face-lift, Ciseaux ligatures

Forbici per dissezione, Forbici per Face-lift, Forbici per legature

Scheren

Scissors

Tijeras

Ciseaux

Forbici

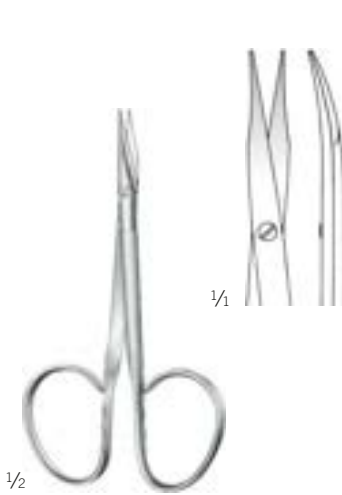

Salyer
11-801-10-07
10 cm / 3 7/8"

für Lippen-, Kiefer-, Gaumenspalte
for Cleft Palate
para fisura paladar
pour fente du palais
per cheilo-labbro-palato schisi



Kaye
11-809-11-07
11 cm / 4 3/8"

beide Schneiden gezahnt
both cutting edges serrated
ambos filos dentados
deux lames dentées
entrambe le lame dentate

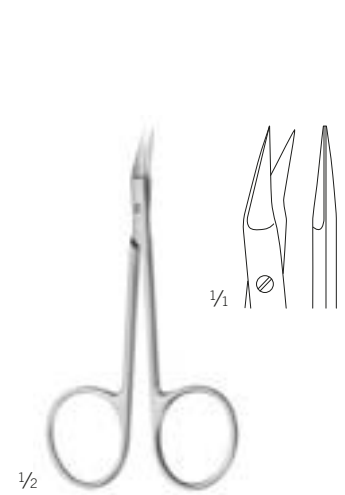

O'Brian
11-821-09-07
9 cm / 3 4/8"

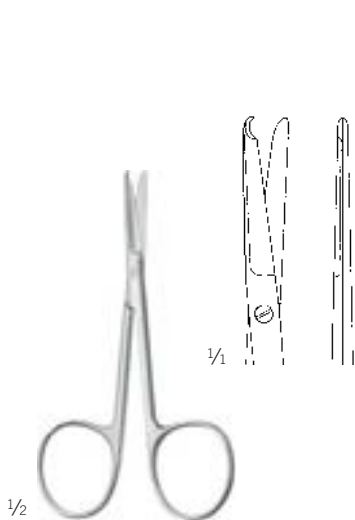

Spencer
11-824-09-07
9 cm / 3 4/8"

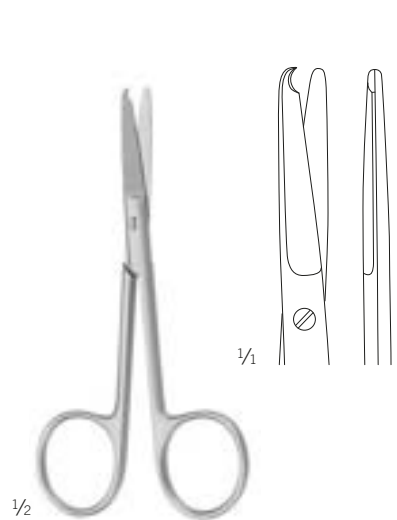

Spencer
11-824-10-07
10,5 cm / 4 1/8"

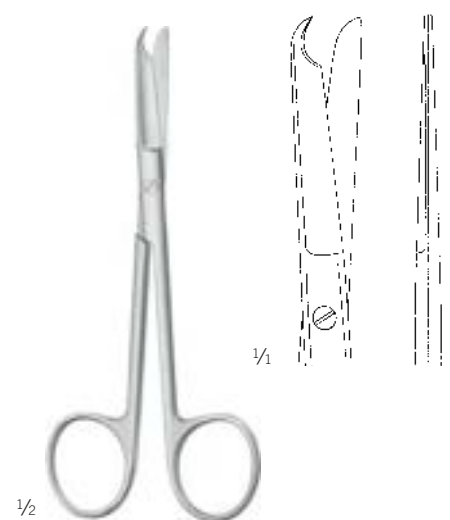

Spencer
11-826-13-07
13 cm / 5 1/8"

Fadenscheren, Drahtscheren

Stitch Scissors, Wire Cutting Scissors

Tijeras para hilos, Tijeras para cortar hilos de acero

Ciseaux ligatures, Ciseaux coupe-fil

Forbici per legature, Forbici per tagliare fili metallici

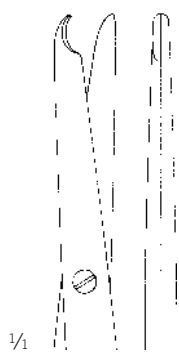

11-830-14-07
14,5 cm / 5 7/8"

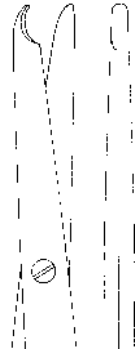

11-830-18-07
18 cm / 7 1/8"

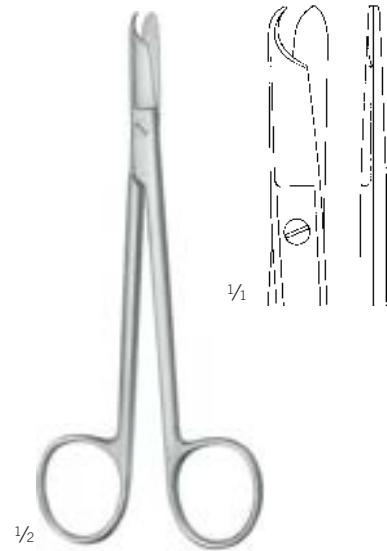

Littauer
11-834-14-07
14 cm / 5 4/8"

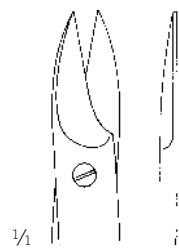

11-874-10-07
10 cm / 3 7/8"



11-875-10-07
10 cm / 3 7/8"



11-878-12-07
12 cm / 4 5/8"
eine Schneide gezahnt
one toothed cutting edge
una hoja dentada
une lame dentelée
una lama dentata



11-879-12-07
12 cm / 4 5/8"
eine Schneide gezahnt
one toothed cutting edge
una hoja dentada
une lame dentelée
una lama dentata

Beebee
11-874-10-07 -
11-879-12-07

Ligaturscheren

Ligature Scissors
Tijeras para ligaduras
Ciseaux pour ligatures
Forbici per legature

Scheren

Scissors
Tijeras
Ciseaux
Forbici

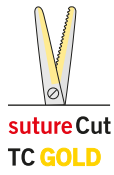

suture Cut
TC GOLD

11

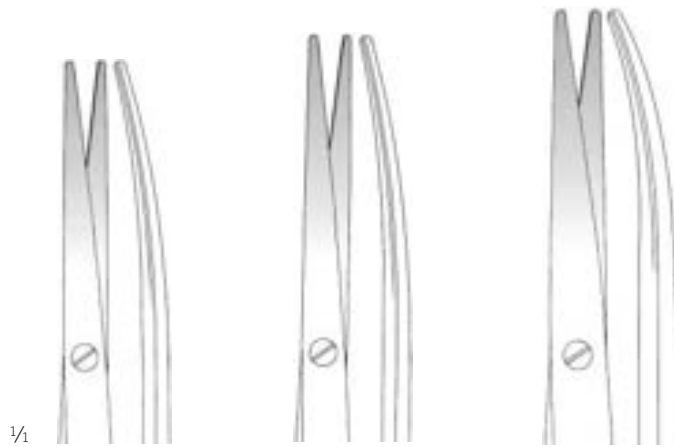

11-914-14-07
14,5 cm / 5 3/4"

11-914-18-07
18 cm / 7"

11-914-20-07
20,5 cm / 8"



1/2

11-914-14-07 -
11-914-30-07

für Synthetik-Nahtmaterial,
eine Schneide gezahnt

for synthetic suture material,
one toothed cutting edge

para hilos de sutura sintéticos,
una hoja dentada

pour matériel de suture synthétique,
une lame dentelée

per materiale di sutura sintetico,
una lama dentata

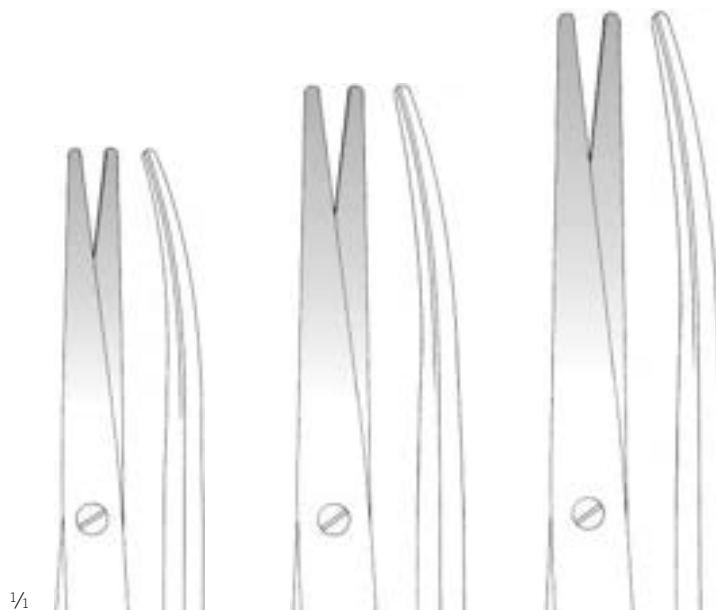

1/4

11-914-23-07
23 cm / 9"

11-914-25-07
25 cm / 9 3/4"

11-914-30-07
30 cm / 11 5/8"

Ligaturscheren
 Ligature Scissors
 Tijeras para ligaduras
 Ciseaux pour ligatures
 Forbici per legature

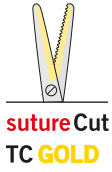

1/2

11-915-14-07 -
 11-915-23-07

für Synthetik-Nahtmaterial,
 eine Schneide gezahnt

for synthetic suture material,
 one toothed cutting edge

para hilos de sutura sintéticos,
 una hoja dentada

pour matériel de suture synthétique,
 une lame dentelée

per materiale di sutura sintetico,
 una lama dentata



1/1

11-915-14-07
 14,5 cm / 5 3/4"



11-915-17-07
 17 cm / 6 3/4"



11-915-23-07
 23 cm / 9"

TCC-BlackLine-Scheren

TCC-BlackLine Scissors

Tijeras TCC-BlackLine

Ciseaux TCC-BlackLine

Forbici TCC-BlackLine

Scheren

Scissors

Tijeras

Ciseaux

Forbici



TCC BlackLine

finoLine TC GOLD



11



1/2

11-916-14-07 -
11-916-20-07

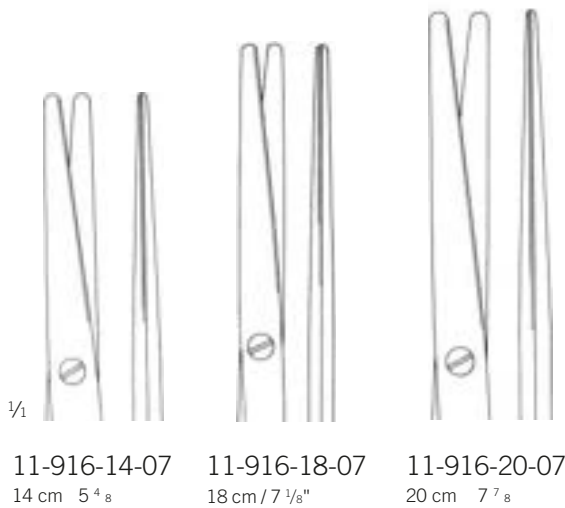

1/1

11-916-14-07
14 cm / 5 4/8"

11-916-18-07
18 cm / 7 1/8"

11-916-20-07
20 cm / 7 7/8"



1/2

Tönnis-Adson TCC-BlackLine
11-919-14-07 -
11-919-18-07

sehr fein
very delicate
muy fino
très fin
strafino

Keramik-Beschichtung,
eine Schneide gezahnt

Coated with ceramics,
one toothed cutting edge

Cubierto con material de cerámicas,
una hoja dentada

Recouvert avec matériau de la
céramique, une lame dentelée

Ricoprito con materiale di ceramica,
una lama dentata

Präparierscheren

Dissecting Scissors
 Tijeras de disección
 Ciseaux dissection
 Forbici per dissezione

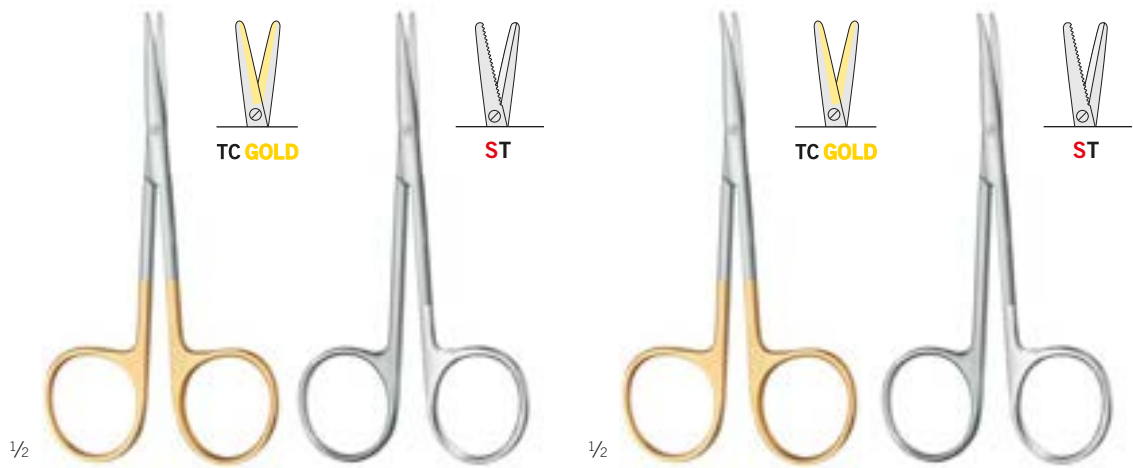

Knapp	TC GOLD	ST
12,5 cm / 4 7/8"	11-934-12-07	28-404-12-07

TC GOLD	ST
11-935-12-07	28-405-12-07



12,5 cm / 4 1/8"



12,5 cm / 4 1/8"

Präparierscheren, Chirurgische Scheren

Dissecting Scissors, Operating Scissors
Tijeras de disección, Tijeras quirúrgicas
Ciseaux dissection, Ciseaux chirurgicaux
Forbici per dissezione, Forbici per chirurgia

Scheren

Scissors
Tijeras
Ciseaux
Forbici



1/2

Metzenbaum-Thorek
11-945-20-07 -
11-945-28-07

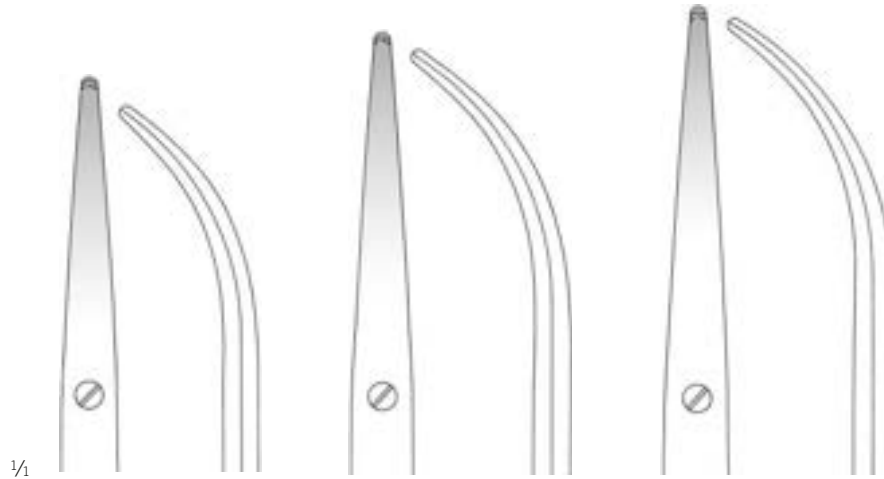

1/4

11-945-20-07
20 cm / 7 7/8"

11-945-23-07
23 cm / 9"

11-945-28-07
28 cm / 11"



1/2

Lexer
11-950-10-07 -
11-951-10-07

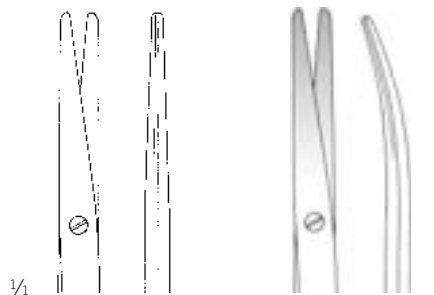

1/4

11-950-10-07

11-951-10-07

Präparierscheren

Dissecting Scissors

Tijeras de disección

Ciseaux dissection

Forbici per dissezione



Mayo-Lexer	TC GOLD	ST
16 cm / 6 2/8"	11-953-16-07	
16,5 cm / 6 4/8"		11-982-11-07

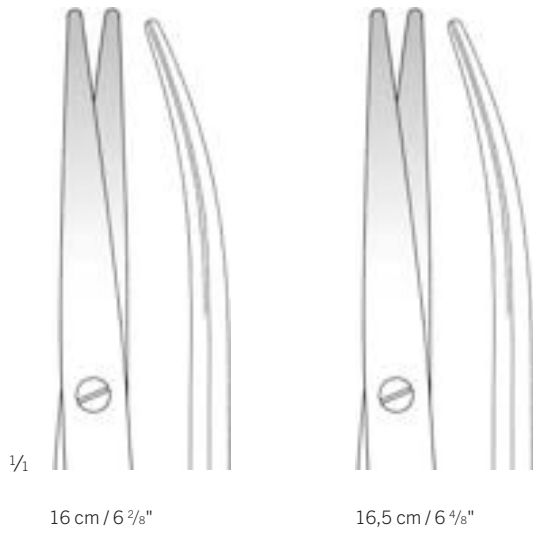

Feine Präparierscheren

Delicate Dissecting Scissors

Tijeras finas de disección

Ciseaux fins dissection

Forbici fini per dissezione

Scheren

Scissors

Tijeras

Ciseaux

Forbici



11



Metzenbaum-Lahey
11-965-14-07

14,5 cm / 5 7/8"
schlankes Modell
slender pattern
modelo delgado
mod le gracile
modello delicato



Siegert
11-968-11-07 -
11-969-11-07
11,5 cm / 4 4/8"

Face-lift-Scheren

Face-lift Scissors

Tijeras para Face-Lift

Ciseaux pour Face-lift

Forbici per Face-lift

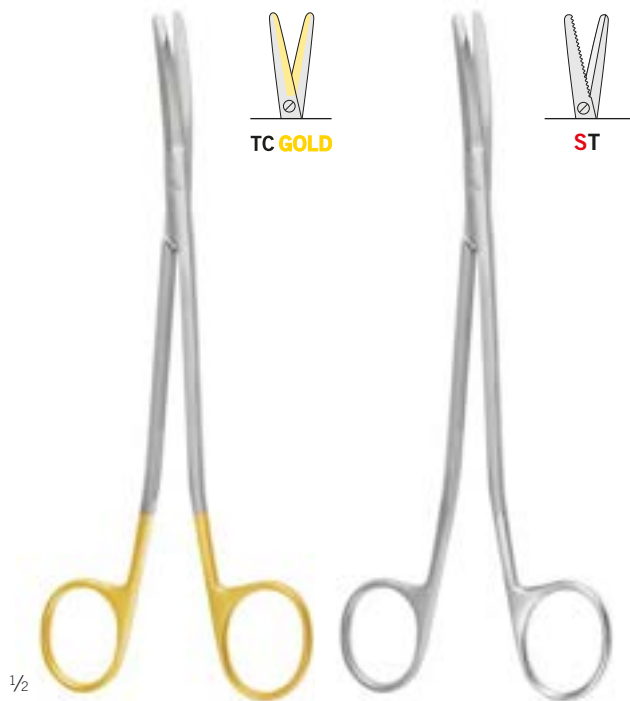

Gorney-Freeman	TC GOLD	ST
17 cm / 6 ⁵ / ₈ "	11-969-17-07	28-445-17-07
19 cm / 7 ⁴ / ₈ "	11-969-19-07	
23 cm / 9"	11-969-23-07	

eine Schneide gezahnt
 one toothed cutting edge
 una hoja dentada
 une lame dentelée
 una lama dentata

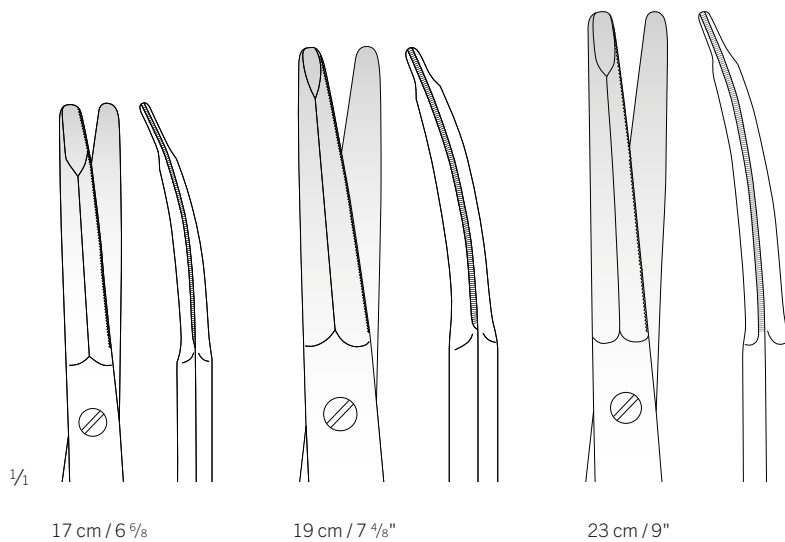

17 cm / 6 ⁵/₈"

19 cm / 7 ⁴/₈"

23 cm / 9"

Face-lift-Scheren

Face-lift Scissors

Tijeras para Face-Lift

Ciseaux pour Face-lift

Forbici per Face-lift

Scheren

Scissors

Tijeras

Ciseaux

Forbici



11

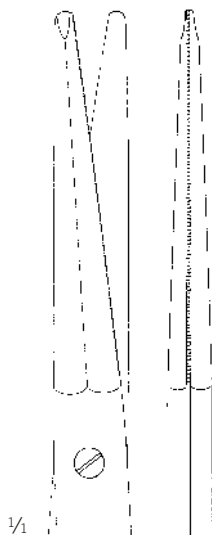

11-970-19-07
20 cm / 7 7/8"

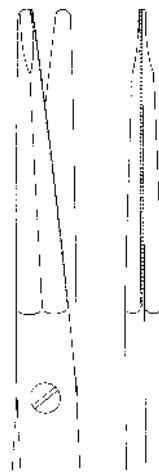

11-970-23-07
23 cm / 9"



11-971-19-07
20 cm / 7 7/8"

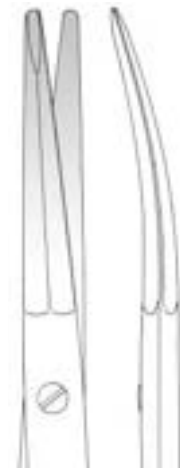

11-971-23-07
23 cm / 9"

Gorney
11-970-19-07 -
11-971-23-07

eine Schneide gezahnt
one toothed cutting edge
una hoja dentada
une lame dentelée
una lama dentata

Feine Präparierscheren

Delicate Dissecting Scissors

Tijeras finas de disección

Ciseaux fins dissection

Forbici fini per dissezione



Rees
11-973-17-07

17 cm / 6 ⁵/₈"

eine Schneide gezahnt
one toothed cutting edge
una hoja dentada
une lame dentelée
una lama dentata

Face-lift-Scheren

Face-lift Scissors

Tijeras para Face-Lift

Ciseaux pour Face-lift

Forbici per Face-lift

Scheren

Scissors

Tijeras

Ciseaux

Forbici



11

Gorney-Freeman	TC GOLD	ST
17 cm / 6 5/8"		28-447-23-07
19 cm / 7 1/2"	11-974-23-07	

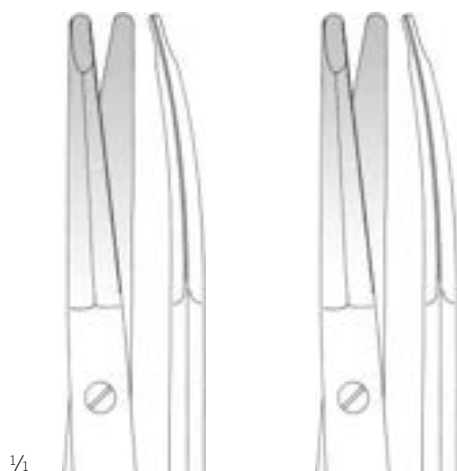

17 cm / 6 5/8"

19 cm / 7 1/2"

Feine Präparierscheren

Delicate Dissecting Scissors

Tijeras finas de disección

Ciseaux fins dissection

Forbici fini per dissezione



1/2

Ragnell
11-991-12-07-
11-991-18-07



1/4

11-991-12-07
12,5 cm / 4 7/8"



11-991-15-07
15 cm / 5 7/8"



11-991-18-07
18 cm / 7 1/8"

Drahtscheren

Wire Cutting Scissors
Tijeras para cortar hilos de acero
Ciseaux coupe-fil
Forbici per tagliare fili metallici

Scheren

Scissors
Tijeras
Ciseaux
Forbici

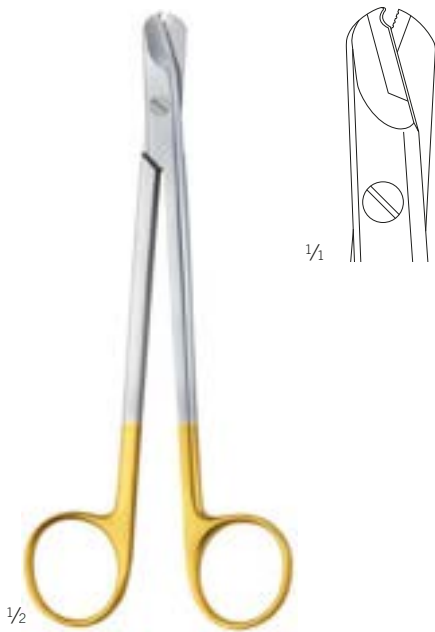

Martin
11-996-16-07

16 cm / 6 2/8"

Drahtschere
Wire cutting scissors
Tijera para alambre
Ciseaux fils
Forbici per fili

max 0,5 mm
weicher Draht
hard wire
alambre duro
fil métallique raide
filo rigido

Mikro-Scheren

Micro Scissors

Micro-Tijeras

Micro-Ciseaux

Micro-Forbici

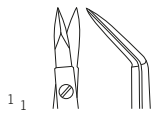

24-850-01-07



9 mm

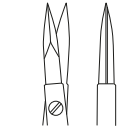

24-850-02-07



12 mm

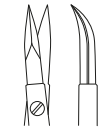

24-850-03-07



12 mm

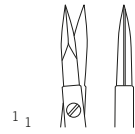

24-850-04-07



12 mm

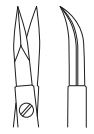

24-850-05-07



12 mm



1 2

1 2

Vannas
24-850-01-07 -
24-850-03-07
12 cm / 4 7/8"

Vannas
24-850-04-07 -
24-850-05-07
16 cm / 6 2/8"

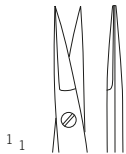

24-850-10-07



12 mm

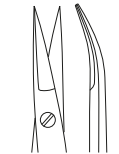

24-850-11-07



12 mm

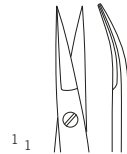

12 mm

1 2

1 2

Millesi
24-850-10-07 -
24-850-11-07
16 cm / 6 2/8"

acobson
24-850-15-07
18,5 cm / 7 2/8"

Mikro-Scheren

Micro Scissors
Micro-Tijeras
Micro-Ciseaux
Micro-Forbici

Scheren

Scissors
Tijeras
Ciseaux
Forbici



1 2

asargil
24-850-20-07 -
24-850-24-07

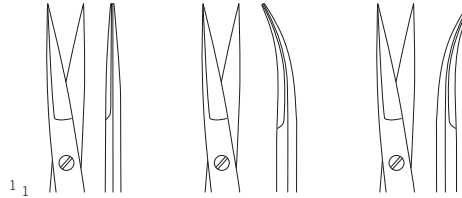



		15 mm	15 mm	15 mm
16,5 cm / 6 7/8"		24-850-20-07	24-850-21-07	
20 cm / 7 7/8"		24-850-22-07	24-850-23-07	24-850-24-07

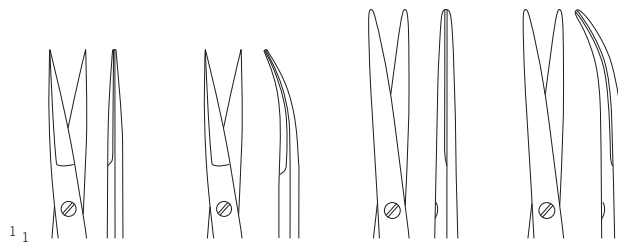

1 2

asargil
24-850-25-07 -
24-850-33-07



		A	A	D	D
		15 mm	15 mm		
20 cm / 7 7/8"				24-850-30-07	24-850-31-07
22,5 cm / 8 7/8"		24-850-25-07	24-850-26-07	24-850-33-07	24-850-32-07
24,5 cm / 9 5/8"			24-850-28-07		

A = Adventitia
D = Präparation
A-SB = Adventitia, ein gezahntes Blatt
D-SB = Präparation, ein gezahntes Blatt

A = Adventitia
D = Dissection
A-SB = Adventitia, one serrated blade
D-SB = Dissection, one serrated blade

A = Adventicia
D = Disección
A-SB = Adventicia, una hoja dentada
D-SB = Disección, una hoja dentada

A = Advantice
D = Dissection
A-SB = Advantice, une lame dentelée
D-SB = Dissection, une lame dentelée

A = Avventizia
D = Dissezione
A-SB = Avventizia, una lama dentata
D-SB = Dissezione, una lama dentata

Mikro-Scheren

Micro Scissors

Micro-Tijeras

Micro-Ciseaux

Micro-Forbici



Fahlbusch
24-850-50-07
16,5 cm / 6 4/8"

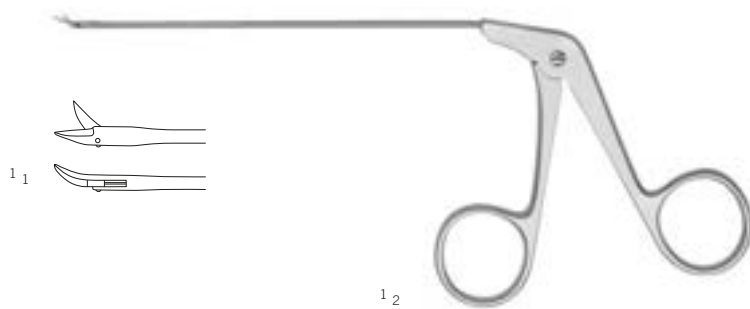

Caspar
24-850-60-07
11,5 cm / 4 4/8"

Irisscheren

Iris Scissors
Tijeras para iridectomía
Ciseaux iridectomie
Forbici per iridectomia

Scheren

Scissors
Tijeras
Ciseaux
Forbici



11

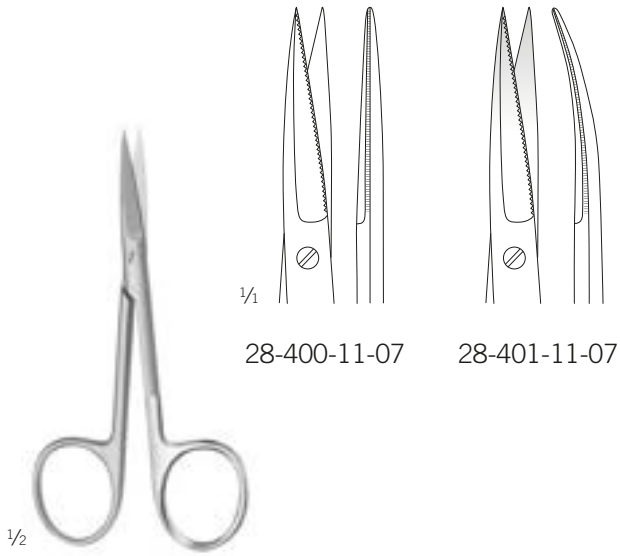

28-400-11-07 -
28-401-11-07

11 cm / 4 ³/₈"

spitz/spitz
sharp/sharp
agudo/agudo
pointu/pointu
appuntato/appuntato



Iris
28-402-10-07 -
28-403-10-07

10,5 cm / 4 ¹/₈"

spitz/spitz
sharp/sharp
agudo/agudo
pointu/pointu
appuntato/appuntato

Scheren, Irisscheren

Scissors, Iris Scissors

Tijeras, Tijeras para iridectomía

Ciseaux, Ciseaux iridectomie

Forbici, Forbici per iridectomia

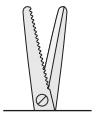

ST



Iris
28-402-11-07 -
28-403-11-07
11,5 cm / 4 5/8"

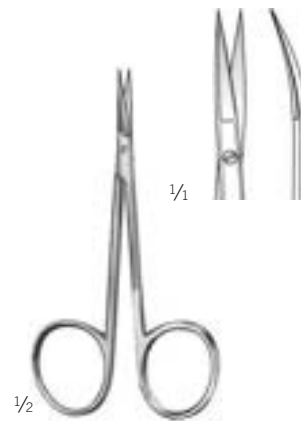

Micro-Iris
28-403-09-07
9 cm / 3 4/8"



Iris
28-404-11-07 -
28-405-11-07
11,5 cm / 4 5/8"

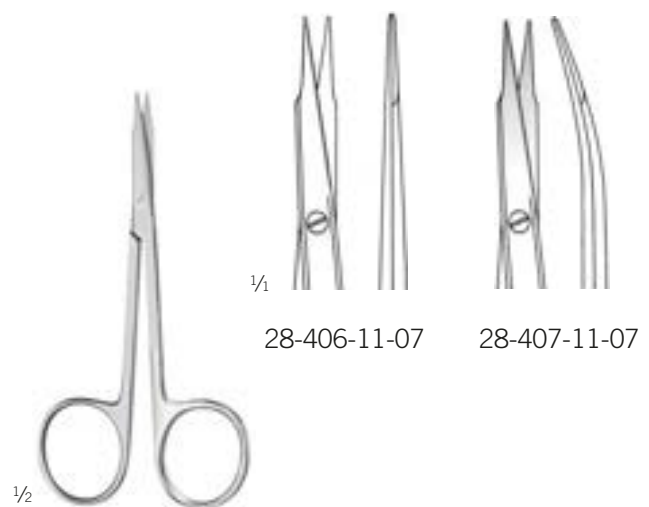

Stevens
28-406-11-07 -
28-407-11-07
11,5 cm / 4 5/8"

Scheren

Scissors
Tijeras
Ciseaux
Forbici

Scheren

Scissors
Tijeras
Ciseaux
Forbici



Greenberg PAR
28-415-11-07
11,5 cm / 4 1/8"



Ragnell-Kilner
28-417-13-07 -
28-417-18-07



28-417-13-07
13 cm / 5 1/8"

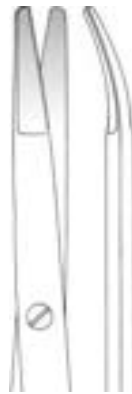

28-417-15-07
15 cm / 5 7/8"



28-417-18-07
18 cm / 7 1/8"

Scheren

Scissors

Tijeras

Ciseaux

Forbici

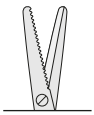

ST



1/1



28-439-12-07
12 cm / 4 5/8"



28-439-16-07
16 cm / 6 2/8"



28-439-18-07
18 cm / 7 1/8"

Reynolds- ameson
28-439-12-07 -
28-439-18-07

1/2



1/1



Stevens
28-441-13-07
13 cm / 5 1/8"

1/2



1/1

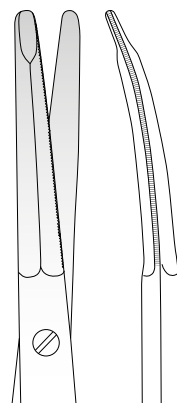

28-443-17-07
17 cm / 6 6/8"

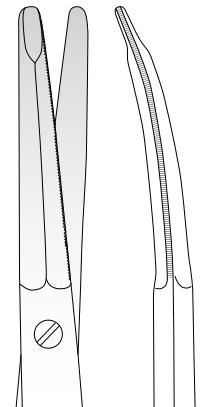

28-443-19-07
19 cm / 7 4/8"

Gorney
28-443-17-07 -
28-443-19-07

Scheren

Scissors
Tijeras
Ciseaux
Forbici

Scheren

Scissors
Tijeras
Ciseaux
Forbici



11

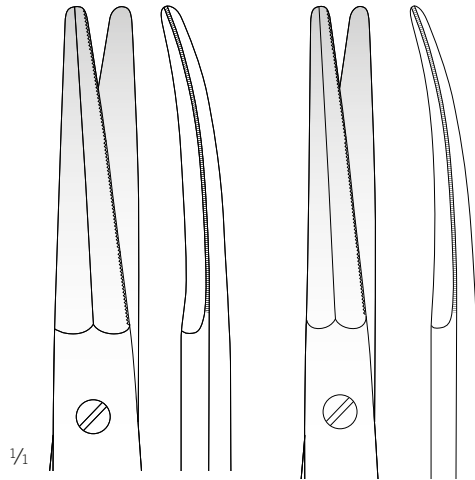

28-449-17-07
17 cm / 6 5/8"

28-449-23-07
23 cm / 9"

Kaye
28-449-17-07 -
28-449-23-07

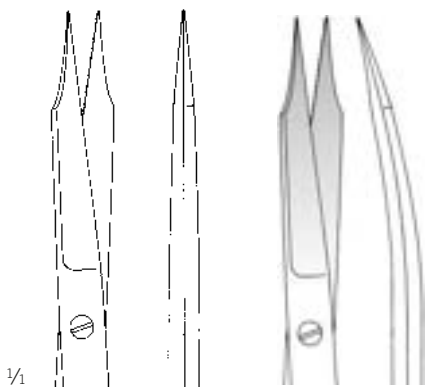

28-450-13-07

28-451-13-07

Fox
28-450-13-07 -
28-451-13-07
13 cm / 5 1/8"



Fomon
28-457-12-07
12,5 cm / 4 7/8"

Scheren

Scissors

Tijeras

Ciseaux

Forbici



1/1

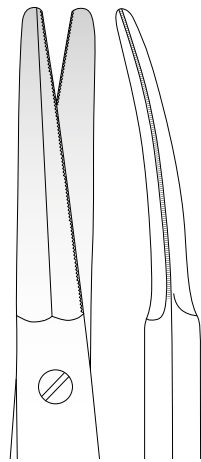

28-499-17-07
17 cm / 6 5/8"

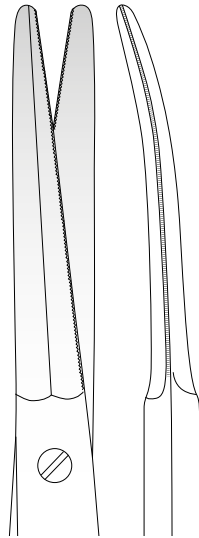

28-499-19-07
19 cm / 7 4/8"

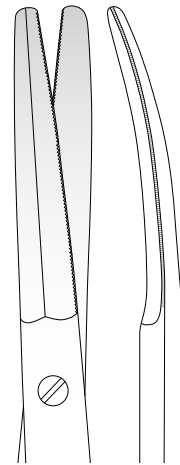

28-499-23-07
23 cm / 9"

1/2

Kaye

28-499-17-07 -

28-499-23-07

beide Schneiden gezahnt
both cutting edges serrated
ambos filos dentados
deux lames dentées
entrambe le lame dentate

Nasenscheren

Nasal Scissors
Tijeras nasales
Ciseaux nasaux
Forbici nasali

Scheren

Scissors
Tijeras
Ciseaux
Forbici



Gregory
28-501-14-07
14,5 cm / 5 6/8"
gezahnt
toothed
dentada
dentelés
dentate



Kaye
28-503-15-07 -
28-503-18-07
eine Schneide gezahnt
one toothed cutting edge
una hoja dentada
une lame dentelée
una lama dentata

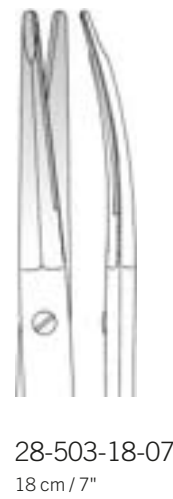

28-503-18-07
18 cm / 7"

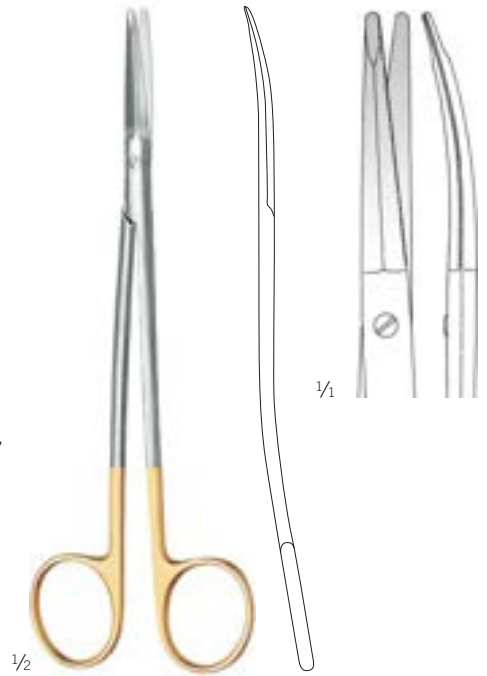

Stella-S
28-505-18-07
18 cm / 7"
eine Schneide gezahnt
one toothed cutting edge
una hoja dentada
une lame dentelée
una lama dentata

Scheren

Scissors

Tijeras

Ciseaux

Forbici



Gorney
28-521-18-07

17,5 cm / 6 7/8"

eine Schneide gezahnt
one toothed cutting edge
una hoja dentada
une lame dentelée
una lama dentata



Freeman-Kaye
28-525-18-07

18 cm / 7"

eine Schneide gezahnt
one toothed cutting edge
una hoja dentada
une lame dentelée
una lama dentata



Freeman
28-529-23-07

23 cm / 9"

eine Schneide gezahnt
one toothed cutting edge
una hoja dentada
une lame dentelée
una lama dentata

Pinzetten
Forceps
Pinzas
Pinces
Pinze

12



Anatomische Pinzetten

Dissecting Forceps

Pinzas de disección

Pinces dissection

Pinze per dissezione

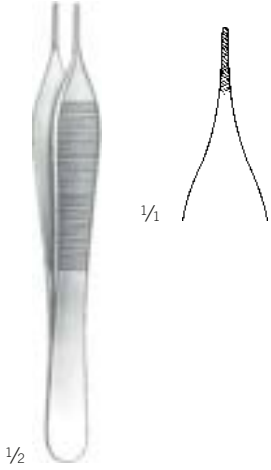

Mini-Adson
12-166-12-07
12 cm / 4 5/8"

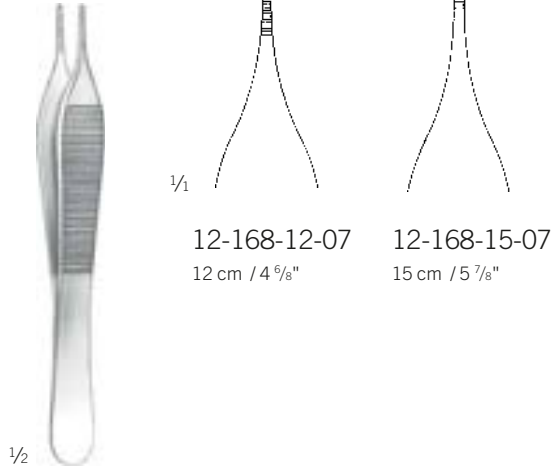

Adson
12-168-12-07 -
12-168-15-07

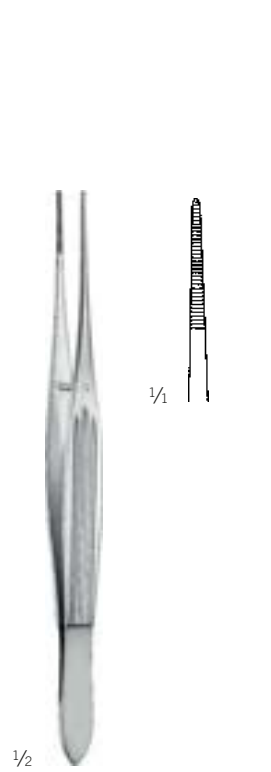

McIndoe
12-170-15-07
15 cm / 5 7/8"

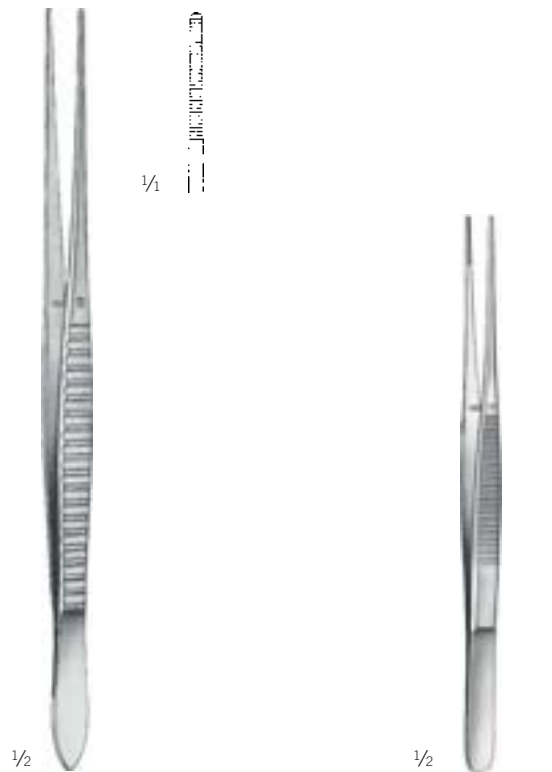

Waugh
12-171-20-07
20 cm / 7 7/8"

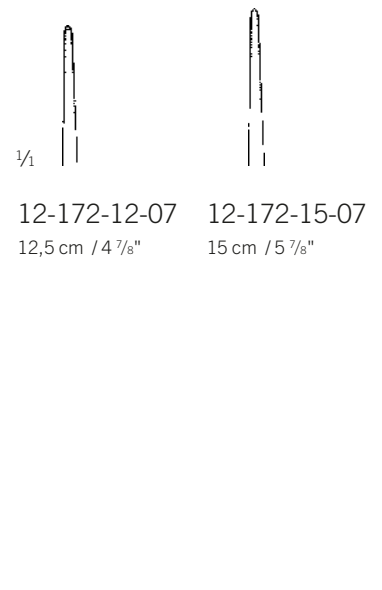

Semken
12-172-12-07 -
12-172-15-07

Anatomische Pinzetten

Dissecting Forceps
Pinzas de disección
Pincers dissection
Pinze per dissezione

Pinzetten

Forceps
Pinzas
Pincers
Pinze

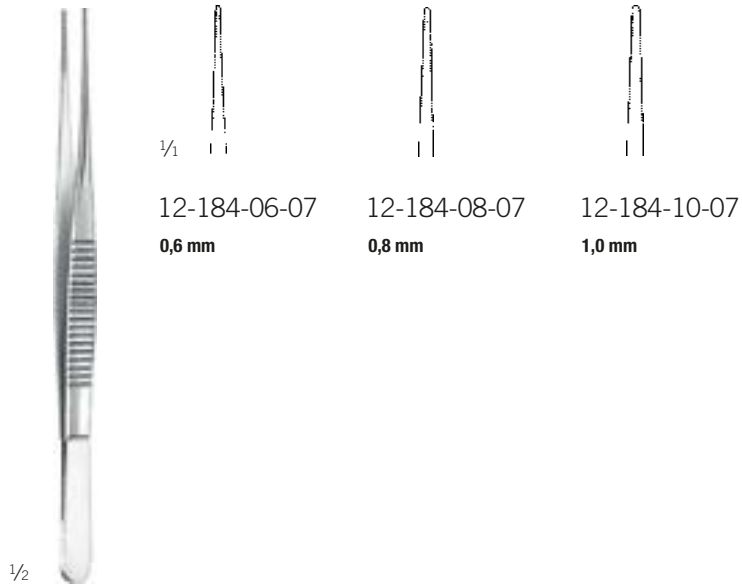

12-184-06-07 -
12-184-10-07
15,5 cm / 6 1/8"

Atrauma



12-184-18-07
17,5 cm / 6 7/8"

12

Chirurgische Pinzetten, Anatomische Pinzetten



Tissue Forceps, Dissecting Forceps

Pinzas de disección con diente, Pinzas de disección

Pinces dissection griffes, Pinces dissection

Pinze per dissezione con denti, Pinze per dissezione

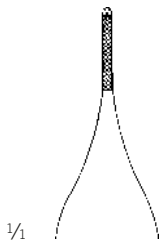
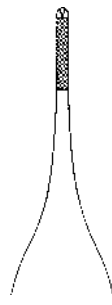
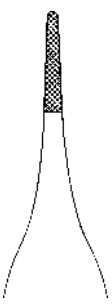
TC GOLD

					
1/2	1/1	<p>12-246-12-07 12 cm / 4 5/8" Miniprofil mini profile perfil mini profil mini mini-profilo</p>  1:2	1/2	1/1	<p>12-246-15-07 15 cm / 5 7/8" Miniprofil mini profile perfil mini profil mini mini-profilo</p>  1:2
<p>Adson 12-246-12-07 - 12-246-15-07</p>			<p>Adson 12-250-12-07 - 12-250-15-07</p>		

					
1/2	1/1	1/2	1/1	1/2	1/1
<p>aboma 12-276-18-07 18 cm / 7 1/8"</p>  1:2		<p>aboma 12-278-18-07 18 cm / 7 1/8"</p>  1:2		<p>aboma 12-279-18-07 18 cm / 7 1/8"</p>	

Chirurgische Pinzetten

Tissue Forceps
 Pinzas de disección con diente
 Pincers dissection griffes
 Pinze per dissezione con denti

Pinzetten

Forceps
 Pinzas
 Pincers
 Pinze

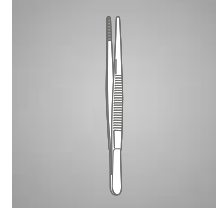

12

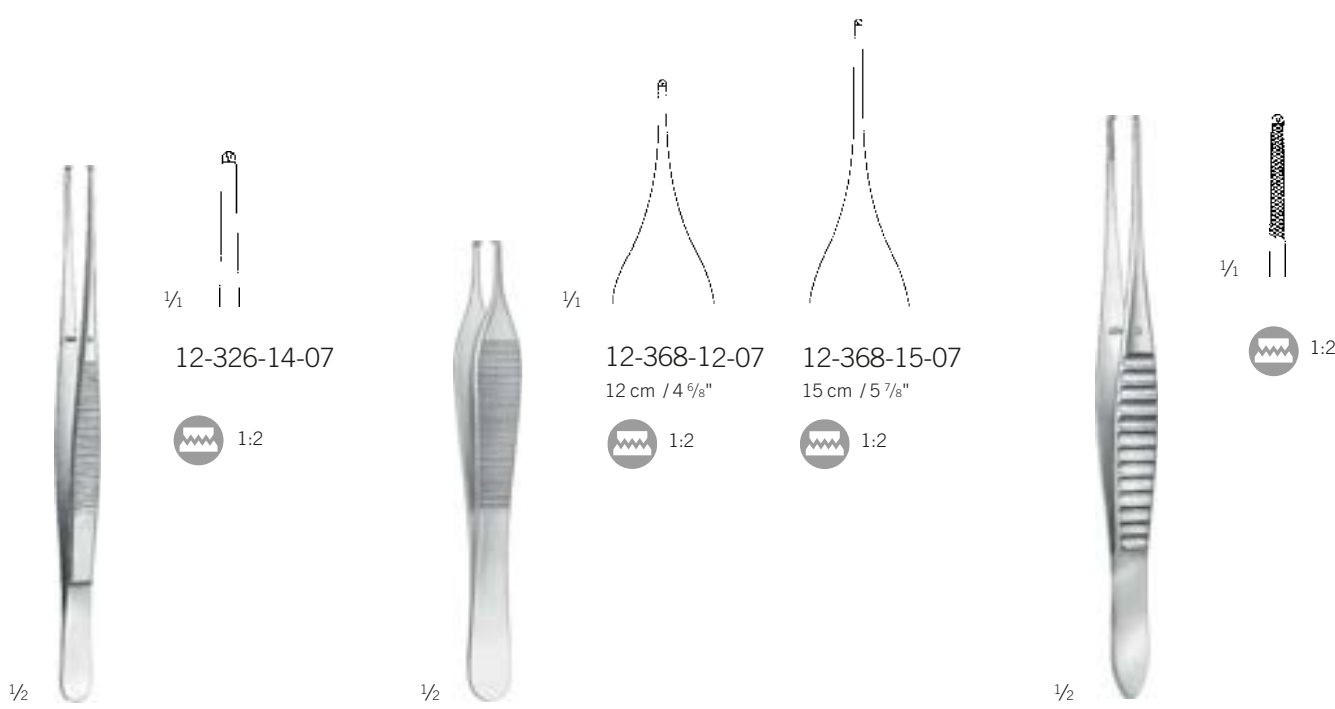

12-326-14-07
 14,5 cm / 5 9/16"

Adson
 12-368-12-07 -
 12-368-15-07

Gillies
 12-370-15-07
 15,5 cm / 6 1/8"



Waugh
 12-371-20-07 -
 12-371-25-07

Semken
 12-372-12-07 -
 12-372-15-07

Chirurgische Pinzetten

Tissue Forceps

Pinzas de disección con diente

Pinces dissection griffes

Pinze per dissezione con denti



1/2



12-384-06-07

0,6 mm



12-384-08-07

0,8 mm



12-384-10-07

1,0 mm

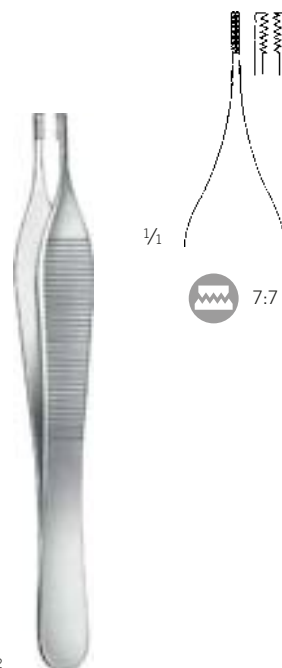

1/2

1/1



12-384-06-07 -
12-384-10-07

15,5 cm / 6 1/8"

Adson-Brown
12-400-12-07
12 cm / 4 5/8"



1/2

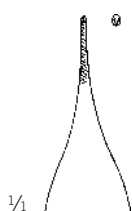

1/1



1/2

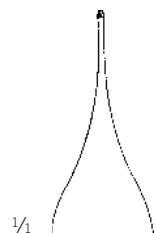

1/1

12-406-12-07
12 cm / 4 5/8"

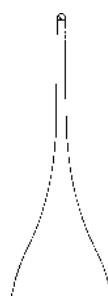

12-406-15-07
15 cm / 5 7/8"



Mini-Adson
12-402-12-07
12 cm / 4 5/8"

Mikro-Adson
12-406-12-07 -
12-406-15-07



1/2

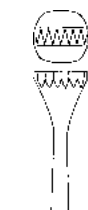

1/1



Nelson
12-466-23-07
23 cm / 9"

Kurze Mikro-Pinzetten

Short Micro Forceps
Micro Pinzas, corto
Micro-Pinces, court
Micro-Pinze, corto

Pinzetten

Forceps
Pinzas
Pinces
Pinze

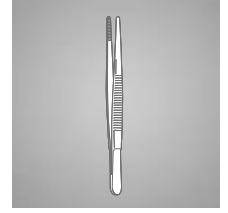

1/2

12-552-01-07 -
12-553-06-07
11 cm / 4 3/8"

1 1			
∅	0.15 mm	0.20 mm	0.30 mm
St	12-552-01-07	12-552-02-07	12-552-03-07

1 1			
∅	0.50 mm	1.2 mm	
St	12-553-01-07	12-553-05-07	12-553-06-07

1 1			
	VD	VD	VD
∅	0.10 mm	0.20 mm	0.30 mm
gewinkelt angled acodada angulée angolata	10	10	10
St	12-552-04-07	12-552-05-07	12-552-06-07

1 1			
∅	0.15 mm	0.20 mm	0.30 mm
St	12-552-07-07	12-552-08-07	12-552-09-07

1 1			
∅	0.50 mm	1.2 mm	
St	12-553-07-07	12-553-08-07	12-553-09-07

1 1			
	VD	VD	VD
∅	0.10 mm	0.20 mm	0.30 mm
gewinkelt angled acodada angulée angolata	10	10	10
St	12-552-10-07	12-552-11-07	12-552-12-07



1/2

12-552-07-07 -
12-553-09-07
11 cm / 4 3/8"

12

Mikro-Pinzetten, Gefäß-Dilatationspinzetten

Micro Forceps, Micro dilating forceps

Micro Pinzas, Micro pinza de dilatación

Micro-Pinces, Micro pince dilater

Micro-Pinze, Micro pinze per dilatazione



1₂

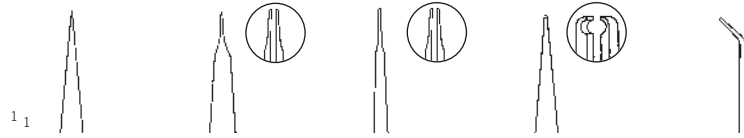

		VD	VD	Pierse	45°
11 cm / 4 3/8"	Ø 0.30 mm	0.20 mm	0.30 mm	0.30 mm	0.30 mm
	St	12-560-00-07		12-560-05-07	12-560-45-07
13,5 cm / 5 3/8"	St	12-561-00-07	12-561-02-07	12-561-03-07	12-561-05-07

Jeweler mod.
12-560-00-07 -
12-561-45-07



1/2

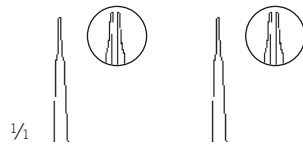

		VD	VD
	Ø	0.20 mm	0.30 mm
	gewinkelt angled acodada angulée angolata	10	10
11 cm / 4 3/8"	St	12-560-02-07	12-560-03-07

Jeweler mod.
12-560-02-07 -
12-560-03-07



1₂



Counter Balance

diamond-coated



			45°		VD	Pierse
	Ø	0.30 mm	0.30 mm	0.30 mm	1.0 x 0.5 mm	0.30 mm
15 cm / 5 7/8"	St	12-562-00-07	12-562-01-07	12-562-02-07	12-562-03-07	12-562-04-07
18 cm / 7 1/8"	St	12-563-00-07	12-563-01-07	12-563-02-07	12-563-03-07	12-563-04-07

12-562-00-07 -
12-563-05-07

Mikro-Pinzetten, Gefäß-Dilatationspinzetten

Micro Forceps, Micro dilating forceps
 Micro Pinzas, Micro pinza de dilatación
 Micro-Pinces, Micro pince dilater
 Micro-Pinze, Micro pinze per dilatazione

Pinzetten

Forceps
 Pinzas
 Pinces
 Pinze

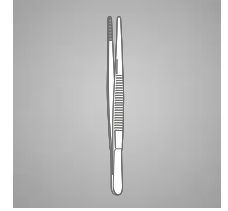

1 2

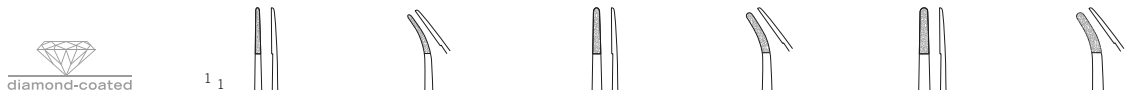

	Ø	0.40 mm	0.40 mm	0.70 mm	0.70 mm	0.80 mm	0.80 mm
15 cm / 5 7/8"	St	12-564-15-07	12-565-15-07	12-566-15-07	12-567-15-07		
	Ti	12-578-15-09	12-579-15-09			12-580-15-09	12-581-15-09
18 cm / 7 1/8"	St	12-564-18-07	12-565-18-07	12-566-18-07	12-567-18-07		
	Ti	12-578-18-09	12-579-18-09			12-580-18-09	12-581-18-09
21 cm / 8 2/8"	St			12-566-21-07	12-567-21-07		
	Ti					12-580-21-09	12-581-21-09

12

12-564-15-07 -
 12-581-21-09



1 2



				45°		VD	Pierse
15 cm / 5 7/8"	Ø	0.30 mm	0.30 mm	0.30 mm	1.0 x 0.5 mm	0.30 mm	0.40 mm
	St	12-591-00-07	12-591-01-07	12-591-02-07	12-591-03-07	12-591-04-07	12-591-05-07
18 cm / 7 1/8"	St	12-592-00-07	12-592-01-07	12-592-02-07	12-592-03-07	12-592-04-07	12-592-05-07

12-591-00-07 -
 12-592-05-07

Mikro-Pinzetten

Micro Forceps

Micro Pinzas

Micro-Pinces

Micro-Pinze





		1:2	1:2	1:2	1:2
15 cm / 5 7/8"	Ø	0.40 mm	0.40 mm	0.70 mm	0.70 mm
	St	12-568-15-07	12-569-15-07	12-570-15-07	12-571-15-07
	Ti	12-582-15-09	12-583-15-09		
18 cm / 7 1/8"	St	12-568-18-07	12-569-18-07	12-570-18-07	12-571-18-07
	Ti	12-582-18-09	12-583-18-09		

1 2

12-568-15-07 -
12-583-18-09



						Atrauma 
15 cm / 5 7/8"	Ø	1.0 x 0.5 mm	1.0 x 0.5 mm	2.0 x 1.0 mm	2.0 x 1.0 mm	1.2 mm
	St	12-574-15-07	12-774-15-07	12-576-15-07	12-776-15-07	12-589-15-07
	Ti	12-586-15-09	12-786-15-09	12-588-15-09	12-787-15-09	12-590-15-09
18 cm / 7 1/8"	St	12-574-18-07	12-774-18-07	12-576-18-07	12-776-18-07	12-589-18-07
	Ti	12-586-18-09	12-786-18-09	12-588-18-09	12-787-18-09	12-590-18-09
21 cm / 8 2/8"	St	12-574-21-07	12-774-21-07	12-576-21-07	12-776-21-07	12-589-21-07
	Ti	12-586-21-09	12-786-21-09	12-588-21-09	12-787-21-09	12-590-21-09

1 2

12-574-15-07 -
12-787-21-09

Mikro-Pinzetten

Micro Forceps
Micro Pinzas
Micro-Pinces
Micro-Pinze

Pinzetten

Forceps
Pinzas
Pinces
Pinze

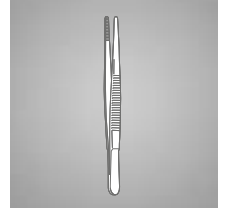

12

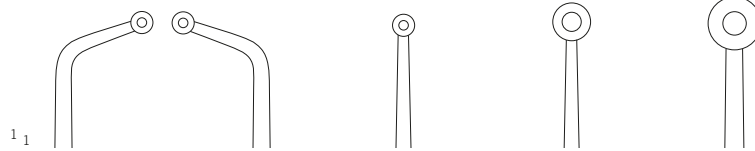

		Samii	Samii	asargil-Samii	asargil-Samii	asargil-Samii
	∅	3.0 mm	3.0 mm	3.0 mm	5.0 mm	7.0 mm
23 cm / 9"		24-852-01-07	24-852-02-07			
24 cm / 9 1/8"				24-852-10-07	24-852-11-07	24-852-12-07

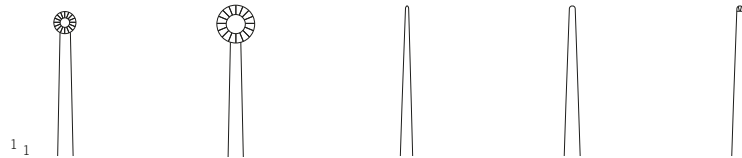

		asargil	asargil	asargil	asargil	asargil
	∅	3.0 mm	5.0 mm	0.6 mm	0.9 mm	
	mm					1:2
18 cm / 7 1/8"				24-852-70-07	24-852-71-07	24-852-72-07
20 cm / 7 7/8"				24-852-73-07	24-852-74-07	
22 cm / 8 5/8"		24-852-25-07	24-852-26-07	24-852-75-07	24-852-76-07	

1₂

24-852-01-07 -
24-852-76-07

Gefäßpinzetten

Vascular Forceps

Pinzas de disección vascular

Pinces dissection vasculaires

Pinze per dissezione vascolari

Atrauma



2,7 mm

2,7 mm

2,0 mm

2,0 mm

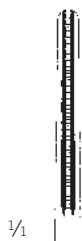

1/1

24-384-16-07
16 cm / 6 2/8"

24-384-20-07
20 cm / 7 7/8"

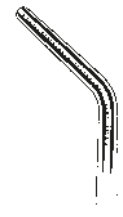

1/1

24-389-16-07
16 cm / 6 2/8"

24-389-20-07
20 cm / 7 7/8"

1/2

De Bakey
24-384-16-07 -
24-384-20-07

1/2

De Bakey
24-389-16-07 -
24-389-20-07

13

Arterienklemmen
Haemostatic Forceps
Pinzas hemostáticas
Pincès hémostatiques
Pinze emostatiche

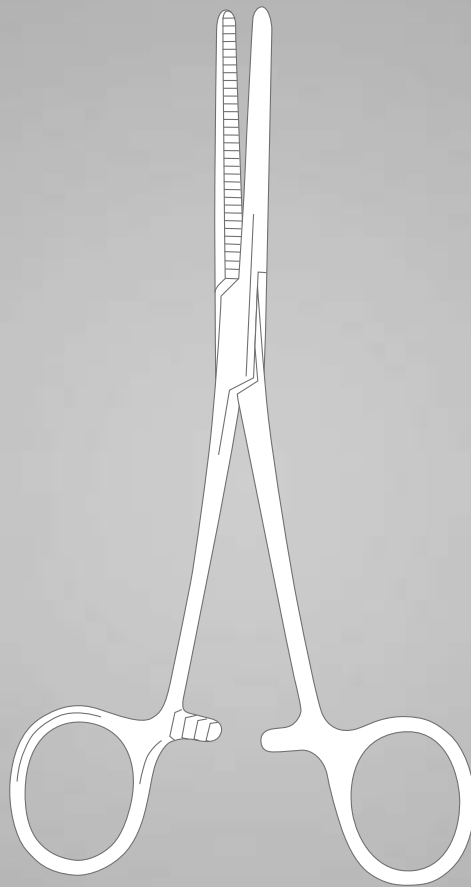

Bulldogklemmen, Arterienklemmen

Bulldog Clamps, Haemostatic Forceps

Clamps Bulldog, Pinzas hemostáticas

Clamps Bulldog, Pincas hémostatiques

Pinze Bulldog, Pinze emostatiche



1/2

Diethrich
13-120-08-07 -
13-121-12-07

1/1

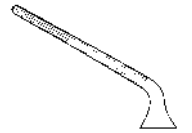
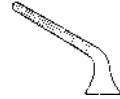

St	13-120-08-07	13-120-10-07	13-120-12-07	13-121-08-07	13-121-10-07	13-121-12-07
	45 mm	50 mm	60 mm	40 mm	45 mm	50 mm
	8 mm	12 mm	20 mm	8 mm	12 mm	20 mm
P	50 g	50 g	50 g	50 g	50 g	50 g

1/1

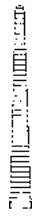

13-310-12-07
12,5 cm / 4 7/8"

13-310-14-07
14,5 cm / 5 6/8"

13-311-12-07
12 cm / 4 6/8"

13-311-14-07
14 cm / 5 4/8"

1/1

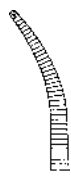
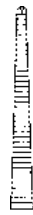

13-312-12-07
12,5 cm / 4 7/8"

13-312-14-07
14,5 cm / 5 6/8"

13-313-12-07
12,5 cm / 4 7/8"

13-313-14-07
14,5 cm / 5 6/8"



1:2



1:2



1:2



1:2

1/2



Halsted-Mosquito
13-310-12-07 -
13-313-14-07

Arterienklemmen

Haemostatic Forceps
Pinzas hemostáticas
Pincès hémostatiques
Pinze emostatiche

Arterienklemmen

Haemostatic Forceps
Pinzas hemostáticas
Pincès hémostatiques
Pinze emostatiche



Ti



1/2

Halsted-Mosquito
13-310-62-09 -
13-313-62-09

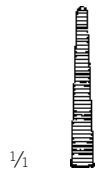

1/1

13-310-62-09
12,5 cm / 4 7/8"

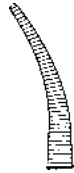

13-311-62-09
12 cm / 4 5/8"



13-312-62-09
12 cm / 4 5/8"



1:2



13-313-62-09
12 cm / 4 5/8"



1:2

13



1/1

13-320-10-07
10 cm / 3 7/8"



13-320-12-07
12 cm / 4 5/8"



13-321-10-07
10 cm / 3 7/8"



13-321-12-07
12 cm / 4 5/8"



1/2

Mikro-Mosquito
13-320-10-07 -
13-323-12-07



1/1

13-322-10-07
10 cm / 3 7/8"



1:2



13-322-12-07
12 cm / 4 5/8"



1:2



13-323-10-07
10 cm / 3 7/8"



1:2



13-323-12-07
12 cm / 4 5/8"



1:2

Arterienklemmen

Haemostatic Forceps
 Pinzas hemostáticas
 Pincas hémostatiques
 Pinze emostatiche



13-324-14-07
 14 cm / 5 1/8"

13-325-14-07
 13,5 cm / 5 3/8"

Providence-Hospital
 13-324-14-07 -
 13-325-14-07

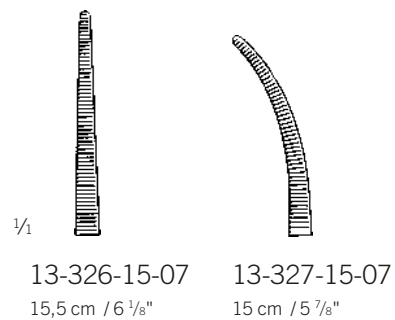

13-326-15-07
 15,5 cm / 6 1/8"

13-327-15-07
 15 cm / 5 7/8"

Leriche
 13-326-15-07 -
 13-329-15-07

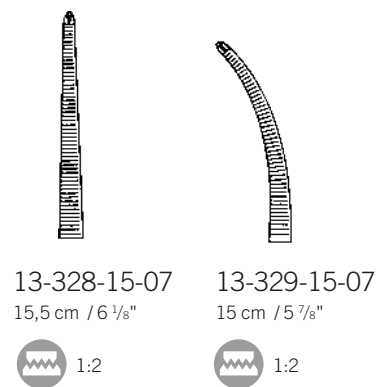

13-328-15-07
 15,5 cm / 6 1/8"

13-329-15-07
 15 cm / 5 7/8"



1/1

Pean
 13-374-13-07
 13,5 cm / 5 3/8"

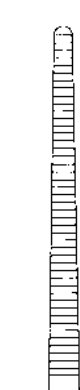
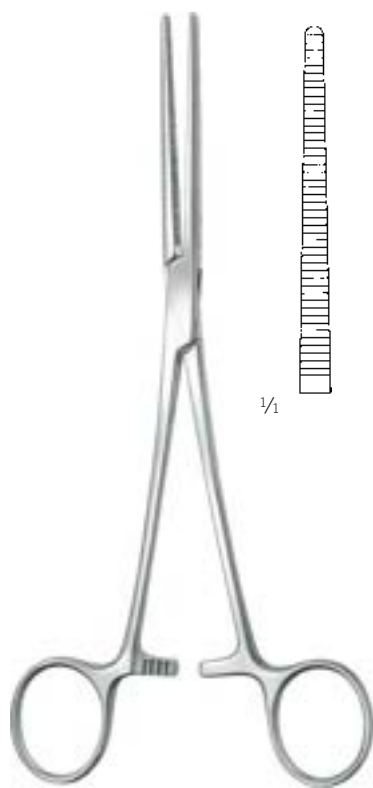

1/1

Pean Rochester
 13-410-16-07
 16,5 cm / 6 4/8"

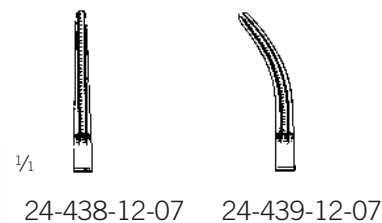

1/1

24-438-12-07

24-439-12-07

De Bakey-Mosquito
 24-438-12-07 -
 24-439-12-07
 12,5 cm / 4 7/8"

Wundhaken
Retractors
Separadores
carteurs
Divaricatori

15

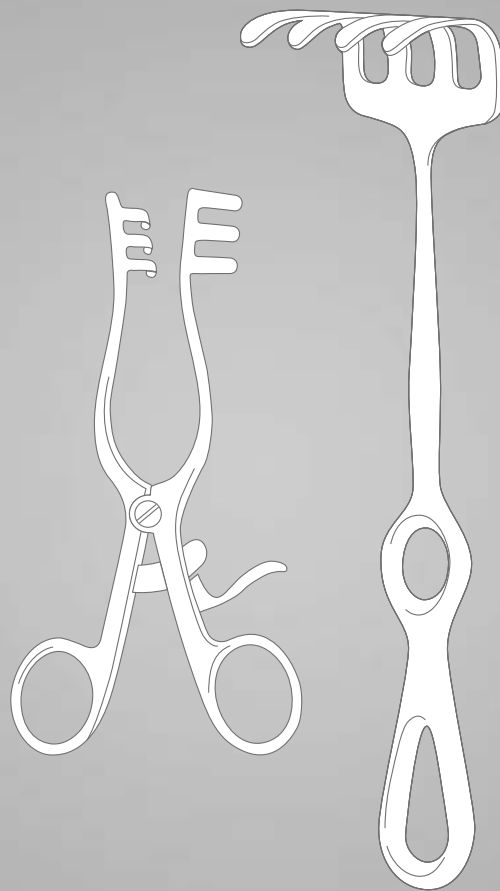

Wundhaken, Häkchen

Retractors, Hooks
Separadores, Ganchitos
carteurs, Crochetes
Divaricatori, Divaricatori

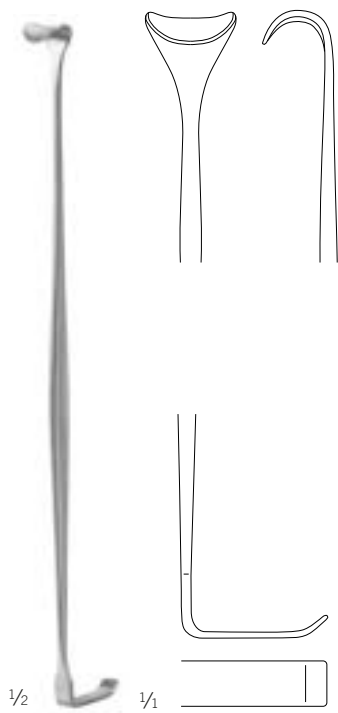

Cope
15-055-01-07
18 cm / 7 1/8"

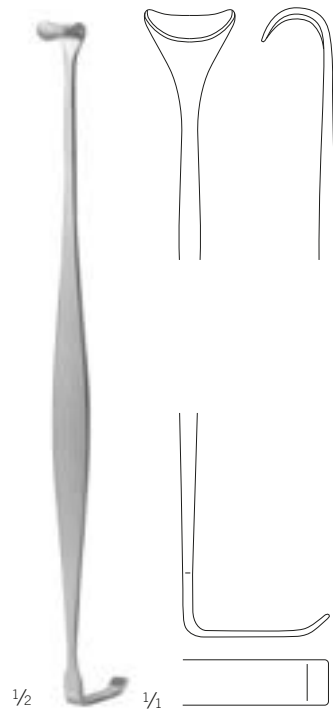

Cope-Walter
15-055-02-07
17,5 cm / 6 7/8"



Barsky
15-056-01-07
15 cm / 5 7/8"



Barsky
15-056-02-07
15 cm / 5 7/8"

Hauthäkchen, Wundhäkchen

Skin Hooks, Hooklets
Ganchitos de piel, Ganchitos
Crochetes pour le peau, Crochetes
Divaricatori per pelle, Divaricatori

Wundhaken

Retractors
Separadores
carteurs
Divaricatori

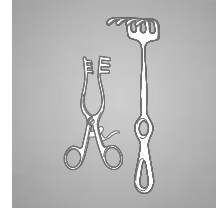

Fig. 1
15-068-01-07



Fig. 2
15-068-02-07



Fig. 3
15-068-03-07

1/2

15-068-01-07 -
15-068-03-07

16 cm / 6 2/8"

scharf
sharp
agudo
pointu
acuto



1/2

O'Connor
15-070-16-07

16 cm / 6 2/8"

scharf
sharp
agudo
pointu
acuto



1/4

15-072-01-07



1/4

15-072-02-07

1/2

Guthrie
15-072-01-07 -
15-072-02-07

16 cm / 6 2/8"

scharf
sharp
agudo
pointu
acuto

Häkchen, Haken

Hooklets, Hooks
Ganchitos, Ganchos
Crochets, Crochets
Uncini



Crile
24-541-20-07
20 cm / 7 $\frac{7}{8}$ "



Adson
24-823-20-07 -
24-824-20-07
20 cm / 7 $\frac{7}{8}$ "



24-824-20-07
scharf
sharp
agudo
pointu
acuto

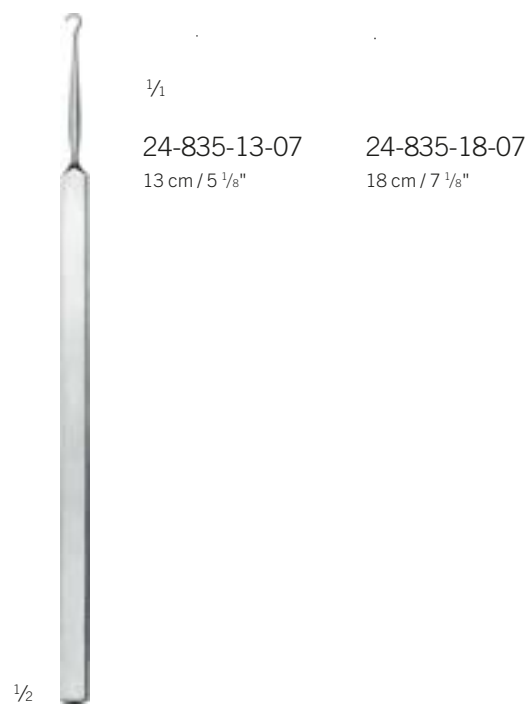

Frazier
24-835-13-07 -
24-835-18-07

Trachealhaken, Wundhäkchen

Tracheal Hooks, Hooklets

Ganchos traqueales, Ganchitos

carteurs pour trachéotomie, Crochetes

Uncini tracheali, Divaricatori

Wundhaken

Retractors

Separadores

carteurs

Divaricatori



ackson
27-155-17-07
18 cm / 7 1/8"

10 mm

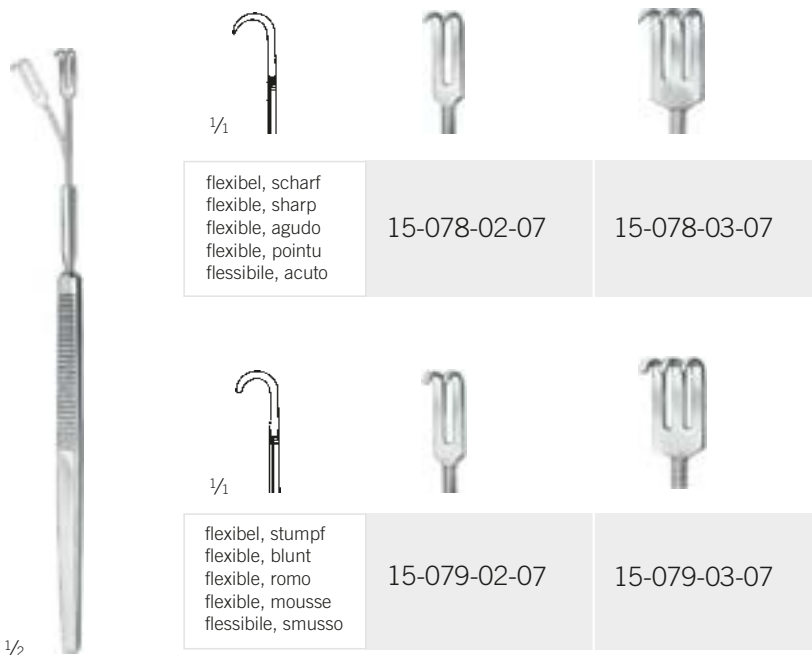

15-078-02-07 -
15-079-03-07
15,5 cm / 6 1/8"

Sattelhäkchen

Saddle Hooks

Ganchos en forma de silla
 - carteurs sous forme de selle
 Divaricatori a forma di sella

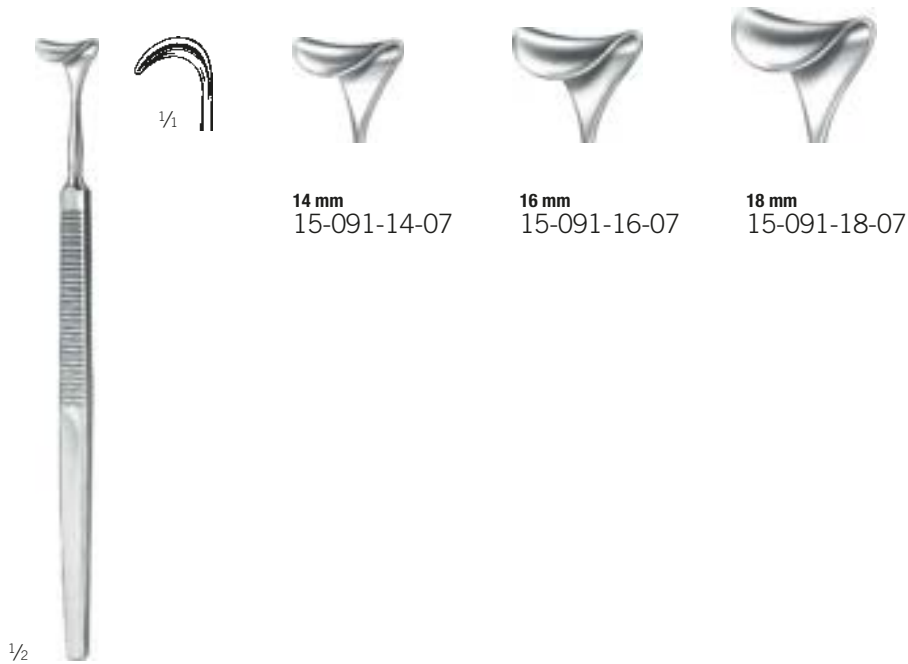

14 mm
 15-091-14-07

16 mm
 15-091-16-07

18 mm
 15-091-18-07

Desmarres
 15-091-14-07 -
 15-091-18-07
 16 cm / 6 2/8"



Fig. 1
 15-151-01-07
 stumpf
 blunt
 romo
 mousse
 smusso
18 x 7 mm

Fig. 2
 15-151-02-07
 gezahnt
 toothed
 dentadas
 dentelés
 dentate
16 x 5 mm

Fig. 3
 15-151-03-07
 gezahnt
 toothed
 dentadas
 dentelés
 dentate
7 x 4 mm

Fig. 4
 15-151-04-07
 stumpf
 blunt
 romo
 mousse
 smusso
12 x 4 mm

Fig. 5
 15-151-05-07
 sattelförmig
 saddle shaped
 forma de silla
 sous forme de selle
 forma di sella
8 x 4 mm

Fig. 6
 15-151-06-07
 scharf
 sharp
 agudo
 pointu
 acuto
7 x 9 mm

Meyerding
 15-151-01-07 -
 15-151-06-07
 18 cm / 7 1/8"

Wundhäkchen

Hooklets
Ganchitos
Crochetes
Divaricatori

Wundhaken

Retractors
Separadores
carteurs
Divaricatori

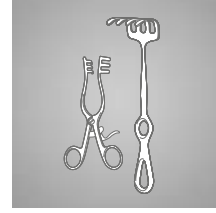

Fig. 1
15-161-01-07
20 x 6 mm



Fig. 2
15-161-02-07
10 x 6 mm



8 x 4,5 mm

15 x 5,5 mm

Ragnell-Davis
15-164-14-07
15 cm / 5 7/8"

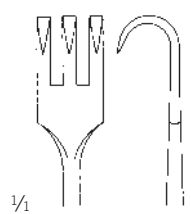

15-166-16-07
scharfe Z hne
sharp prongs
garfios agudos
dents pointus
denti acuti

Bl tter
blades
hojas
lames
lame
20 x 7 mm

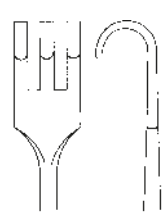

15-167-16-07
stumpfe Z hne
blunt prongs
garfios romos
dents mousses
denti smussi

Bl tter
blades
hojas
lames
lame
20 x 7 mm

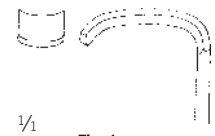

Fig. 1
15-191-01-07
glattes Blattende
smooth blade end
valva lisa
extrémité de la lame lisse
valva liscia

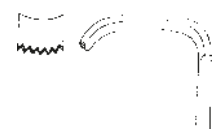

Fig. 2
15-191-02-07
gezahntes Blattende
toothed blade end
vlava dentada
extrémité de la lame dentelé
valva dentada

Senn-Miller
15-166-16-07 -
15-167-16-07
16 cm / 6 2/8"

Strandell-Stille
15-191-01-07 -
15-191-02-07
19 cm / 7 4/8"

Wundhaken

Retractors
Separadores
carteurs
Divaricatori

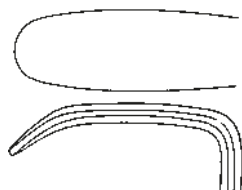

30 x 11 mm
15-293-01-07

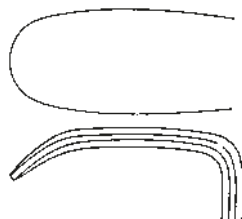

30 x 14 mm
15-293-02-07

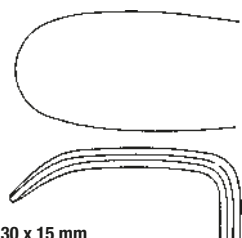

30 x 15 mm
15-293-03-07

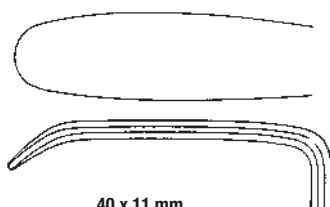

40 x 11 mm
15-293-04-07

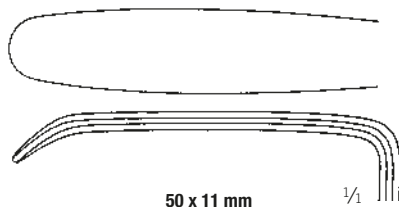

50 x 11 mm
15-293-05-07



6 x 16 mm
15-301-16-07

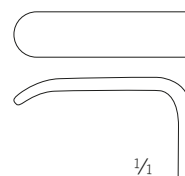

6 x 25 mm
15-301-25-07



1/2

Langenbeck
15-293-01-07 -
15-293-05-07

22 cm / 8 5/8"



1/2

Langenbeck-Green
15-301-16-07 -
15-301-25-07

16 cm / 6 2/8"

Wundhaken

Retractors
Separadores
carteurs
Divaricatori

Wundhaken

Retractors
Separadores
carteurs
Divaricatori

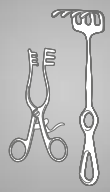

1/2

Kocher-Langenbeck
15-317-01-07 -
15-317-09-07
21,5 cm / 8 5/8"

25 x 6 mm
15-317-01-07

35 x 8 mm
15-317-02-07

35 x 11 mm
15-317-03-07

35 x 15 mm
15-317-04-07

40 x 11 mm
15-317-05-07

55 x 11 mm
15-317-06-07

70 x 14 mm
15-317-07-07

80 x 12 mm
15-317-08-07

80 x 16 mm
15-317-09-07

1/4

15

Wundhaken

Retractors
Separadores
carteurs
Divaricatori



Fig. 1
26 x 10 mm / 30 x 13 mm

Fig. 2
30 x 10 mm / 34 x 13 mm

Farabeuf
15-663-00-07
12 cm / 4 5/8"

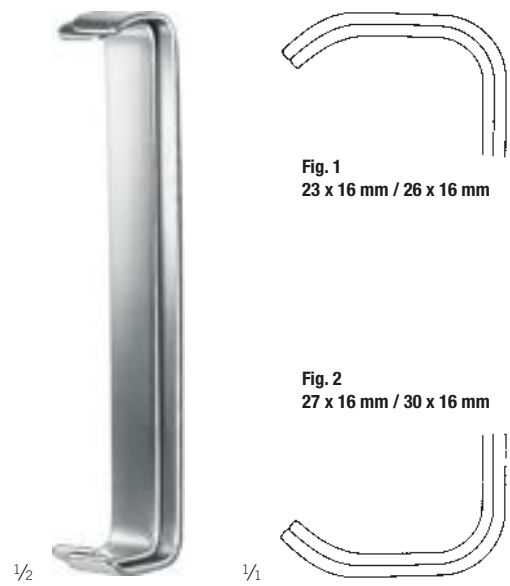

Fig. 1
23 x 16 mm / 26 x 16 mm

Fig. 2
27 x 16 mm / 30 x 16 mm

Farabeuf
15-665-00-07
15,5 cm / 6 1/8"

Wundspreizer, selbsthaltend

Wound Spreaders, self-retaining

Separadores autoestáticos

carteurs autostatiques

Divaricatori autostatici

Wundhaken

Retractors

Separadores

carteurs

Divaricatori



1/2

Finsen

15-700-05-07 -

15-703-07-07

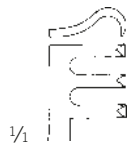

1/4

15-700-05-07

5 cm / 2"

scharf
sharp
agudo
pointu
acuto



2:3



16 mm



15-701-05-07

5 cm / 2"

stumpf
blunt
romo
mousse
smusso



2:3



16 mm

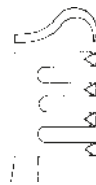

15-702-07-07

7 cm / 2 5/8"

scharf
sharp
agudo
pointu
acuto



3:4



20 mm



15-703-07-07

7 cm / 2 5/8"

stumpf
blunt
romo
mousse
smusso



3:4



20 mm



1/4

15-704-07-07

mit Stellschraube, scharf
with adjusting screw, sharp
con tornillo de ajuste, agudo
avec vis d'ajustage, pointu
con vite di arresto, acuto



3:4



30 mm

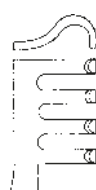

15-705-07-07

mit Stellschraube, stumpf
with adjusting screw, blunt
con tornillo de ajuste, romo
avec vis d'ajustage, mousse
con vite di arresto, smusso



3:4



30 mm



1/2

Finsen-Martin

15-704-07-07 -

15-705-07-07

7,5 cm / 3"

Federspreizer

Spring spreader
Separadores muell.
carteurs ressorts
Divaricatori molli

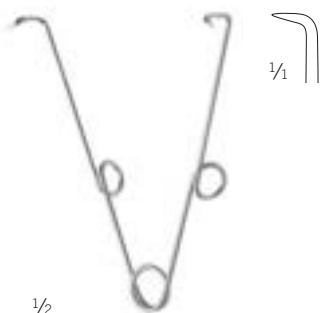

1/2

15-709-00-07

8,5 cm / 3 3/8"

scharf
sharp
agudo
pointu
acuto



1:1

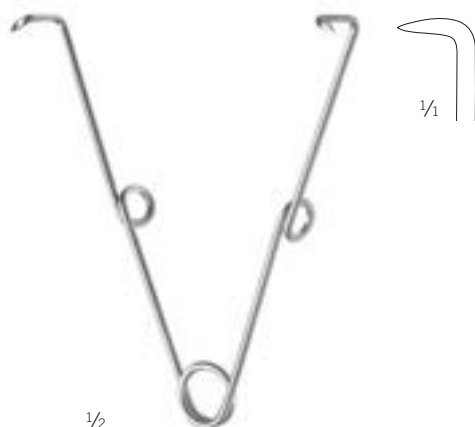

1/2

15-709-01-07

11,5 cm / 4 1/8"

scharf
sharp
agudo
pointu
acuto



1:1

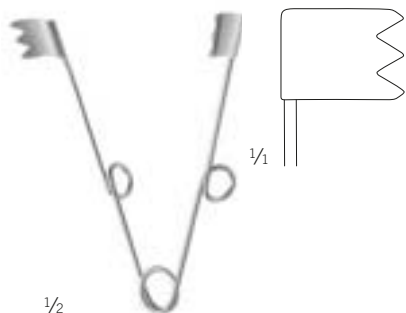

1/2

15-709-02-07

8,5 cm / 3 3/8"

stumpf
blunt
romo
mousse
smusso



3:3

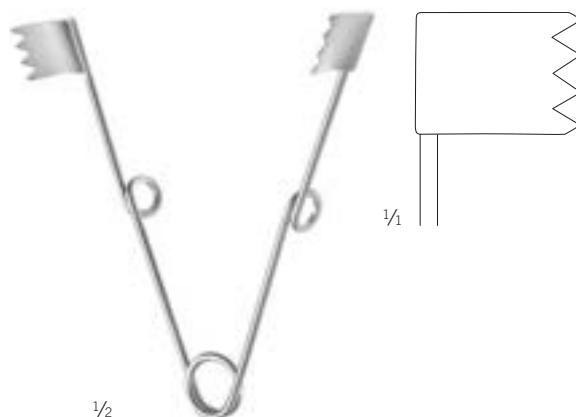

1/2

15-709-03-07

11,5 cm / 4 1/8"

scharf
sharp
agudo
pointu
acuto



4:4



1/2

15-709-04-07

8,5 cm / 3 3/8"

scharf
sharp
agudo
pointu
acuto



1:1

Wundspreizer, selbsthaltend

Wound Spreaders, self-retaining
 Separadores autoestáticos
 carteurs autostatiques
 Divaricatori autostatici

Wundhaken

Retractors
 Separadores
 carteurs
 Divaricatori

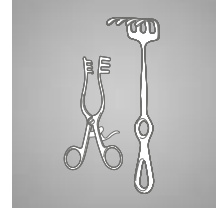

1/2



1/4

15-714-07-07

7 cm / 2 9/8"

scharf
 sharp
 agudo
 pointu
 acuto



4:4



55 mm



15-714-10-07

10 cm / 3 7/8"

scharf
 sharp
 agudo
 pointu
 acuto



4:4



70 mm



15-715-07-07

7 cm / 2 9/8"

stumpf
 blunt
 romo
 mousse
 smusso



4:4



55 mm



15-715-10-07

10 cm / 3 7/8"

stumpf
 blunt
 romo
 mousse
 smusso



4:4



70 mm

Alm

15-714-07-07 -
 15-715-10-07

mit Stellschraube
 with adjusting screw
 con tornillo de ajuste
 avec vis d'ajustage
 con vite di arresto



1/2

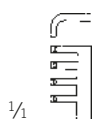

1/4

stumpf
 blunt
 romo
 mousse
 smusso



4:4



24 mm

15-717-10-07

10 cm / 3 7/8"

Wundspreizer, selbsthaltend

Wound Spreaders, self-retaining

Separadores autoestáticos

carteurs autostatiques

Divaricatori autostatici

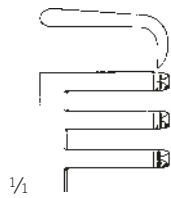

15-748-10-07

halbscharf
semi-sharp
semi-agudo
semi-pointu
semi acuto



2:3



40 mm

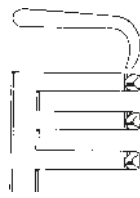

15-749-10-07

stumpf
blunt
romo
mousse
smusso



2:3



40 mm

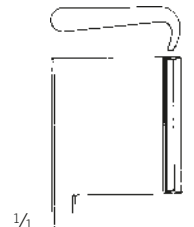

50 mm

1/2

1/2

Weitlaner
15-748-10-07 -
15-749-10-07
11 cm / 4 3/8"

Weitlaner-Baby
15-767-13-07
13,5 cm / 5 3/8"

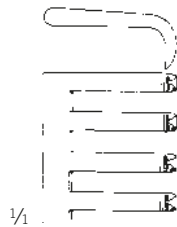

1/2



scharf sharp agudo pointu acuto		15-750-13-07	15-750-16-07
		13,5 cm / 5 3/8"	16 cm / 6 2/8"
		43 mm	83 mm
		3:4	3:4

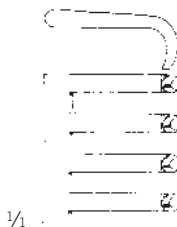

1/2

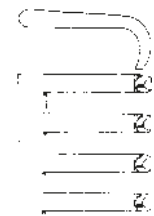

stumpf blunt romo mousse smusso		15-751-13-07	15-751-16-07
		13,5 cm / 5 3/8"	16 cm / 6 2/8"
		43 mm	83 mm
		3:4	3:4

1/2

Weitlaner
15-750-13-07 -
15-751-16-07

Wundspreizer, selbsthaltend

Wound Spreaders, self-retaining
 Separadores autoestáticos
 carteurs autostatiques
 Divaricatori autostatici

Wundhaken

Retractors
 Separadores
 carteurs
 Divaricatori

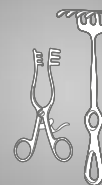

1/2

Low-Profile 15-792-00-01

6 cm / 2 3/8"

komplett, mit Mittelvalve Art.-Nr.
 complete, with central blade ref.
 completo, con valva central ref.
 complet, avec valve centrale réf.
 completo, con valva centrale rif.

15-792-01-01

stumpf
 blunt
 romo
 mousse
 smusso



2:2



25 mm



1/2

Low-Profile 15-793-00-01

9 cm / 3 4/8"

komplett, mit Mittelvalve Art.-Nr.
 complete, with central blade ref.
 completo, con valva central ref.
 complet, avec valve centrale réf.
 completo, con valva centrale rif.

15-792-01-01

stumpf
 blunt
 romo
 mousse
 smusso



3:3



30 mm



1/2

Low-Profile 15-794-00-01

7,5 cm / 3"

komplett, mit Mittelvalve Art.-Nr.
 complete, with central blade ref.
 completo, con valva central ref.
 complet, avec valve centrale réf.
 completo, con valva centrale rif.

15-792-01-01



25 mm



1/2

15-794-90-98

Feder
 Spring
 Pluma
 Piuma



15-794-00-01

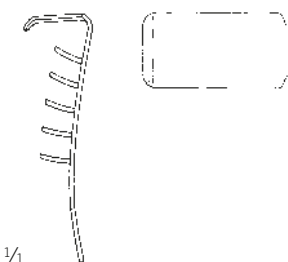

1/1

15-792-01-01

Mittelvalven
 Central Blades
 Valvas centrales
 Valves centrales
 Valve centrali

10 x 18 mm



**15-792-00-01,
 15-793-00-01,
 15-794-00-01,**

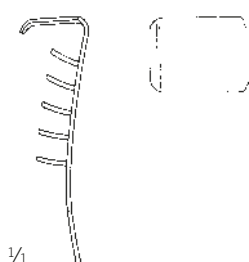

1/1

15-792-02-01

Mittelvalven
 Central Blades
 Valvas centrales
 Valves centrales
 Valve centrali

10 x 12 mm



**15-792-00-01,
 15-793-00-01,
 15-794-00-01,**



1/1

15-798-01-01

5 cm / 3"

stumpf, Ringmodell, für Daumen und Finger
 blunt, ring model, for thumb and fingers
 romo, forma de anillo, para pulgar y dedos
 mousse, mod le anneau, pour pouce et doigts
 smusso, modello anulare, per pollice e le dita

15

Handarthroskopie-System

Hand Arthroscopy System

Ueugger para artroskopia de la mano

Système pour arthroscopie de la main

Sistema per artroskopia della mano



15-910-63-07

Handarthroskopie-Handfessel, sterilisierbar

Hand immobilizer for hand arthroscopy, sterilizable

Inmovilizador de mano para artroskopia de muñeca, esterilizable

Dispositif d'immobilisation pour arthroscopie de la main, stérilisable

Dispositivo di fissaggio mano per artroskopia della mano, sterilizzabile



22-596-01-07 small

22-596-02-07 medium

22-596-03-07 large

Drahtgeflecht, autoklavierbar

Finger extension sleeve, autoclavable

Malla metálica, esterilizable en autoclave

Manchon d'extension de doigt, autoclavable

Maglia metallica, autoclavabile



15-910-62-07

Haltebügel für Fingerextensionshülsen

Horizontal suspension bar for finger extension sleeves

Estrubo de fijación para fundas de tracción digital

Barre de fixation horizontale pour manchons d'extension de doigt

Staffa di sospensione per boccole di estensione delle dita



15-910-52-07

Tischkloben, unisoliert

Fixation clamp, non-insulated

Prensa de fijación, no aislada

Bride de fixation de table, non isolée

Morsetto di fissaggio, non isolato



15-910-61-07

Vertikalstab für horizontale Lagerung

Vertical bar for horizontal placement

Barra vertical para posicionamiento horizontal

Barre verticale pour positionnement horizontal

Barra verticale per posizionamento orizzontale

40 cm



15-910-60-07

Stabverlängerung kurz

Arm extension, short

Barra de extensión, corta

Rallonge courte

Elemento di prolunga corto

50 cm

15-910-60-22

Stabverlängerung lang

Arm extension, long

Barra de extensión, larga

Rallonge longue

Elemento di prolunga lungo

65 cm



15-910-64-07

Handarthroskopie-Vertikalstab mit Kugelgelenk

Vertical bar for hand arthroscopy, with ball joint

Barra vertical con junta de rótula para artroskopia de muñeca

Barre verticale pour arthroscopie de la main avec articulation sphérique

Barra verticale per artroskopia della mano con giunto sferico

46 cm



15-910-59-07

Handarthroskopie-Grundstab

Main support arm for hand arthroscopy

Barra de soporte central para artroskopia de muñeca

Barre de support de base pour arthroscopie de la main

Barra di supporto di base per artroskopia della mano

Ø 16 mm

Handarthroskopie-System

Hand Arthroscopy System
Sistema para artroscopia de la mano
Système pour arthroscopie de la main
Sistema per artroscopia della mano

Wundhaken

Retractors
Separadores
carteurs
Divaricatori



Setvorschläge

Vertikale Lagerung

Art.-Nr.	Systemkomponenten
15-910-03-07	Set komplett, bestehend aus:
15-910-52-07	Tischkloben, unisoliert
15-910-59-07	Grundstab
15-910-60-07	Stabverlängerung
15-910-63-07	Handfessel
15-910-64-07	Vertikalstab mit Kugelgelenk

Horizontale Lagerung

Art.-Nr.	Systemkomponenten
15-910-52-07	Tischkloben, unisoliert
15-910-59-07	Grundstab
15-910-61-07	Vertikalstab
15-910-63-07	Handfessel
15-910-64-07	Vertikalstab mit Kugelgelenk

Recomendaciones de set

Almacenamiento vertical

N.º ref.	Componentes del sistema
15-910-03-07	Set completo compuesto de:
15-910-52-07	Prensa de fijación, no aislada
15-910-59-07	Barra de soporte central
15-910-60-07	Barra de extensión
15-910-63-07	Inmovilizador de mano
15-910-64-07	Barra vertical con junta de rótula

Almacenamiento horizontal

N.º ref.	Componentes del sistema
15-910-52-07	Prensa de fijación, no aislada
15-910-59-07	Barra de soporte central
15-910-61-07	Barra vertical
15-910-63-07	Inmovilizador de mano
15-910-64-07	Barra vertical con junta de rótula

Suggerimenti per le composizioni

Stoccaggio verticale

Codice art.	Componenti del sistema
15-910-03-07	Set completo, composto di:
15-910-52-07	Morsetto di fissaggio, non isolato
15-910-59-07	Barra di supporto di base
15-910-60-07	Elemento di prolunga
15-910-63-07	Dispositivo di fissaggio
15-910-64-07	Barra verticale con giunto sferico

Stoccaggio orizzontale

Codice art.	Componenti del sistema
15-910-52-07	Morsetto di fissaggio, non isolato
15-910-59-07	Barra di supporto di base
15-910-61-07	Barra verticale
15-910-63-07	Dispositivo di fissaggio
15-910-64-07	Barra verticale con giunto sferico

Set recommendations

Vertical positioning

Item No.	System components
15-910-03-07	Set complete consisting of:
15-910-52-07	Fixation clamp, non-insulated
15-910-59-07	Main support arm
15-910-60-07	Arm extension
15-910-63-07	Hand immobilizer
15-910-64-07	Vertical bar with ball joint

Horizontal positioning

Item No.	System components
15-910-52-07	Fixation clamp, non-insulated
15-910-59-07	Main support arm
15-910-61-07	Vertical bar
15-910-63-07	Hand immobilizer
15-910-64-07	Vertical bar with ball joint

Sets recommandés

Stockage vertical

Réf.	Composants du système
15-910-03-07	Set complet, composé de:
15-910-52-07	Bride de fixation de table, non isolée
15-910-59-07	Barre de support de base
15-910-60-07	Rallonge
15-910-63-07	Dispositif d'immobilisation
15-910-64-07	Barre verticale avec articulation sphérique

Stockage horizontal

Réf.	Composants du système
15-910-52-07	Bride de fixation de table, non isolée
15-910-59-07	Barre de support de base
15-910-61-07	Barre verticale
15-910-63-07	Dispositif d'immobilisation
15-910-64-07	Barre verticale avec articulation sphérique

Diagnostik
Diagnostics
Diagnóstico
Diagnostic
Diagnostica

17

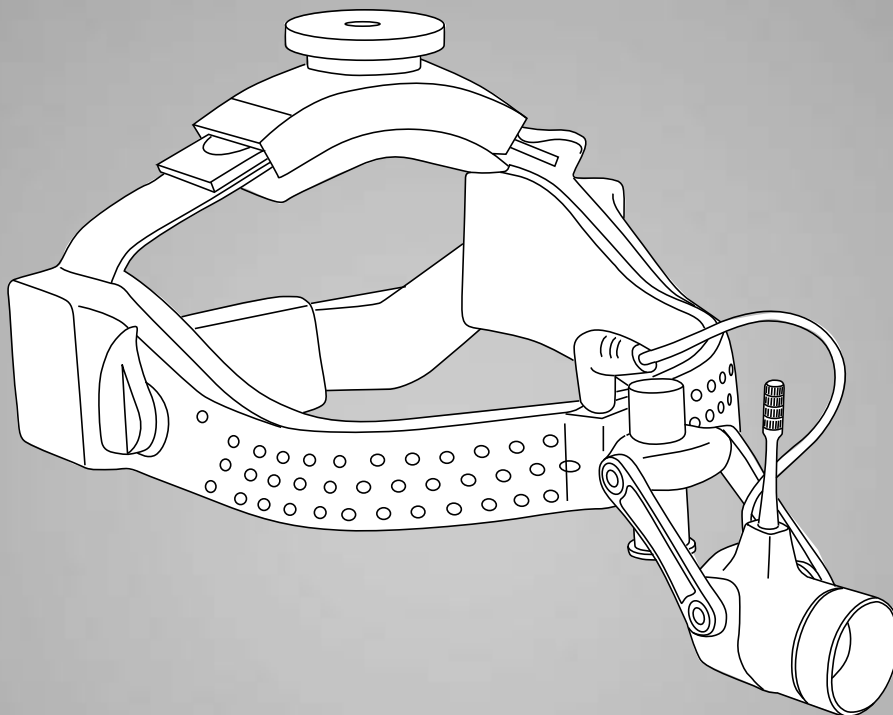

Spezial-Produkte

Special Products

Produits spéciaux

Prodotti speciali

Productos especiales

Informationen zu den KLS-Martin-Stirnleuchten entnehmen Sie bitte der separaten Broschüre „MedLED Chrome“.

Please refer to the separate brochure for information about KLS-Martin headlights “MedLED Chrome”.

Encontrará información sobre las lámparas frontal de KLS-Martin en el folletos individual “MedLED Chrome”.

Veuillez vous reporter au brochure séparée pour obtenir des informations détaillées relatives aux lampes frontales «MedLED Chrome» .

Per informazioni sulle lampada frontale di KLS Martin, consultare le brochure separate KLS Martin “MedLED Chrome”.

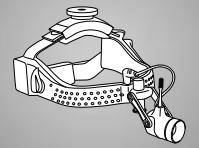

Lineale

Rulers
Reglas
Rgles mesurer
Misuratori



1/2

Carroll
17-408-01-07
14,5 cm / 5 6/8"

Fingergoniometer
Finger Goniometer
Goniómetro para dedos
Goniomètres pour doigts
Goniometro per dita



1/2

17-412-15-07 -
17-412-50-07

Stahlmassstab
Ruler, steel
Regla acero
Rgle de mesure acier
Misuratore acciaio

	17-412-15-07	17-412-20-07	17-412-30-07	17-412-50-07
Bereich ffective range Alcone eficaz Série effectif Rango effective	150 mm / 5 7/8"	200 mm / 7 7/8"	300 mm / 11 7/8"	500 mm / 19 5/8"

18

Sauger, Kanülen
Suction Tubes, Cannulas
Tubos de Aspiración, Cánulas
Tubes d'aspiration, Canules
Tubi d'aspirazione, Cannule

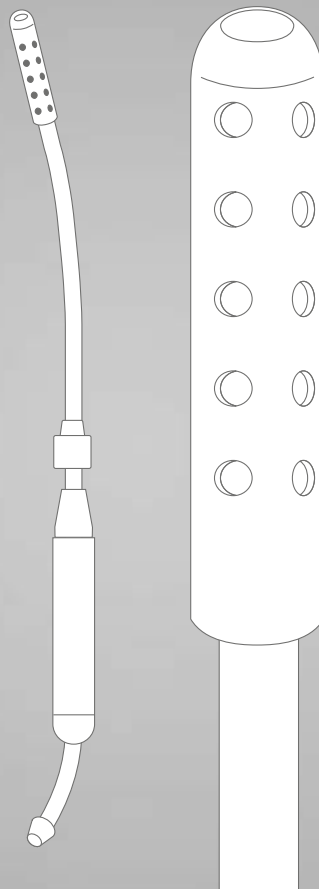

Handgriffe

Handles
Mangos
Manches
Manici



1/2

18-100-00-04

Handgriff, SV, m. Schiebeventil
Handle, FC, w. slide valve
Mango, CR, con válvula deslizante
Poignée, FR, avec soupape
Manico, AR, c/valvola scorrevole



1/2

18-100-01-04

Handgriff, SV, m. Finger Stop
Handle, FC, w. finger stop
Mango, CR, con bloqueo manual
Poignée, FR, avec commande au doigt
Manico, AR, c/Finger Stop



1/2

18-100-02-04

Handgriff, SV, o. Finger Stop
Handle, FC, without. finger stop
Mango, CR, sin bloqueo manual
Poignée, FR, sans commande au doigt
Manico, AR, s/Finger Stop

Handgriffe

Handles
Mangos
Manches
Manici

Sauger, Kanülen

Trocars, Suction Tubes, Cannulas
Trócares, Tubos de Aspiración, Cánulas
Trocarts, Tubes d'aspiration, Canules
Trequarti, Tubi d'aspirazione, Cannule

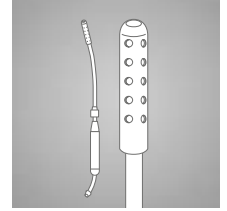

1/2

18-100-03-04

Handgriff, LL, m. Schiebeventil
Handle, LL, w. slide valve
Mango, LL, con válvula deslizante
Poignée, LL, avec soupape
Manico, LL, c/valvola scorrevole



1/2

18-100-04-04

Handgriff, LL, m. Finger Stop
Handle, LL, w. finger stop
Mango, LL, con bloqueo manual
Poignée, LL, avc commande au doigt
Manico, LL, c/Finger Stop



1/2

18-100-05-04

Handgriff, LL, o. Finger Stop
Handle, LL, without. finger stop
Mango, LL, sin bloqueo manual
Poignée, LL, sans commande au doigt
Manico, LL, s/Finger Stop

Kanülen

Cannulas

Cánulas

Canules

Cannule

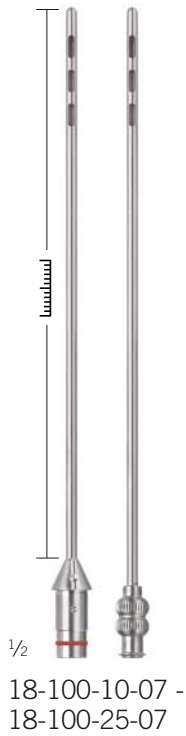

Kanüle, Lipo, Triport Cannula, Lipo, Triport Cánula, Lipo, Triport Canule, lipo, Triport Cannula, lipo, Triport		Fermeture rapide Quick-release fastener Cierre rápido Fermeture rapide Chiusura rapida	Luer-Lock Luer-Lock Luer-Lock Luer-Lock Luer-Lock
Ø	لسلسلا		
1,7 mm	5 cm	18-100-11-07	18-100-10-07
1,7 mm	15 cm	18-100-13-07	18-100-12-07
2,0 mm	5 cm	18-100-15-07	18-100-14-07
2,0 mm	15 cm	18-100-17-07	18-100-16-07
3,0 mm	5 cm	18-100-19-07	18-100-18-07
3,0 mm	15 cm	18-100-21-07	18-100-20-07
3,0 mm	20 cm	18-100-23-07	18-100-22-07
3,0 mm	30 cm	18-100-25-07	18-100-24-07

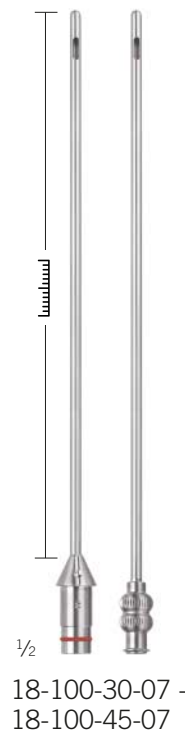

Kanüle, Lipo, Monoport Cannula, Lipo, Monoport Cánula, Lipo, Monoport Canule, lipo, monoport Cannula, lipo, Monoport		Fermeture rapide Quick-release fastener Cierre rápido Fermeture rapide Chiusura rapida	Luer-Lock Luer-Lock Luer-Lock Luer-Lock Luer-Lock
Ø	لسلسلا		
1,7 mm	5 cm	18-100-31-07	18-100-30-07
1,7 mm	15 cm	18-100-33-07	18-100-32-07
2,0 mm	5 cm	18-100-35-07	18-100-34-07
2,0 mm	15 cm	18-100-37-07	18-100-36-07
3,0 mm	5 cm	18-100-39-07	18-100-38-07
3,0 mm	15 cm	18-100-41-07	18-100-40-07
3,0 mm	20 cm	18-100-43-07	18-100-42-07
3,0 mm	30 cm	18-100-45-07	18-100-44-07

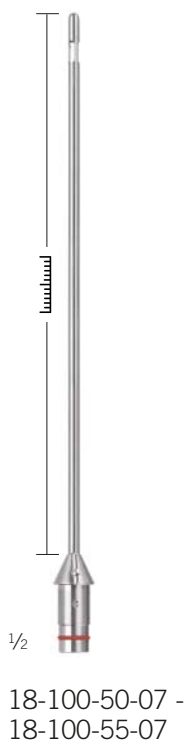

Kanüle, Lipo, Mercedes Cannula, Lipo, Mercedes Cánula, Lipo, Mercedes Canule, Lipo, Mercedes Cannula, Lipo, Mercedes		Fermeture rapide Quick-release fastener Cierre rápido Fermeture rapide Chiusura rapida
Ø	لسلسلا	
3,0 mm	15 cm	18-100-50-07
3,0 mm	20 cm	18-100-51-07
3,0 mm	25 cm	18-100-52-07
4,0 mm	15 cm	18-100-53-07
4,0 mm	20 cm	18-100-54-07
4,0 mm	25 cm	18-100-55-07

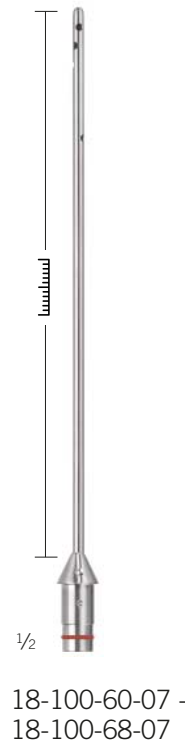

Kanüle, Lipo, Spirale Cannula, Lipo, spirale Cánula, Lipo, spirale Canule, lipo, spirale Cannula, lipo, spirale		Fermeture rapide Quick-release fastener Cierre rápido Fermeture rapide Chiusura rapida
Ø	لسلسلا	
3,0 mm	20 cm	18-100-60-07
3,0 mm	30 cm	18-100-61-07
4,0 mm	20 cm	18-100-62-07
4,0 mm	30 cm	18-100-63-07
4,0 mm	40 cm	18-100-64-07
5,0 mm	30 cm	18-100-65-07
5,0 mm	40 cm	18-100-66-07
6,0 mm	30 cm	18-100-67-07
6,0 mm	40 cm	18-100-68-07

Kanülen

Cannulas
Cánulas
Canules
Cannule

Sauger, Kanülen

Trocars, Suction Tubes, Cannulas
Trócares, Tubos de Aspiración, Cánulas
Trocart, Tubes d'aspiration, Canules
Trequarti, Tubi d'aspirazione, Cannule

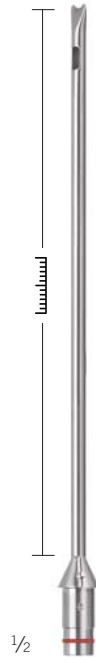
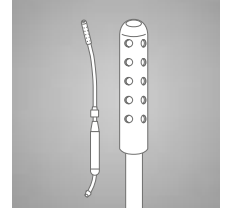

18-100-70-07 -
18-100-81-07

Kanüle, Lipo, Shark Cannula, Lipo, Shark Cánula, Lipo, Shark Canule, Lipo, Shark Cannula, Lipo, Shark		Fermeture rapide Quick-release fastener Cierre rápido Fermeture rapide Chiusura rapida
Ø	سلسلسا	
2,0 mm	5 cm	18-100-70-07
2,0 mm	15 cm	18-100-71-07
3,0 mm	5 cm	18-100-72-07
3,0 mm	15 cm	18-100-73-07
3,0 mm	25 cm	18-100-74-07
3,0 mm	30 cm	18-100-75-07
4,0 mm	5 cm	18-100-76-07
4,0 mm	15 cm	18-100-77-07
4,0 mm	25 cm	18-100-78-07
4,0 mm	30 cm	18-100-79-07
5,0 mm	30 cm	18-100-80-07
6,0 mm	30 cm	18-100-81-07

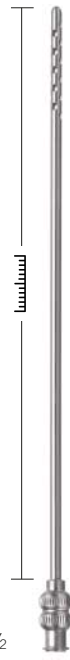

18-100-90-07 -
18-100-91-07

Kanüle, Infiltration, 22 Löcher Cannula, infiltration, 22 holes Cánula, infiltración, 22 orificios Canule, infiltration, 22 trous Cannula, infiltrazione, 22 fori		Luer-Lock, gerade Luer-Lock, straight Luer-Lock, recta Luer-Lock, droite Luer-Lock, diritto
Ø	سلسلسا	
3,0 mm	20 cm	18-100-90-07
4,0 mm	20 cm	18-100-91-07

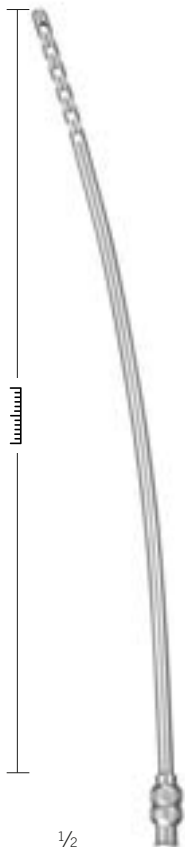

18-100-92-07 -
18-100-93-07

Kanüle, Infiltration, 22 Löcher Cannula, infiltration, 22 holes Cánula, infiltración, 22 orificios Canule, infiltration, 22 trous Cannula, infiltrazione, 22 fori		Luer-Lock, gebogen Luer-Lock, curved Luer-Lock, curva Luer-Lock, courbe Luer-Lock, courbe
Ø	سلسلسا	
3,0 mm	20 cm	18-100-92-07
4,0 mm	20 cm	18-100-93-07

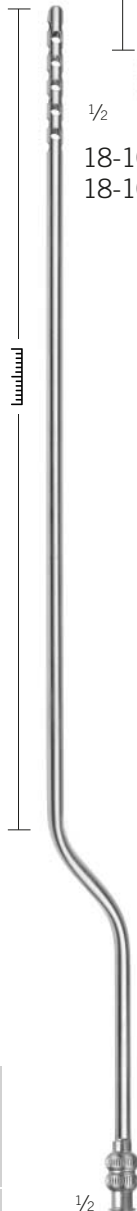

18-100-94-07 -
18-100-95-07

Kanüle, Infiltration, 22 Löcher Cannula, infiltration, 22 holes Cánula, infiltración, 22 orificios Canule, infiltration, 22 trous Cannula, infiltrazione, 22 fori		Luer-Lock, bajonett Luer-Lock, bayonet Luer-Lock, bayoneta Luer-Lock, baionnette Luer-Lock, baionetta
Ø	سلسلسا	
3,0 mm	20 cm	18-100-94-07
4,0 mm	20 cm	18-100-95-07

18

Kanülen

Cannulas

Cánulas

Canules

Cannule



Kanüle, Lipo, Monoport Cannula, Lipo, Monoport Cánula, Lipo, Monoport Canule, Lipo, Monoport Cannula, Lipo, Monoport		fester Griff, gerade fixed handle, straight fester Griff, recta manche ferme, droit impugnatura rigida, diritta
Ø	للسلسا	
3,0 mm	15 cm	18-110-10-07
3,0 mm	25 cm	18-110-11-07
4,0 mm	15 cm	18-110-12-07
4,0 mm	25 cm	18-110-13-07
6,0 mm	15 cm	18-110-14-07
6,0 mm	25 cm	18-110-15-07
9,0 mm	30 cm	18-110-16-07



Kanüle, Lipo, Monoport Cannula, Lipo, Monoport Cánula, Lipo, Monoport Canule, Lipo, Monoport Cannula, Lipo, Monoport		fester Griff, gebogen fixed handle, curved fester Griff, curva manche ferme, courbe impugnatura rigida, curva
Ø	للسلسا	
3,0 mm	15 cm	18-110-17-07
3,0 mm	25 cm	18-110-18-07
6,0 mm	15 cm	18-110-19-07
6,0 mm	25 cm	18-110-20-07

Kanüle, Lipo, Triport Cannula, Lipo, Triport Cánula, Lipo, Triport Canule, lipo, triport Cannula, Lipo, Triport		fester Griff fixed handle fester Griff manche ferme impugnatura rigida
Ø	للسلسا	
4,0 mm	15 cm	18-110-30-07
4,0 mm	25 cm	18-110-31-07
6,0 mm	25 cm	18-110-32-07
6,0 mm	30 cm	18-110-33-07

1/2

18-110-10-07 -
18-110-20-07

1/2

18-110-30-07 -
18-110-33-07



1/2

28-120-00-07

7,5 cm / 3"

Transferadapter, LLW zu LLW, 7,5 cm
Adapter, LLW to LLW, 7,5 cm
Adaptador transf., LL/F p. LL/F; 7,5 cm
Adapt. transfert, LL/F vers LL/F, 7,5 cm
Adattat.trasfer., LL/F a LL/F, 7,5 cm

Naht
Suture
Sutura
Suture
Sutura

20

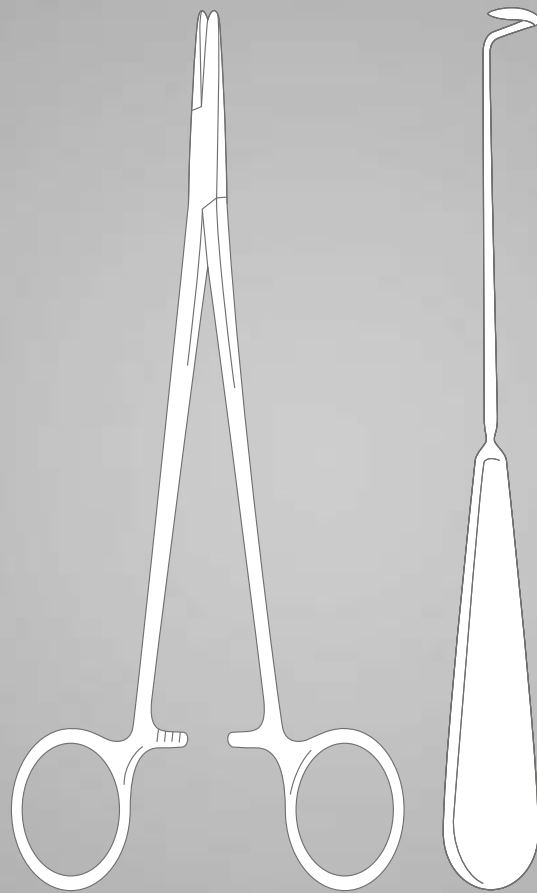

Mikro-Nadelhalter

Micro Needle Holders

Micro Porta-agujas

Micro porte-aiguilles

Micro Portaghi



8-0 - 9-0

1₁



		mit Sperre with lock con trinquete avec cran d'arr t con arresto	mit Sperre with lock con trinquete avec cran d'arr t con arresto	ohne Sperre without lock sin trinquete sans cran d'arr t senza arresto	ohne Sperre without lock sin trinquete sans cran d'arr t senza arresto
	Ø	0.40 mm	0.40 mm	0.40 mm	0.40 mm
15 cm / 5 7/8"	St	20-002-15-07	20-003-15-07	20-004-15-07	20-005-15-07
	Ti	20-016-15-09	20-017-15-09	20-018-15-09	20-019-15-09
18 cm / 7 1/8"	St	20-002-18-07	20-003-18-07	20-004-18-07	20-005-18-07
	Ti	20-016-18-09	20-017-18-09	20-018-18-09	20-019-18-09

1₂

20-002-15-07 -
20-019-18-09



6-0 - 8-0

1₁



		mit Sperre with lock con trinquete avec cran d'arr t con arresto	mit Sperre with lock con trinquete avec cran d'arr t con arresto	ohne Sperre without lock sin trinquete sans cran d'arr t senza arresto	ohne Sperre without lock sin trinquete sans cran d'arr t senza arresto
	Ø	0.80 mm	0.80 mm	0.80 mm	0.80 mm
15 cm / 5 7/8"	St	20-010-15-07	20-011-15-07	20-012-15-07	20-013-15-07
	Ti	20-020-15-09	20-021-15-09	20-022-15-09	20-023-15-09
18 cm / 7 1/8"	St	20-010-18-07	20-011-18-07	20-012-18-07	20-013-18-07
	Ti	20-020-18-09	20-021-18-09	20-022-18-09	20-023-18-09
21 cm / 8 2/8"	St	20-010-21-07	20-011-21-07	20-012-21-07	20-013-21-07
	Ti	20-020-21-09	20-021-21-09	20-022-21-09	20-023-21-09
23 cm / 9"	St	20-010-23-07	20-011-23-07	20-012-23-07	20-013-23-07
	Ti	20-020-23-09	20-021-23-09	20-022-23-09	20-023-23-09

1₂

20-010-15-07 -
20-023-23-09

Mikro-Nadelhalter

Micro Needle Holders
 Micro Porta-agujas
 Micro porte-aiguilles
 Micro Portaghi

Naht
 Sutura
 Sutura
 Suture
 Sutura

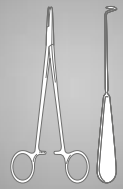

5-0 – 7-0

1 1



1 2

		mit Sperre with lock con trinquete avec cran d'arr t con arresto	mit Sperre with lock con trinquete avec cran d'arr t con arresto	ohne Sperre without lock sin trinquete sans cran d'arr t senza arresto	ohne Sperre without lock sin trinquete sans cran d'arr t senza arresto
	Ø	1.2 mm	1.2 mm	1.2 mm	1.2 mm
15 cm / 5 7/8"	St	20-030-15-07	20-031-15-07	20-032-15-07	20-033-15-07
	Ti	20-030-15-09	20-031-15-09	20-032-15-09	20-033-15-09
18 cm / 7 1/8"	St	20-030-18-07	20-031-18-07	20-032-18-07	20-033-18-07
	Ti	20-030-18-09	20-031-18-09	20-032-18-09	20-033-18-09
21 cm / 8 2/8"	St	20-030-21-07	20-031-21-07	20-032-21-07	20-033-21-07
	Ti	20-030-21-09	20-031-21-09	20-032-21-09	20-033-21-09
23 cm / 9"	St	20-030-23-07	20-031-23-07	20-032-23-07	20-033-23-07
	Ti	20-030-23-09	20-031-23-09	20-032-23-09	20-033-23-09

20-030-15-07 -
 20-033-23-09

20

Mikro-Nadelhalter

Micro Needle Holders

Micro Porta-agujas

Micro porte-aiguilles

Micro Portaghi



		mit Sperre with lock con trinquete avec cran d'arr t con arresto	mit Sperre with lock con trinquete avec cran d'arr t con arresto	ohne Sperre without lock sin trinquete sans cran d'arr t senza arresto	ohne Sperre without lock sin trinquete sans cran d'arr t senza arresto
18 cm / 7 1/8"	St	20-048-18-07	20-049-18-07	20-050-18-07	20-051-18-07

20-048-18-07 -
20-051-18-07
18 cm / 7 1/8"



	20-298-10-07 10,5 cm / 4 1/8"	20-298-11-07 11,5 cm / 4 4/8"
	20-299-10-07 10,5 cm / 4 1/8"	20-299-11-07 11,5 cm / 4 4/8"

Barraquer-Troutman
20-298-10-07 -
20-299-11-07

Mikro-Nadelhalter

Micro Needle Holders

Micro Porta-agujas

Micro porte-aiguilles

Micro Portaghi

Naht

Suture

Sutura

Suture

Sutura

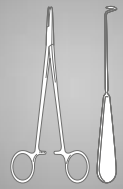

1₂

1₁



		ohne Sperre without lock sin trinquete sans cran d'arr t senza arresto	ohne Sperre without lock sin trinquete sans cran d'arr t senza arresto	mit Sperre with lock con trinquete avec cran d'arr t con arresto
11,5 cm / 4 1/8"	St	20-300-11-07		
13,5 cm / 5 3/8"	St		20-300-13-07	20-300-14-07

Barraquer
20-300-11-07 -
20-300-14-07

20



1₂

Barraquer
20-301-13-07

13,5 cm / 5 3/8"

sehr feines Maul
very delicate jaw
boca muy delicada
mors tr s fin
morso strafino



1₂

Castroviejo-Fino
20-302-01-07

13 cm / 5 1/8"

sehr feines Maul
very delicate jaw
boca muy delicada
mors tr s fin
morso strafino



1₂

Castroviejo-Fino
20-303-09-07

9 cm / 3 4/8"



1₂

Castroviejo-Fino
20-304-09-07

9 cm / 3 4/8"



1₂

Castroviejo-Fino
20-305-09-07

9 cm / 3 4/8"

Mikro-Nadelhalter

Micro Needle Holders

Micro Porta-agujas

Micro porte-aiguilles

Micro Portaghi



20-306-14-07
14,5 cm / 5 6/8"



20-307-14-07
14,5 cm / 5 6/8"



20-308-14-07
14,5 cm / 5 6/8"



20-309-14-07
14,5 cm / 5 6/8"

Castroviejo
20-306-14-07 -
20-307-14-07

Castroviejo
20-308-14-07 -
20-309-14-07



20-310-14-07
14,5 cm / 5 6/8"



20-311-14-07
14,5 cm / 5 6/8"



Castroviejo
20-310-14-07 -
20-311-14-07

Castroviejo
20-313-14-07
14,5 cm / 5 6/8"

Mikro-Nadelhalter, Nadelhalter

Micro Needle Holders, Needle Holders

Micro Porta-agujas, Porta-agujas

Micro porte-aiguilles, Porte-aiguilles

Micro Portaghi, Portaghi

Naht

Suture

Sutura

Suture

Sutura



20-328-12-07

13 cm / 5 1/8"

längsgerieftes Maul

jaw with longitudinal serration

boca con estrías longitudinales

mors avec rainures longitudinales

morso con strie longitudinali

Derf

20-328-12-07

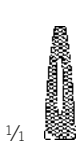

Collier

20-332-12-07

12,5 cm / 4 7/8"

beide Maulteile durchgehend gefenestert

both jaws totally fenestrated

ambas mordazas completamente fenestradas

les deux mors fenestrés sur toute leur longueur

entrambe le gole completamente a finestra



Neivert

20-338-13-07

12,5 cm / 4 7/8"

glattes Maul mit Spezialkehlung

smooth jaw, special groove

boca lisa, especialmente acanalada

mors lisse, avec stries spéciales

morso liscio con scannellatura speciale

Nadelhalter

Needle Holders

Porta-agujas

Porte-aiguilles

Portaghi



1/2

1/1



20-390-14-07
14,5 cm / 5 7/8"



20-390-18-07
18,5 cm / 7 2/8"



20-390-20-07
20,5 cm / 8 1/8"



20-390-24-07
24 cm / 9 4/8"

Mayo-Hegar
20-390-14-07 -
20-390-24-07



1/2

1/1



20-396-16-07
16 cm / 6 2/8"

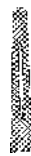

20-396-18-07
19 cm / 7 4/8"



20-396-20-07
20,5 cm / 8 1/8"

Mayo-Hegar
20-396-16-07 -
20-396-20-07

schlankes Modell
slender pattern
modelo delgado
mod le gracile
modello delicato



1/2

1/1

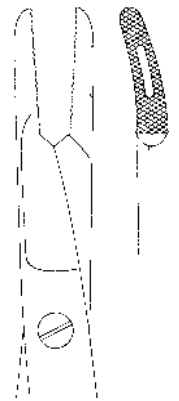

Gillies
20-469-16-07
16 cm / 6 2/8"

Mikro-Nadelhalter, Nadelhalter

Micro Needle Holders, Needle Holders

Micro Porta-agujas, Porta-agujas

Micro porte-aiguilles, Porte-aiguilles

Micro Portaghi, Portaghi

Naht

Suture

Sutura

Suture

Sutura

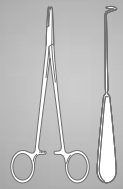

TC GOLD

- 6-0 - 12-0
- Smooth



Webster
20-604-13-07
13 cm 5 1/8"

Crile-Wood
20-604-15-07
15 cm 5 7/8"

- 4-0 - 6-0
- Mini

mit Durchdrücksperr e auch für Linksh nder geeignet
with automatic release ratchet also for lefthanders
con cremallera automática también para zurdos
avec cremail l re automatique aussi pour gauchers
con cremagliera automatica anche per mancini

Hepp-Scheidel
20-602-18-07
18,5 cm / 7 3/8"

20-604-13-07 -
20-604-15-07

20



- 2-0 - 4-0



		mit Sperre with lock con trinquete avec cran d'arr t con arresto	mit Sperre with lock con trinquete avec cran d'arr t con arresto	ohne Sperre without lock sin trinquete sans cran d'arr t senza arresto	ohne Sperre without lock sin trinquete sans cran d'arr t senza arresto
	Ø	2.0 mm	2.0 mm	2.0 mm	2.0 mm
15 cm / 5 7/8"	St	20-606-15-07	20-605-15-07	20-608-15-07	20-607-15-07
18 cm / 7 1/8"	St	20-606-18-07	20-605-18-07	20-608-18-07	20-607-18-07
21 cm / 8 2/8"	St	20-606-21-07	20-605-21-07	20-608-21-07	20-607-21-07
23 cm / 9"	St	20-606-23-07	20-605-23-07	20-608-23-07	20-607-23-07

20-605-15-07 -
20-608-23-07

Mikro-Nadelhalter, Nadelhalter

Micro Needle Holders, Needle Holders

Micro Porta-agujas, Porta-agujas

Micro porte-aiguilles, Porte-aiguilles

Micro Portaghi, Portaghi

TC GOLD



2-0 - 5-0



diamond-coated



safety-wave



1/1



5-0 - 8-0

Micro

1/2

aboma
20-610-18-07
18 cm / 7 1/8"



1/2

Heavy Duty
20-613-19-07 -
20-613-23-07

1/1



20-613-19-07
19 cm / 7 4/8"



20-613-23-07
23 cm / 9"

Kurze Mikro-Nadelhalter

Short Micro Needle Holders

Micro Porta-agujas, corto

Micro porte-aiguilles, court

Micro Portaghi, corto

Naht

Suture

Sutura

Suture

Sutura

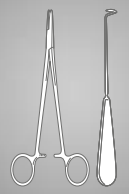

1/2



safety-wave



diamond-coated



8-0 - 9-0

1 1



		mit Sperre with lock con trinquete avec cran d'arr t con arresto	mit Sperre with lock con trinquete avec cran d'arr t con arresto	ohne Sperre without lock sin trinquete sans cran d'arr t senza arresto	ohne Sperre without lock sin trinquete sans cran d'arr t senza arresto
∅		0.40 mm	0.40 mm	0.40 mm	0.40 mm
St		20-614-02-07	20-615-01-07	20-614-01-07	20-615-02-07

20-614-01-07 -
20-615-02-07

14,5 cm / 5 7/8"

20



1/2



safety-wave



diamond-coated



8-0 - 9-0

1 1



		mit Sperre with lock con trinquete avec cran d'arr t con arresto	ohne Sperre without lock sin trinquete sans cran d'arr t senza arresto	ohne Sperre without lock sin trinquete sans cran d'arr t senza arresto	mit Sperre with lock con trinquete avec cran d'arr t con arresto
∅		0.40 mm	0.40 mm	0.40 mm	0.40 mm
St		20-614-04-07	20-615-04-07	20-614-03-07	20-615-03-07

20-614-03-07 -
20-615-04-07

14,5 cm / 5 7/8"

Mikro-Nadelhalter

Micro Needle Holders

Micro Porta-agujas

Micro porte-aiguilles

Micro Portaghi

TC GOLD



1 1

20-620-00-07

14,5 cm / 5 7/8"



20-620-01-07

14,5 cm / 5 7/8"



20-620-14-07

14,5 cm / 5 7/8"



20-620-18-07

18 cm / 7 1/8"



1 1

20-620-21-07

22 cm / 8 5/8"



20-621-14-07

14,5 cm / 5 7/8"



20-621-18-07

18 cm / 7 1/8"



20-621-21-07

22 cm / 8 5/8"



Castroviejo
20-620-00-07 -
20-621-21-07



1/1



1/1

20-636-13-07

13 cm 5 1/8"



20-637-13-07

13 cm 5 1/8"



Derf
20-632-12-07
12 cm / 4 5/8"

Halsey
20-636-13-07 -
20-637-13-07

Mikro-Nadelhalter

Micro Needle Holders
 Micro Porta-agujas
 Micro porte-aiguilles
 Micro Portaghi

Naht

Suture
 Sutura
 Sutura
 Sutura

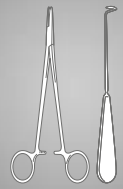

TC GOLD



Crile-Wood
 20-638-20-07
 20,5 cm / 8 1/8"

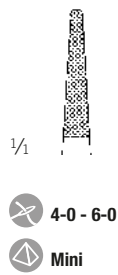

Mayo-Hegar
 20-642-16-07 -
 20-642-30-07



20-642-16-07
 16 cm / 6 2/8"

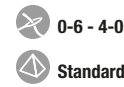

20-642-18-07
 18,5 cm / 7 2/8"

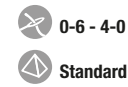

20-642-20-07
 20 cm / 7 7/8"



20-642-24-07
 24 cm / 9 4/8"



20-642-26-07
 26,5 cm / 10 3/8"



20-642-30-07
 30 cm / 11 5/8"



20

Nadelhalter

Needle Holders

Porta-agujas

Porte-aiguilles

Portaghi

TC GOLD

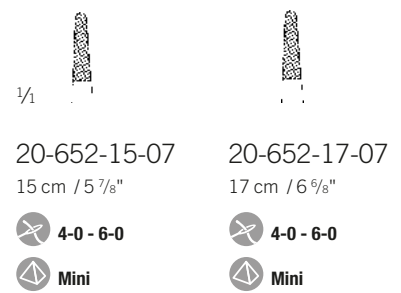
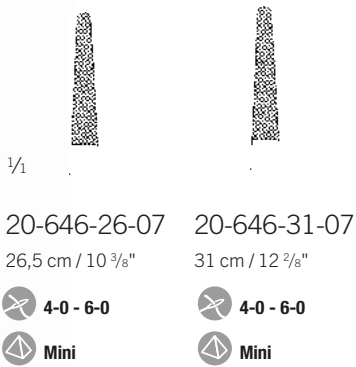
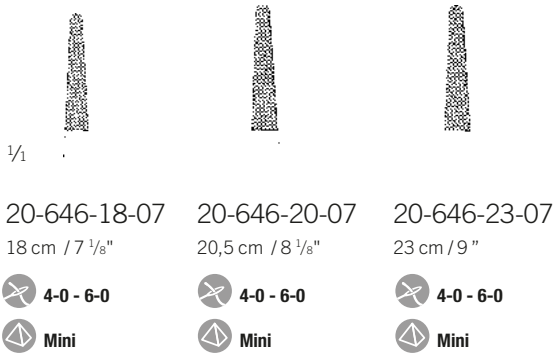

DeBakey
20-646-18-07 -
20-646-31-07

schlankes Modell
slender pattern
modelo delgado
mod le gracile
modello delicato

Martin
20-652-15-07 -
20-652-17-07

elastisches Modell
elastic tip
modelo elástico
mod le souple
modello molle

Nadelhalter

Needle Holders
Porta-agujas
Porte-aiguilles
Portaghi

Naht

Sutura
Sutura
Suture
Sutura

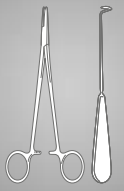

TC GOLD



Bozemann
20-659-20-07 -
20-659-28-07



20-659-20-07

20,5 cm / 8 1/8"



Standard



20-659-24-07

24 cm / 9 1/8"



Standard



20-659-26-07

26 cm / 10 1/8"



Standard



20-659-28-07

30 cm / 11 5/8"



Standard



Microvascular
20-666-05-07
26 cm / 10 3/8"



Micro

20

Nadelhalter, Mikro-Nadelhalter

Needle Holders, Micro Needle Holders

Porta-agujas, Micro Porta-agujas

Porte-aiguilles, Micro porte-aiguilles

Portaghi, Micro Portaghi

TC GOLD

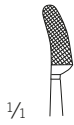

4-0 - 6-0

Mini

Gillies-Mini
20-673-15-07
15 cm / 5 7/8"



0-6 - 4-0

Standard

Gillies
20-673-16-07
16 cm / 6 2/8"

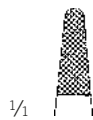

20-676-14-07
14 cm / 5 4/8"

0-6 - 4-0

Standard



20-676-17-07
17 cm / 6 6/8"

0-6 - 4-0

Standard



20-676-20-07
20 cm / 7 7/8"

0-6 - 4-0

Standard

Mathieu
20-676-14-07 -
20-676-20-07



1 1

24-851-10-07
20 cm / 7 7/8"



24-851-11-07
20 cm / 7 7/8"



24-851-12-07
22,5 cm / 8 7/8"



24-851-13-07
22,5 cm / 8 7/8"

1 2

asargil
24-851-10-07 -
24-851-13-07

Knochenchirurgie
Bone Surgery
Cirugía ósea
Chirurgie osseuse
Chirurgia ossea

22-23

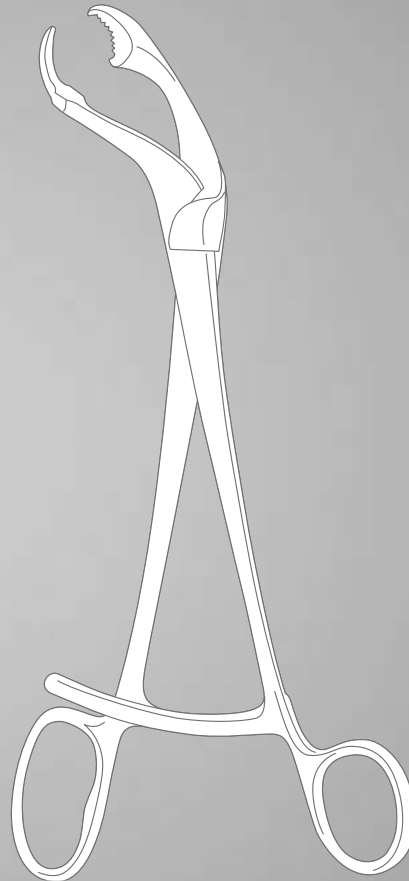
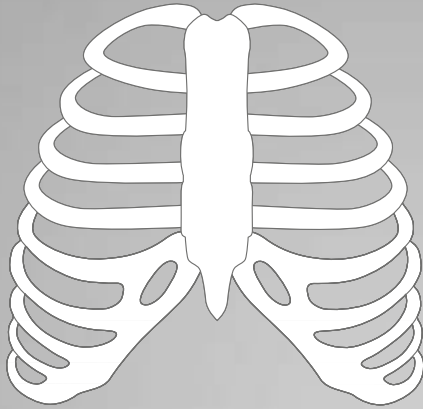

Drahtwirbelzangen, Flachzangen

Wire Twisting Forceps, Flat Nose Pliers

Pinzas para torcer alambre, Alicates de pico plano

Pinces torsader le fil, Pinces plates

Pinze per ritorcere fili, Tenaglie piatte

TC GOLD



22-500-15-07

15,5 cm / 6 1/8"



22-500-20-07

20 cm / 7 7/8"



22-511-01-07

18 cm / 7 1/8"

parallel fassend
parallel grip
acción paralela
action parallèle
afferamento parallelo



Hackstock

22-518-16-07

16 cm / 6 3/8"

mit Längsrille
with longitudinal groove
con ranura longitudinal
avec rainure longitudinale
con scannellatura longitudinale



Martin Diamant

22-522-16-07

16 cm / 6 3/8"

Kopfschneider
Wire Cutter, front action
Alicate frontal para cortar alambre
Pinces coupantes frontales
Tenaglie tagliafilii frontali

Schnittbreite
Cutting width
Ancho de cortar
Largeur de coupe
Ampiezza di taglio
14,5 mm

für weiche Drähte bis
for soft wires up to
para alambres blandos hasta
pour fils mous jusqu'
per fili molli fino a
Ø 2,2 mm

für harte Drähte bis
for hard wires up to
para alambres duros hasta
pour fils durs jusqu'
per fili metallici duri fino a
Ø 2,0 mm

Seitenschneider

Wire Cutting Pliers
Tenazas de corte lateral
Pincers coupantes de côté
Tenaglie tagliafili laterali

Knochenchirurgie

Bone Surgery
Cirugía ósea
Chirurgie osseuse
Chirurgia ossea

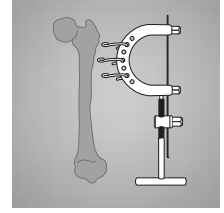

TC GOLD



1/2



1/1

für weiche Dr hte bis
for soft wires up to
para alambres blandos hasta
pour fils mous jusqu
per fili molli fino a
Ø 2,0 mm

für harte Dr hte bis
for hard wires up to
para alambres duros hasta
pour fils durs jusqu
per fili metallici duri fino a
Ø 1,7 mm

22-523-16-07

17 cm / 6 5/8"



1/2

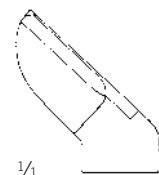

1/1

für weiche Dr hte bis
for soft wires up to
para alambres blandos hasta
pour fils mous jusqu
per fili molli fino a
Ø 2,8 mm

für harte Dr hte bis
for hard wires up to
para alambres duros hasta
pour fils durs jusqu
per fili metallici duri fino a
Ø 2,2 mm

22-523-22-07

23 cm / 9"



1/2

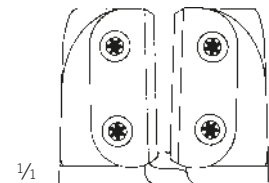

1/1

für weiche Dr hte bis
for soft wires up to
para alambres blandos hasta
pour fils mous jusqu
per fili molli fino a
Ø 2,8 mm

für harte Dr hte bis
for hard wires up to
para alambres duros hasta
pour fils durs jusqu
per fili metallici duri fino a
Ø 2,2 mm

22-523-81-98

rsatzteil-Set
Spare part set
uego de pieza de repuesto
Set de pi ce détachée
Set di pezzo di ricambio

22-523-25-07

21,5 cm / 8 1/2"

22
23

Seitenschneider, Stahldraht

Wire Cutting Pliers, Bone Wire

Tenazas de corte laterale, Alambre para hueso

Pinces coupantes de côté, Fil d'os

Tenaglie tagliafili laterali, Filo per ossa

TC GOLD

Schnittbreite
Cutting width
Ancho de cortar
Largeur de coupe
Ampiezza di taglio
18 mm

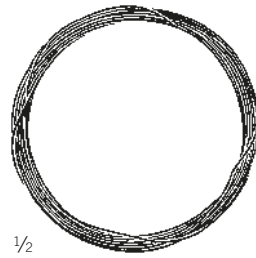
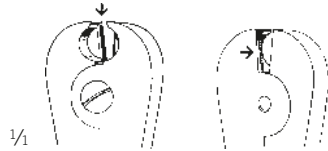

22-527-02-05 - 22-527-15-05

weich, Rolle mit 10 m
soft, coil of 10 m
blando, rollo de 10 m
malléable, en rouleaux de 10 m
malleabile, rotolo di 10 m

Ø	
0,2 mm	22-527-02-05
0,3 mm	22-527-03-05
0,4 mm	22-527-04-05
0,5 mm	22-527-05-05
0,6 mm	22-527-06-05
0,7 mm	22-527-07-05
0,8 mm	22-527-08-05
0,9 mm	22-527-09-05
1,0 mm	22-527-10-05
1,2 mm	22-527-12-05
1,5 mm	22-527-15-05



für weiche Drähte bis
for soft wires up to
para alambres blandos hasta
pour fils mous jusqu'
per fili molli fino a
Ø 2,0 mm

für harte Drähte bis
for hard wires up to
para alambres duros hasta
pour fils durs jusqu'
per fili metallici duri fino a
Ø 1,5 mm

22-526-18-07

17,5 cm / 6 7/8"

Kopf- u. Seitenschneider
Wire Cutting Pliers
Alicates para cortar alambre
Pince pour couper le fil
Tenaglia tagliafili



22-596-01-07	klein small pequeño petit piccolo
22-596-02-07	mittel medium mediano moyen mezzo
22-596-03-07	groß large grande grand grande

22-618-90-98



zur Einbringung und Extraktion von K-Drähten
for insertion and extraction of K-wires
para la inserción y extracción de alambres
pour insertion et extraction des fils
per inserimento e rimozione dei fili
Ø 0,8 - 1,6 mm

asidriver
22-618-00-07

14 cm / 5 1/2"

Drahtgeflecht, autoklavierbar
wire mesh, autoclavable
malla de alambre, autoclavable
gaze de fil de métal, stérilisable
Maglia metallica, sterilizzabile

Spickdrähte

Wire Drills
Brocas filiformes
Broches filiformes
Perforatori filiformi

Knochenchirurgie

Bone Surgery
Cirugía ósea
Chirurgie osseuse
Chirurgia ossea

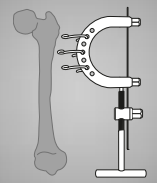

1

Kirschner



Trokarspitze
Trocar pointed
Punta trocar
Pointe de trocart
Punta a tre quarti

St 10

	Länge Length Largo Longueur Lunghezza					
Ø	60 mm / 2 1/8"	120 mm / 5"	140 mm / 5 1/2"	160 mm / 6 1/4"	310 mm / 12 1/8"	
1,6 mm	22-622-16-05	22-626-16-05	22-628-16-05	22-630-16-05	22-632-16-05	

Kirschner



Trokarspitze mit rundem Schaft
Trocar, pointed, with round end
Punta trocar con cabo redondo
Pointe de trocart avec tige ronde
Punta a tre quarti

St 10

	Länge Length Largo Longueur Lunghezza					
Ø	60 mm / 2 1/8"	100 mm / 3 7/8"	120 mm / 5"	140 mm / 5 1/2"	160 mm / 6 1/4"	310 mm / 12 1/8"
1,6 mm	22-623-16-05	22-625-16-05	22-627-16-05	22-629-16-05	22-631-16-05	22-633-16-05

22
23

Spongiosaentnahmefräse

Cancellous Bonegraft Mill
Extractor para esponjosa
xtracteur pour spongiosa
Fresa per spongiosa



23-190-05-07

22.5 cm / 8 3/4"

Beckenkammfräse, komplett
Iliac crest mill, complete
Fresadora de la cresta iliaca, completo
Fraise de la creste iliaque, complete
Fresa per cresta iliaca, completo



23-190-06-07

22.5 cm / 8 3/4"

Beckenkammfräse, komplett
Iliac crest mill, complete
Fresadora de la cresta iliaca, completo
Fraise de la creste iliaque, complete
Fresa per cresta iliaca, completo



23-192-00-71

CarpalStick
nur zum Einmalgebrauch
single-use only
de un solo uso
à usage unique
monouso

STERILE

Hämmer

Mallets
Martillos
Maillets
Martelli

Knochenchirurgie

Bone Surgery
Cirugía ósea
Chirurgie osseuse
Chirurgia ossea

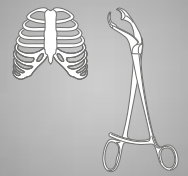

Kopf	Kopfgewicht
Head	Head weight
Cabeza	Peso de la cabeza
T te	Poids de t te
Testa	Peso della testa

34 mm **410 g**

Kopf	Kopfgewicht
Head	Head weight
Cabeza	Peso de la cabeza
T te	Poids de t te
Testa	Peso della testa

30 mm **200 g**



1 2

Cottle
23-215-19-07

19 cm 7⁴/₈

plan konvex
plane convex
plano convexo
plan convexe
plano convesso

Gesamtgewicht
Total weight
Peso total
Poids total
Peso totale

300 g



1 2

23-218-22-04

25 cm 9⁷/₈



Gesamtgewicht
Total weight
Peso total
Poids total
Peso totale

650 g

22
23

Hämmer

Mallets
Martillos
Maillets
Martelli

Kopf	Kopfgewicht
Head	Head weight
Cabeza	Peso de la cabeza
Tête	Poids de tête
Testa	Peso della testa
34 mm	460 g

Kopf	Kopfgewicht
Head	Head weight
Cabeza	Peso de la cabeza
Tête	Poids de tête
Testa	Peso della testa
34 mm	470 g



23-256-00-04

Spare facing
Tapa de repuesto
Placque de rechange
Placche di ricambio



23-240-29-04,
23-253-22-04,
23-254-22-04



1 2

23-240-29-04

25 cm 9⁷/₈

plane Kunststoff , konvex Stahl ,
plane nylon , convex steel ,
plano nilón , convexo acero ,
plan nylon , convexe acier ,
plano nilon , convesso acciaio ,



Gesamtgewicht
Total weight
Peso total
Poids total
Peso totale

700 g



1 2

23-244-24-04

25 cm 9⁷/₈



Gesamtgewicht
Total weight
Peso total
Poids total
Peso totale

710 g

Hämmer

Mallets
Martillos
Maillets
Martelli

Knochenchirurgie

Bone Surgery
Cirugía ósea
Chirurgie osseuse
Chirurgia ossea

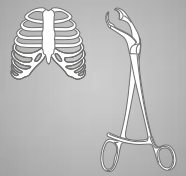

Kopf
Head
Cabeza
T te
Testa
34 mm

Kopfgewicht
Head weight
Peso de la cabeza
Poids de t te
Peso della testa
400 g

Kopf
Head
Cabeza
T te
Testa
34 mm

Kopfgewicht
Head weight
Peso de la cabeza
Poids de t te
Peso della testa
270 g



23-256-00-04

rsatzbacke
Spare facing
Tapa de repuesto
Placque de rechange
Placche di ricambio



23-240-29-04,
23-253-22-04,
23-254-22-04

1 2



23-256-00-04

rsatzbacke
Spare facing
Tapa de repuesto
Placque de rechange
Placche di ricambio



23-240-29-04,
23-253-22-04,
23-254-22-04

1 2

23-253-22-04

25 cm 9 7 8

plan Kunststoff , konvex Stahl ,
plane nylon , convex steel ,
plano nilón , convexo acero ,
plan nylon , convexe acier ,
plano nilon , convesso acciaio ,



Gesamtgewicht
Total weight
Peso total
Poids total
Peso totale

640 g

23-254-22-04

25 cm 9 7 8



Gesamtgewicht
Total weight
Peso total
Poids total
Peso totale

510 g

Hämmer

Mallets
Martillos
Maillets
Martelli

Kopf Kopfgewicht
Head Head weight
Cabeza Peso de la cabeza
Tête Poids de tête
Testa Peso della testa
34 mm 530 g



1 2

23-260-01-04

25 cm 9 7/8"



Gesamtgewicht
Total weight
Peso total
Poids total
Peso totale

770 g

Kopf Kopfgewicht
Head Head weight
Cabeza Peso de la cabeza
Tête Poids de tête
Testa Peso della testa
25 mm 130 g



1 2

23-262-19-04

19 cm / 7 4/8"



Gesamtgewicht
Total weight
Peso total
Poids total
Peso totale

260 g

23-262-90-98

ersatzbacken Paar
Spare facings pair
Tapas de repuesto par
Plaques de rechange paire
Placche di ricambio paio



23-262-19-04,
23-264-19-04

Kopf Kopfgewicht
Head Head weight
Cabeza Peso de la cabeza
Tête Poids de tête
Testa Peso della testa
25 mm 140 g



1 2

Herbert
23-264-19-04

19 cm / 7 4/8"

für Ulnakopfprothesen
for ulna head prosthesis
para prótesis de la cabeza ulnar
pour prothèse de la tête ulna
protesi per la testa ulnare



Gesamtgewicht
Total weight
Peso total
Poids total
Peso totale

270 g

Raspatorien

Periosteal levators
Periostótomos
Rugines-raspatoires
Periostotomi

Knochenchirurgie

Bone Surgery
Cirugía ósea
Chirurgie osseuse
Chirurgia ossea

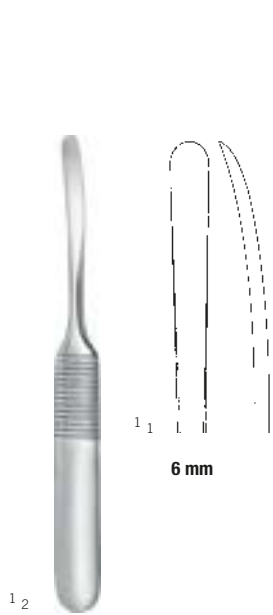
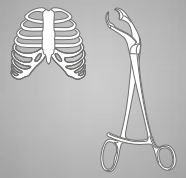

Williger
23-434-13-07
12,5 cm / 4 7/8"
massiv
solid
macizo
solide
pieno

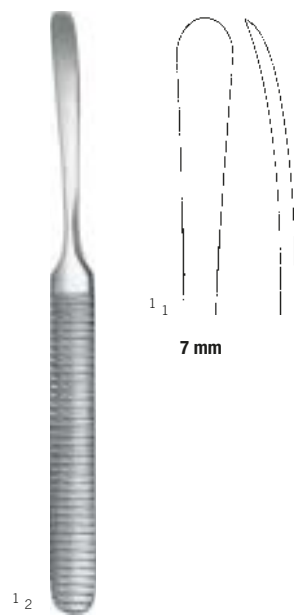

Williger
23-436-07-07
16 cm / 6 1/8"
massiv
solid
macizo
solide
pieno

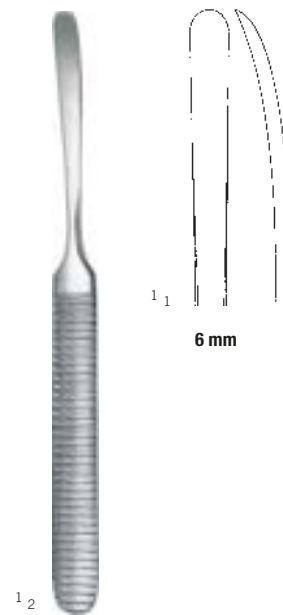

Williger
23-436-16-07
16 cm / 6 1/8"
massiv
solid
macizo
solide
pieno

Raspatorien, Repositionszangen

Periosteal levators, Reposition Forceps

Periostótomos, Pinzas para reposición

Rugines-raspatoires, Pincas réduction

Periostotomi, Pinze per riposizioni



1_1

23-441-17-07

17 cm / 6 5/8"

rechts gebogen
right curved
curvo a la derecha
courbé droite
curvo destro

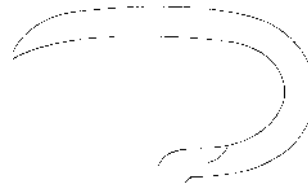

23-443-17-07

17 cm / 6 5/8"

links gebogen
left curved
curvo a la izquierda
courbé gauche
curvo sinistro

für Erwachsene
for adults
para adultos
pour adultes
per adulti

Doyen
23-441-17-07 -
23-443-17-07

Rippenraspatorien, mit Hohlheft
Rib Raspatories, with hollow handle
Legras costales, con mango hueco
Rugines pour le périoste costale, avec manche creux
Periostotomi costali, con manico vuoto

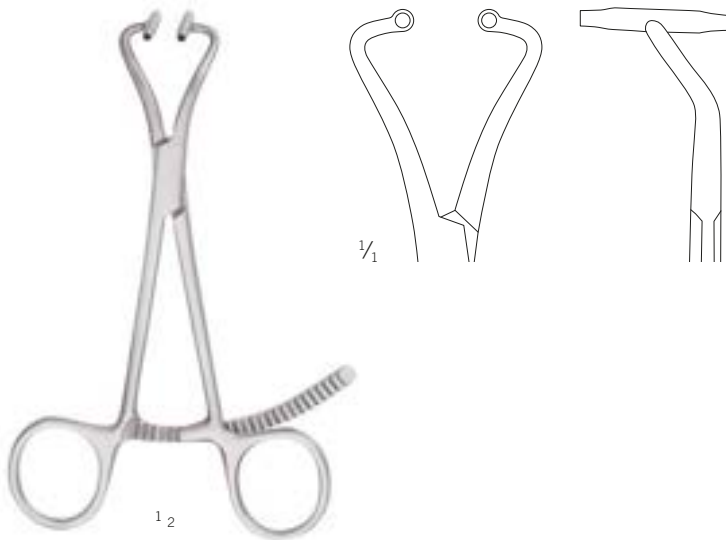

1_1

23-721-15-07

13 cm / 5 1/8"

Fixierhand

Fixation hand
Molde de mano para fijación
Main de fixation
Mano di fissaggio

Knochenchirurgie

Bone Surgery
Cirugía ósea
Chirurgie osseuse
Chirurgia ossea

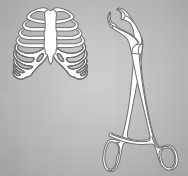

1/4

23-960-01-04

Fixierhand für Kinder
Fixation hand for children
Molde de mano para fijación para niños
Main de fixation pour enfants
Mano di fissaggio per bambini

Pb



1/4

23-960-02-04

Fixierhand für Erwachsene
Fixation hand for adults
Molde de mano para fijación para adultos
Main de fixation pour adultes
Mano di fissaggio per adulti

Pb



23-960-24-04

Silikonring, klein
Silicone ring, small
Arandela de silicona, pequeño
Anneau en silicone, petit
Anello in silicone, piccolo

24 x 3 mm



23-960-27-04

Silikonring, mittel
Silicone ring, medium
Arandela de silicona, mediana
Anneau en silicone, moyen
Anello in silicone, medio

27 x 3 mm

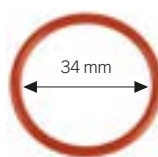

23-960-44-04

Silikonring, groß
Silicone ring, large
Arandela de silicona, grande
Anneau en silicone, grand
Anello in silicone, grande

34 x 3 mm

22
23

Handhalter

Hand Restrainer

Sujetador de mano

Reteneur pour main

Fissatore per mano



1 2

23-962-00-07

zur schnellen und sicheren Fixierung der Hand

To hold the hand quickly and efficiently in any desired position

Para mantener la mano en cualquier posición deseada, eficiente y rápidamente

Pour immobiliser de façon rapide et sûre la main dans n'importe quelle position

Per una rapida e sicura fissazione alla mano in qualsiasi posizione desiderata

Radiusbank

Wrist Positioning Device
Dispositivo de posicionamiento de la muñeca
Dispositif de fixation du poignet
Supporto per radio

Knochenchirurgie

Bone Surgery
Cirugía ósea
Chirurgie osseuse
Chirurgia ossea

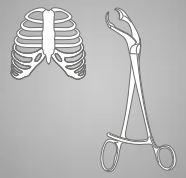

1 2

23-963-00-04

Radiusbank, komplett
Wrist Positioning Device, complete
Dispositivo de posicionamiento de la muñeca, completo
Dispositif de fixation du poignet, complet
Supporto per radio, completo

23-963-01-04

Unterteil
Lower part
Parte inferior
Partie inférieure
Parte inferiore

23-963-02-04

Oberteil
Upper part
Parte superior
Partie supérieure
Parte superiore

22
23

Spezialinstrumente
Special instruments
Instrumentos especiales
Instruments spécifiques
Strumenti speciali

28

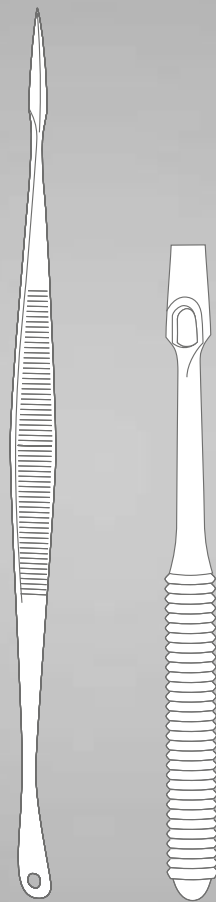

Brustdissektor

Breast Dissector

Disector de mama

Dissecteur mammaire

Dissettore mammario



1/2

28-100-02-07

34 cm / 13 3/8"

Brustdissektor, bajonett
Breast Dissector, bayoneta
Disector de mama, bayoneta
Dissecteur mammaire, baïonnette
Dissettore mammario, baïonnette

AI



1/2

28-100-03-07

37 cm / 14 4/8"

Brustdissektor, bajonett
Breast Dissector, bayoneta
Disector de mama, bayoneta
Dissecteur mammaire, baïonnette
Dissettore mammario, baïonnette

AI



1/2

28-100-04-07

36 cm / 14 1/8"

Brusthakendissektor
Hook Dissector
Gancho disector mama
Dissecteur à croc. mammaire
Dissettore mammario a uncino

AI

Brustretractor

Breast Retractor
Retractor mama
Dissecteur mammaire
Dissettoe mammario

Spezialinstrumente

Special instruments
Instrumentos especiale
Instruments spécifiques
Strumenti speciali

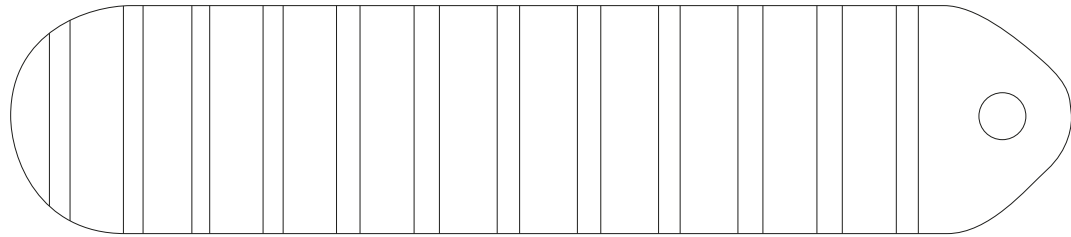
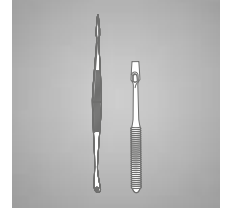

140 x 30 mm
28-100-06-07

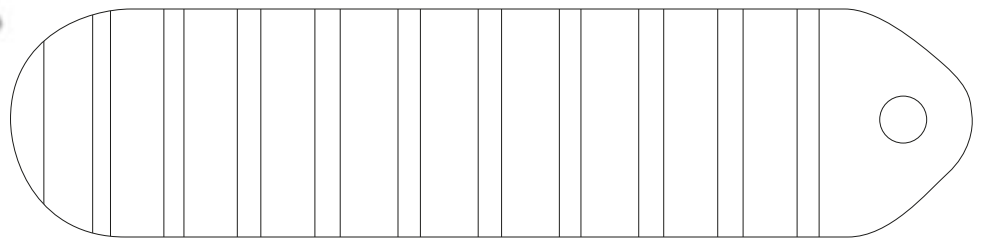
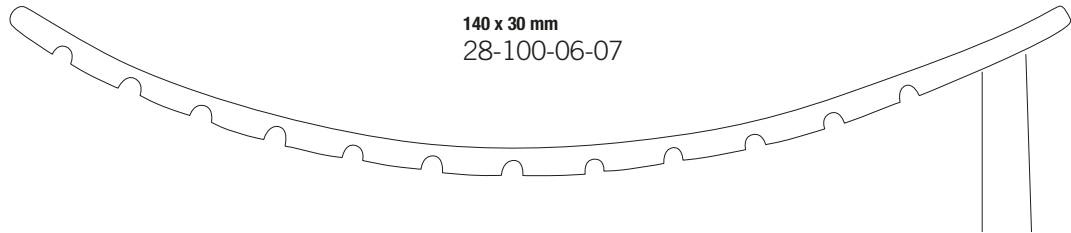

125 x 30 mm
28-100-05-07

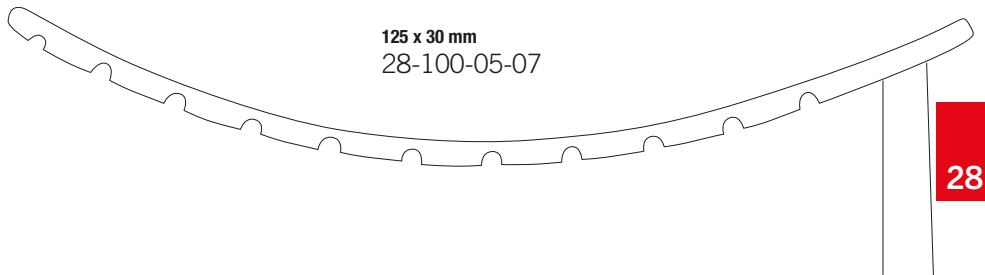

28

1/2

28-100-05-07 -
28-100-06-07

27 cm / 10 5/8"

Brustretractor
Breast Retractor
Retractor mama
Dissecteur mammaire
Dissettoe mammario

AI

Brust

Breast
Mama
Mammaire
Mammario



28-100-07-07

28 cm /11"

Brustheber für Mammaplastik
Breast Elevator for Mammaplasty
Elevador de mama para mamoplastia
Élévateur mammaire pour plastie mammaire
Elevatore mammario per mammoplastica



28-100-10-07 -
28-100-13-07

Mamillenring, stumpf
Areola marker, blunt
Anillo marc. pezón, romo
Marqueur pour aréole, mousse
Marcatore p. areola, smusso

28-100-10-07	Ø 36 mm
28-100-11-07	Ø 40 mm
28-100-12-07	Ø 42 mm
28-100-13-07	Ø 45 mm

Milienmesser, Lupusinstrumente

Millium Knife, Lupus Instruments

Chuchillo para milium, Instrumentos para lupus

Couteau pour milium, Instruments pour les lupus

Bisturi per milie, Strumenti per lupus

Spezialinstrumente

Special instruments

Instrumentos especiale

Instrumenti specifici

Strumenti speciali

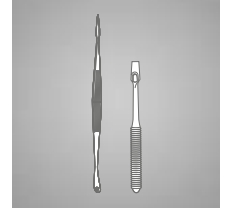

Lupusschaber
Lupus Scraper
Rascador para lupus
Rugine pour les lupus
Raschiatoio per lupus

1/2

3,7 mm
Vidal
28-135-14-07
13 cm / 5 1/8"

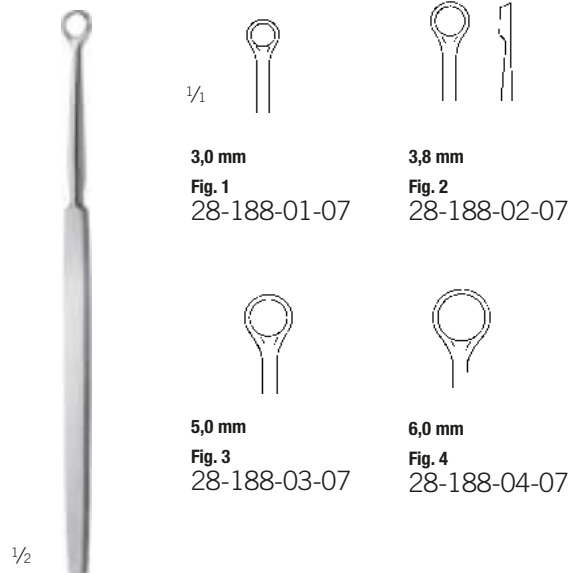

1/4

3,0 mm
Fig. 1
28-188-01-07

3,8 mm
Fig. 2
28-188-02-07

5,0 mm
Fig. 3
28-188-03-07

6,0 mm
Fig. 4
28-188-04-07

1/2

Fox
28-188-01-07 -
28-188-04-07
14 cm / 5 4/8"

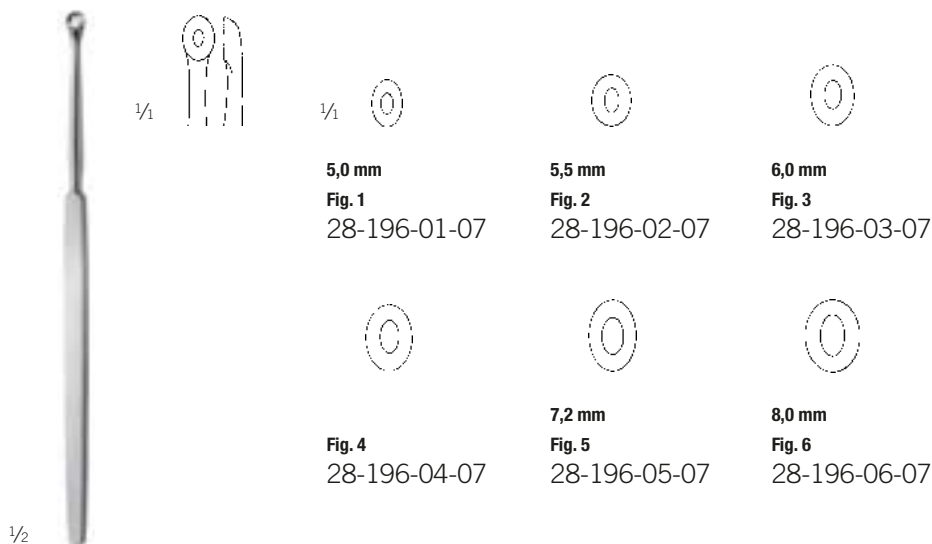

1/4

5,0 mm
Fig. 1
28-196-01-07

5,5 mm
Fig. 2
28-196-02-07

6,0 mm
Fig. 3
28-196-03-07

Fig. 4
28-196-04-07

7,2 mm
Fig. 5
28-196-05-07

8,0 mm
Fig. 6
28-196-06-07

1/2

Wolff
28-196-01-07 -
28-196-06-07
14 cm / 5 4/8"

Hauthäkchen, Hauttrephinen

Skin Hooklets, Dermal Punches
 Ganchitos para piel, Trépanos para piel
 rignes cutanées, Trépans cutanés
 Uncini cutanei, Trefine cutanee



Kilner
 28-203-15-07
 14,5 cm / 5 7/8"
 scharf
 sharp
 agudo
 pointu
 acuto



Gillies
 28-207-18-07 -
 28-209-18-07
 18 cm / 7 1/8"

1/1 ?
Fig. 1
 28-207-18-07
 kleiner Radius, scharf
 small radius, sharp
 radio pequeño, agudo
 petit rayon, affuté
 raggio piccolo, acuto

?
Fig. 2
 28-209-18-07
 großer Radius, scharf
 large radius, sharp
 radio grande, agudo
 grand rayon, affuté
 raggio grande, acuto



Kaye
 28-215-03-07 -
 28-215-04-07
 13 cm / 5 1/8"

1/1 ?
 28-215-03-07

1/1 ?
 28-215-04-07



Keyes
 28-240-02-07 -
 28-240-08-07
 11 cm / 4 3/8"

1/1 ○
Ø 2,0 mm 28-240-02-07
Ø 3,0 mm 28-240-03-07
Ø 4,0 mm 28-240-04-07

1/1 ○
Ø 5,0 mm 28-240-05-07
Ø 6,0 mm 28-240-06-07
Ø 7,0 mm 28-240-07-07
Ø 8,0 mm 28-240-08-07

Komedoneninstrumente

Comedone extractors
 extractores para comedones
 Tire-comédons
 Tiracomedoni

Spezialinstrumente

Special instruments
 Instrumentos especiales
 Instruments spécifiques
 Strumenti speciali

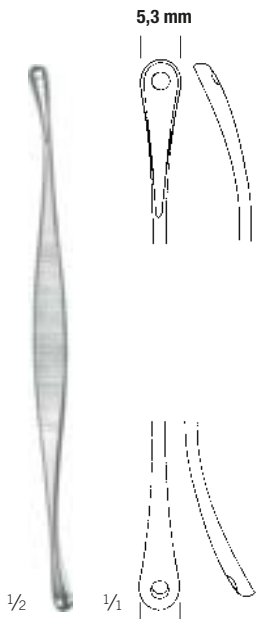
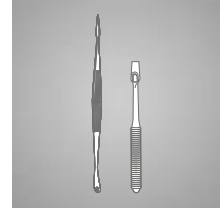

Unna
 28-261-14-07
 14,5 cm / 5 7/8"



Unna
 28-263-14-07
 14 cm / 5 4/8"

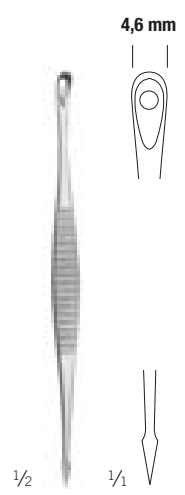

Saalfeld
 28-271-10-07
 11 cm / 4 3/8"



Saalfeld
 28-275-14-07
 14,5 cm / 5 7/8"

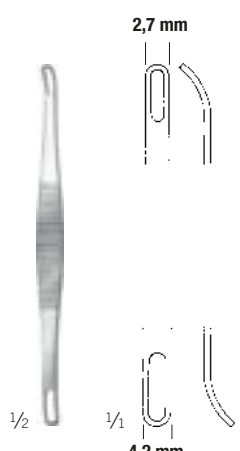

Schamberg
 28-279-10-07
 9,5 cm / 3 7/8"

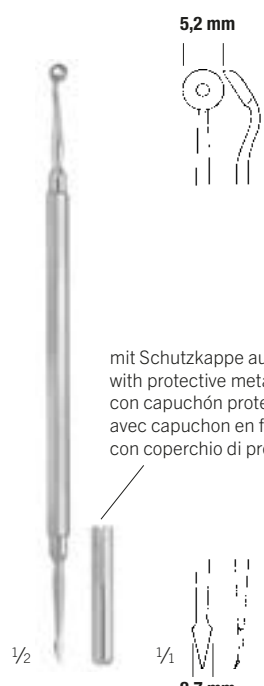

Katsch
 28-294-14-07
 16 cm / 6 2/8"

mit Schutzkappe aus Metall
 with protective metal cap
 con capuchón protector metálico
 avec capuchon en fer
 con coperchio di protezione in metallo



Unna-Vidal
 28-296-11-07
 11 cm / 4 3/8"

Komedoneninstrumente, Face-lift-Scheren

Comedone extractors, Face-lift Scissors

extractores para comedones, Tijeras para Face-lift

Tire-comédons, Ciseaux pour Face-lift

Tiracomedoni, Forbici per Face-lift

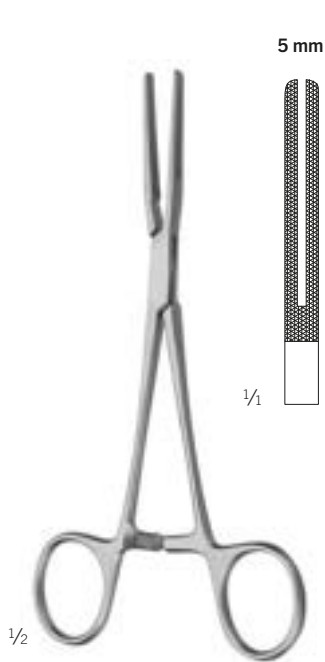

Aiach
28-298-16-07

16 cm / 6 2/8"

Klemme
Forceps
Pinza mosquito
Pince
Pinza

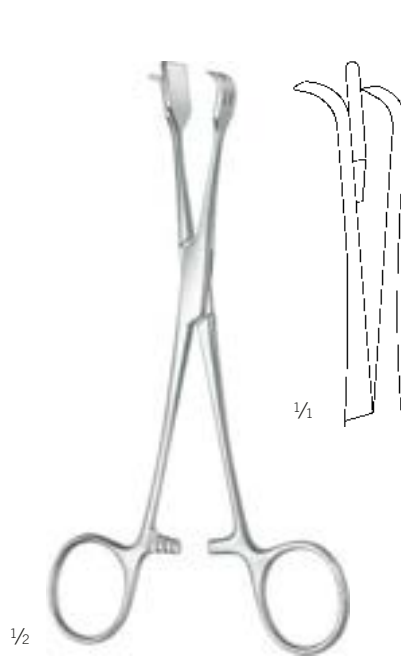

d'Assumpção
28-300-15-07

16 cm / 6 2/8"



Pitanguy
28-372-16-07

16 cm / 6 2/8"

Markierer
Facelift marker
Marcador
Marqueur
Marcatore

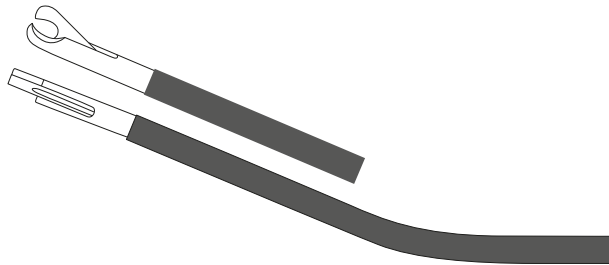

28-370-12-07

links gebogen
left curved
curvo a la izquierda
courbé à gauche
curvo sinistro

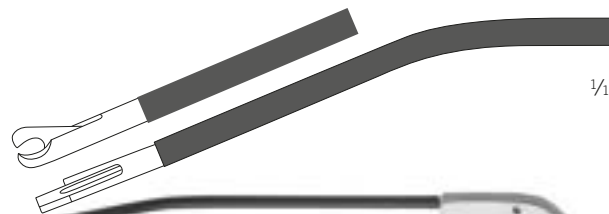

28-371-12-07

rechts gebogen
right curved
curvo a la derecha
courbé à droite
curvo destro

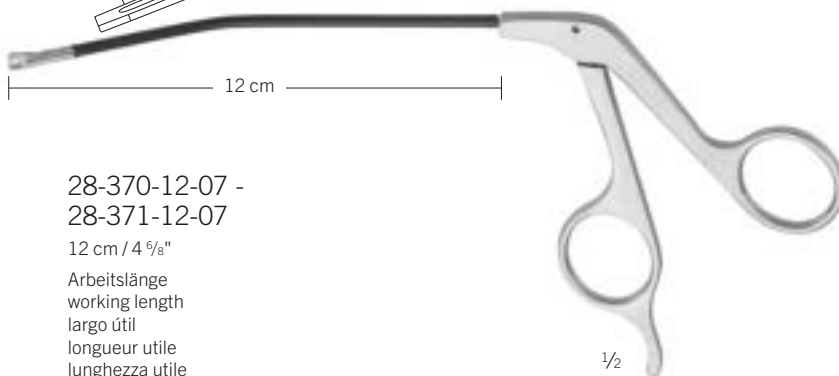

28-370-12-07 -
28-371-12-07

12 cm / 4 5/8"

Arbeitslänge
working length
largo útil
longueur utile
lunghezza utile

Zirkel
Calipers
Compasses
Compass
Compassi

35

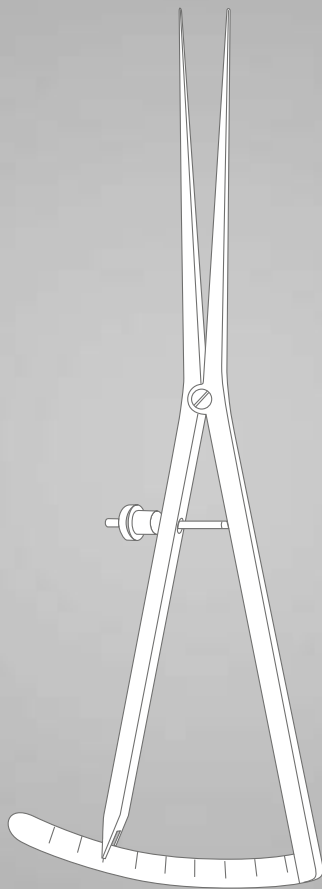

Zirkel

Calipers
Compasses
Compas
Compassi



1/2

Castroviejo
35-133-07-07

8 cm / 3 1/8"

Bereich
effective range
alcance eficaz
série effectif
rango effective

0-20 mm



1/2

Castroviejo
35-133-09-07

8 cm / 3 1/8"

Bereich
effective range
alcance eficaz
série effectif
rango effective

0-20 mm



1/2

Castroviejo- pker
35-134-09-07

9 cm / 3 4/8"

Bereich
effective range
alcance eficaz
série effectif
rango effective

0-40 mm

Otologie
Otology
Otología
Otologie
Otologia

36

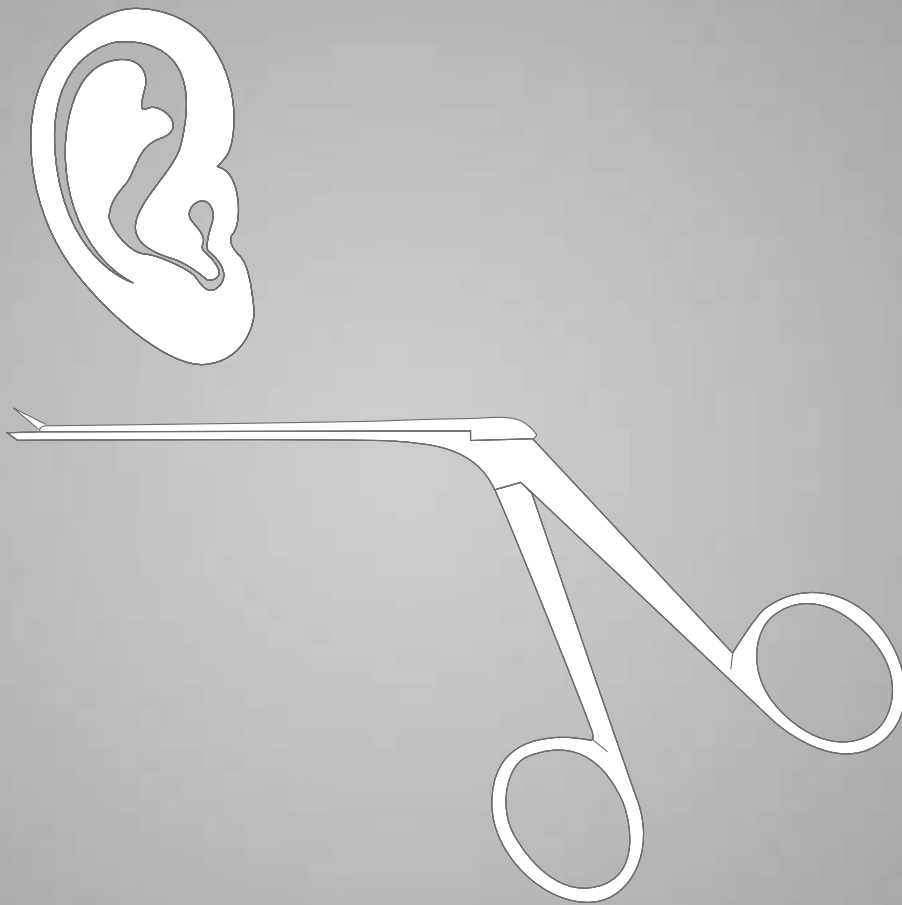

Ohrpinzetten, Nasenspekula

Nasal Specula, Ear Forceps

spéculos nasales, Pinzas auriculares

Spéculums nasaux, Pincas auriculaires

Specoli nasali, Pinze auricolari



ansen
36-395-16-07
16 cm / 6 2/8"



Hartmann-Halle
36-845-01-07 -
36-845-03-07
16 cm / 6 2/8"

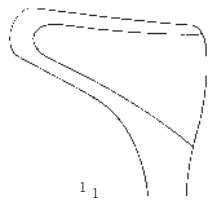

Fig. 1
36-845-01-07
Blätter
blades
hojas
lames
lame
27 mm

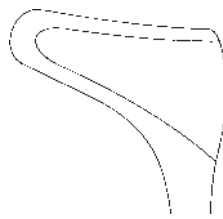

Fig. 2
36-845-02-07
Blätter
blades
hojas
lames
lame
31 mm

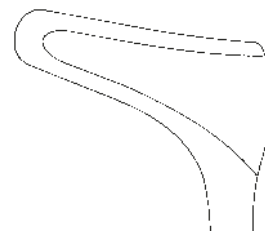

Fig. 3
36-845-03-07
Blätter
blades
hojas
lames
lame
35 mm

Nasenspekula

Nasal Specula
spéculos nasales
Spéculums nasaux
Specoli nasali

Otologie

Otology
Otología
Otologie
Otologia

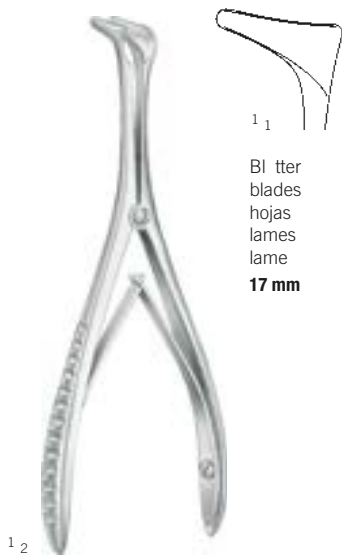
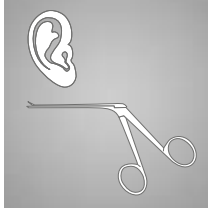

Bl tter
blades
hojas
lames
lame
17 mm

Martin
36-848-13-07
13 cm / 5 1/8"



Bl tter
blades
hojas
lames
lame
16 mm

Tieck-Halle
36-852-13-07
13 cm / 5 1/8"



Killian
36-856-01-07 -
36-856-04-07

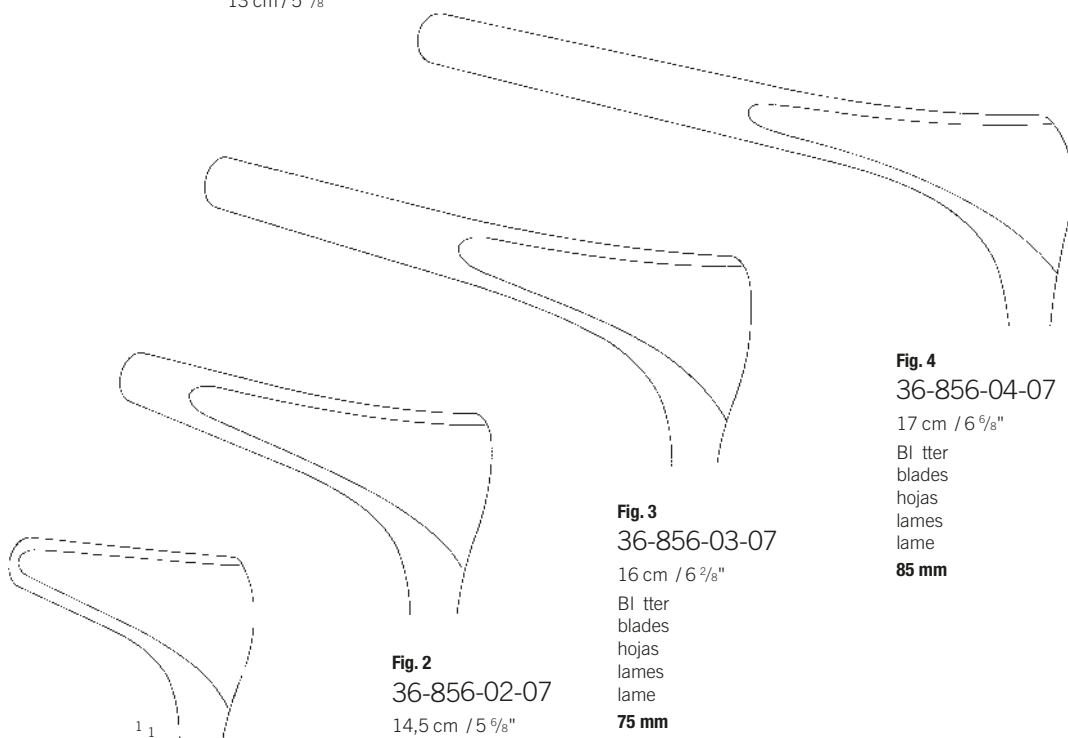

Fig. 1
36-856-01-07
14 cm / 5 4/8"
Bl tter
blades
hojas
lames
lame
35 mm

Fig. 2
36-856-02-07
14,5 cm / 5 6/8"
Bl tter
blades
hojas
lames
lame
50 mm

Fig. 3
36-856-03-07
16 cm / 6 2/8"
Bl tter
blades
hojas
lames
lame
75 mm

Fig. 4
36-856-04-07
17 cm / 6 6/8"
Bl tter
blades
hojas
lames
lame
85 mm

Nasenspekula

Nasal Specula
spéculos nasales
Spéculums nasaux
Specoli nasali



1 2

Mod. Wien
36-858-14-07
13,5 cm / 5 3/8"

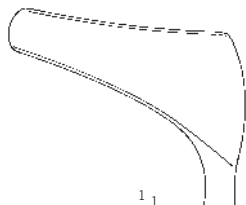

1 1

Bl tter
blades
hojas
lames
lame
30 mm



1 2

Cottle
36-859-35-07 -
36-859-90-07

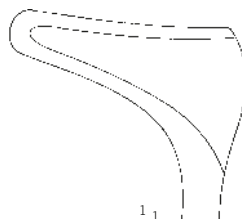

1 1

Fig. 1
36-859-35-07
13,5 cm / 5 3/8"
Bl tter
blades
hojas
lames
lame
35 mm

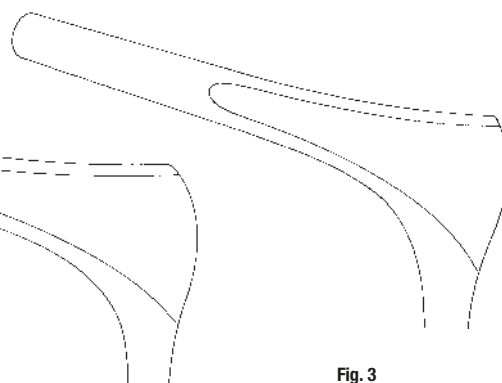

Fig. 2
36-859-50-07
14 cm / 5 4/8"
Bl tter
blades
hojas
lames
lame
50 mm

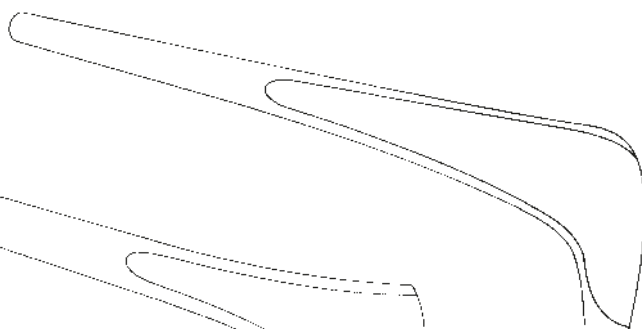
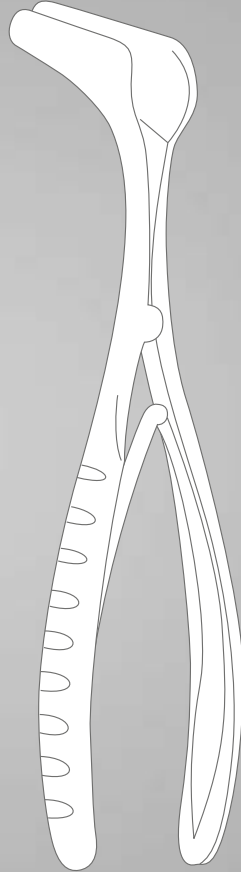
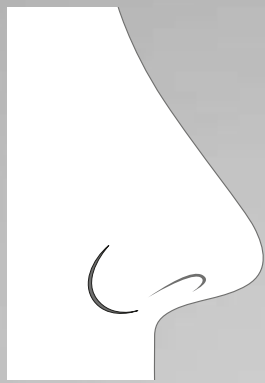

Fig. 3
36-859-75-07
16 cm / 6 2/8"
Bl tter
blades
hojas
lames
lame
75 mm

Fig. 4
36-859-90-07
16 cm / 6 2/8"
Bl tter
blades
hojas
lames
lame
85 mm

Rhinologie
Rhinology
Rinología
Rhinologie
Rinologia

37



Nasentamponpinzetten, Nasentamponzangen

Nasal Tampon Forceps, Nasal Tampon Forceps
 Pinzas para taponamiento, Pinzas para taponamiento
 Pincers pansements, Pincers pansements
 Pinze per medicature, Pinze per medicature

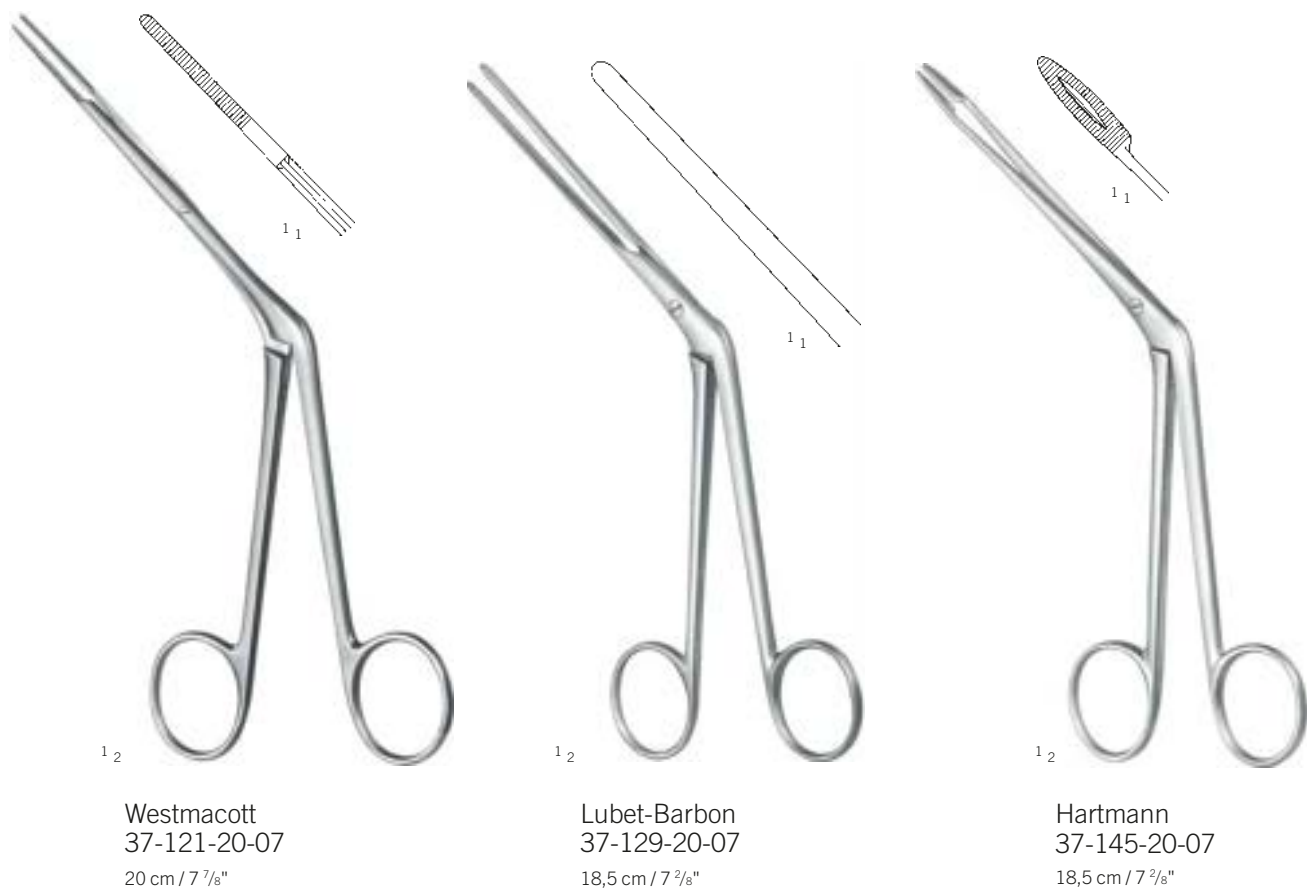
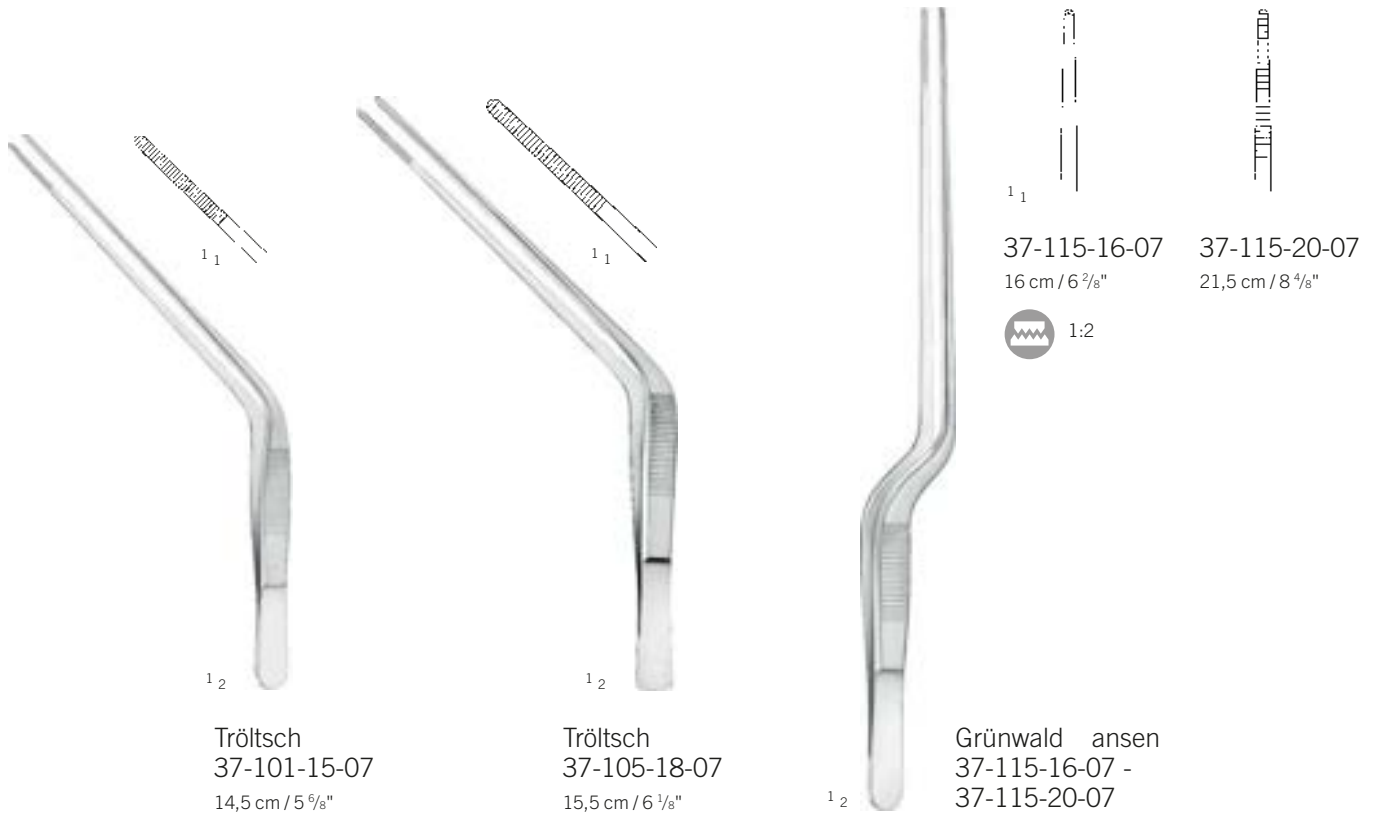

Nasenpolypenzange
 Nasal Polypus Forceps
 Pinza para pólipos nasales
 Pince à polypes nasaux
 Pinza per polipi nasali

Septumzangen

Septum Forceps
 Pinzas para tabique nasal
 Pincas pour la cloison nasale
 Pinze per il setto nasale

Rhinologie

Rhinology
 Rinología
 Rhinologie
 Rinologia

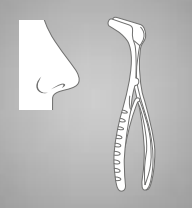

5,0 mm
 Knight
 37-207-18-07
 17 cm / 6 7/8"

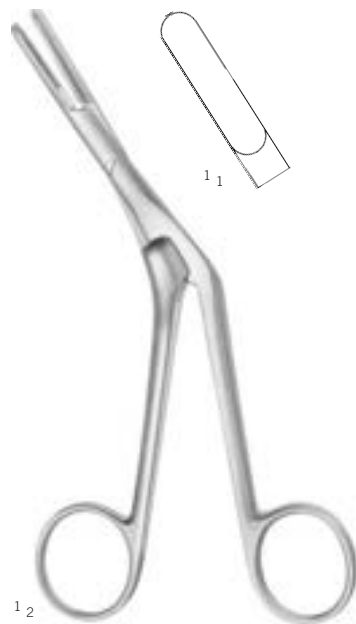

5,5 mm
 Graig
 37-213-18-07
 16 cm / 6 1/8"



8,5 mm
 37-215-01-07
 links gebogen
 left curved
 curvo por izquierdo
 courbé gauche
 curvo a sinistra

37-215-01-07
 15,5 cm / 6 1/8"



Brünings
 37-227-01-07 -
 37-227-04-07
 16,5 cm / 6 4/8"



6,6 mm
 Fig. 1
 37-227-01-07



7,6 mm
 Fig. 2
 37-227-02-07



8,7 mm
 Fig. 3
 37-227-03-07



9,6 mm
 Fig. 4
 37-227-04-07

37

Scharfe Nasenzangen, Siebbeinzangen

Nasal Cutting Forceps, Ethmoid Bone Forceps





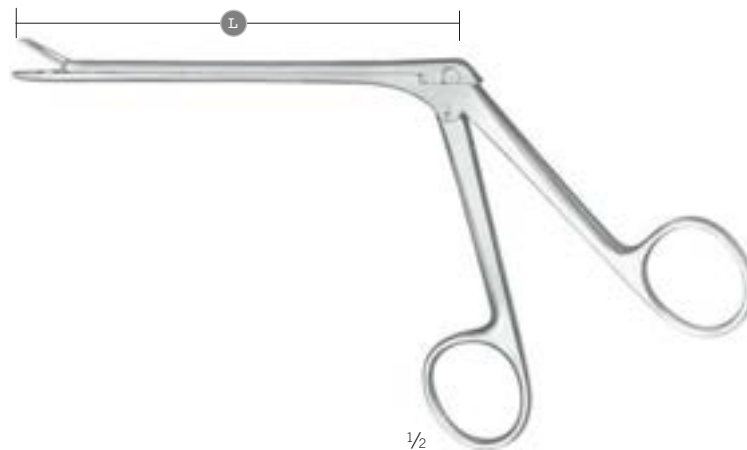

Pinzas nasales cortantes, Pinzas para etmoides

Pinces nasales coupantes, Pinces étmoidales

Pinze taglianti per il naso, Pinze etmoidali

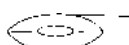
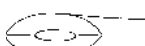

Weil-Blakesley
37-255-01-07 -
37-258-04-07

Maulbreite Jaw width Anchura de la boca Largeur de mors Larghezza della bocca		gerade straight recto droit diritto	45° aufgewinkelt angled upward acodado arrib angulé vers le haut angolato verso l'alto	90° aufgewinkelt angled upward acodado arrib angulé vers le haut angolato verso l'alto
				
		$\frac{1}{1}$	$\frac{1}{1}$	
		L	12 cm	12 cm
Fig. 1 3,0 mm		37-255-01-07	37-256-01-07	37-258-01-07
Fig. 2 3,5 mm		37-255-02-07	37-256-02-07	37-258-02-07
Fig. 3 4,5 mm		37-255-03-07	37-256-03-07	37-258-03-07
Fig. 4 5,5 mm		37-255-04-07	37-256-04-07	37-258-04-07
Fig. 5 6,0 mm		37-255-05-07		

Scharfe Nasenzangen





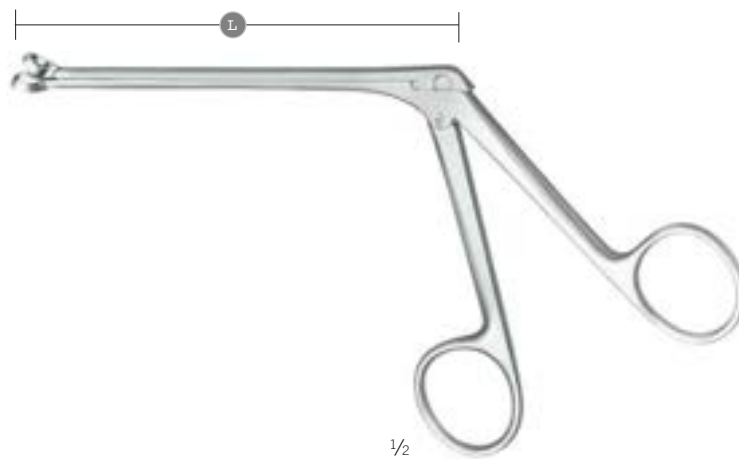
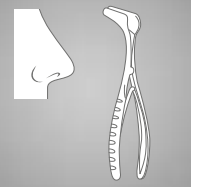

Nasal Cutting Forceps
 Pinzas nasales cortantes
 Pincas nasales coupantes
 Pinze taglianti per il naso

Rhinologie

Rhinology
 Rinologia
 Rhinologie
 Rinologia



Hartmann Schmieden
 37-309-01-07 - 37-313-12-07
 37-309-04-07

Maulbreite Jaw width Anchura de la boca Largeur de mors Larghezza della bocca	1/1		
		Hartmann	Schmieden
	L	12 cm	12 cm
Fig. 1 Ø 5,0 mm		37-309-01-07	
Fig. 2 Ø 7,0 mm		37-309-02-07	
Fig. 3 Ø 9,0 mm		37-309-03-07	
Fig. 4 Ø 11,0 mm		37-309-04-07	
8,0 mm			37-313-12-07

Septumquetschzangen

Septum Morselizers

Pinzas para aplastamiento

Pinces-gouge pour la cloison nasale

Pinze contundente per il setto nasale



eine Schneide gezahnt
one toothed cutting edge
una hoja dentada
une lame dentelée
una lama dentata

Caplan
37-331-20-07
20 cm / 7 7/8"

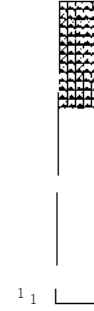

Rubin
37-335-20-07
20 cm / 7 7/8"

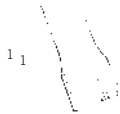

Rubin
37-335-01-07
Schutzkappe
Protection Cap
Caperuza protectora
Capuchon protecteur
Calotta protettiva



37-335-21-07

Rubin
37-335-21-07
18,5 cm / 7 3/8"

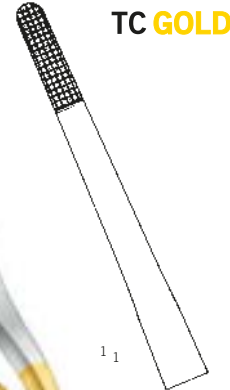

TC GOLD

Rubin
37-337-21-07
18,5 cm / 7 3/8"

Rhinoplastik-Messer

Rhinoplastic Knives

Cuchillos rinoplásticos

Couteaux pour plastie du nez

Bisturi per plastica nasale

Rhinologie

Rhinology

Rinologia

Rhinologie

Rinologia

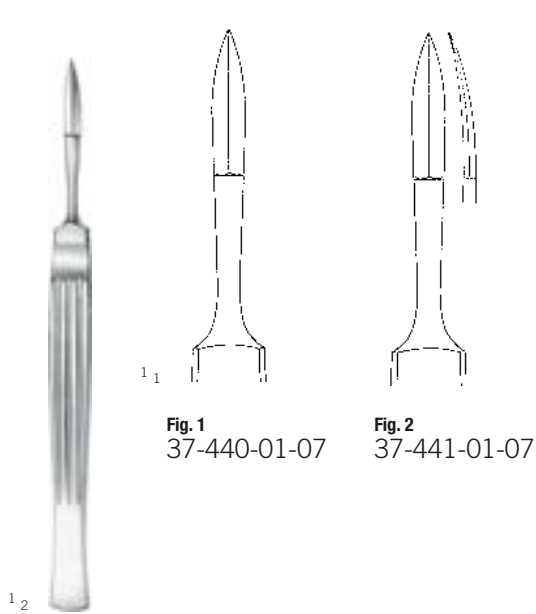
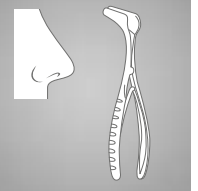
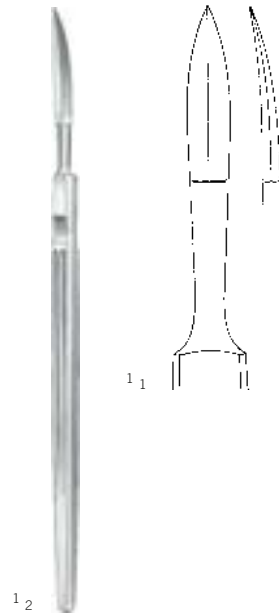

Fig. 1
37-440-01-07

Fig. 2
37-441-01-07

oseph
37-440-01-07 -
37-441-01-07
15 cm / 5 7/8"



Fomon
37-444-16-07
16,5 cm / 6 4/8"

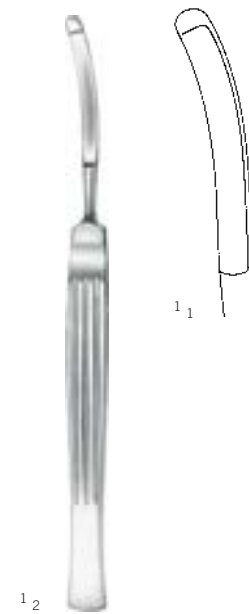

Converse
37-459-16-07
16 cm / 6 2/8"

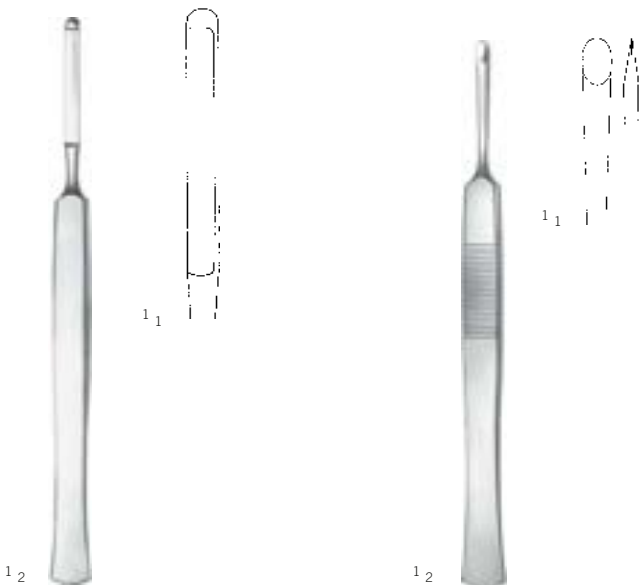

oseph
37-466-15-07
15,5 cm / 6 1/8"

Cottle
37-468-15-07
14 cm / 5 4/8"

Septummesser, Schwingmesser

Septum Knives, Swivel Knives

Cuchillos para tabique nasal

Bistouris pour la cloison nasale

Bisturi per il setto nasale



Freer
37-484-15-07

15 cm / 5 7/8"

Mukosamesser
Mucosa Knife
Cuchillo para mucosa
Couteau pour muqueuse
Bisturi per mucosa



Freer
37-497-19-07

19 cm / 7 4/8"



Freer
37-499-19-07

18,5 cm / 7 3/8"

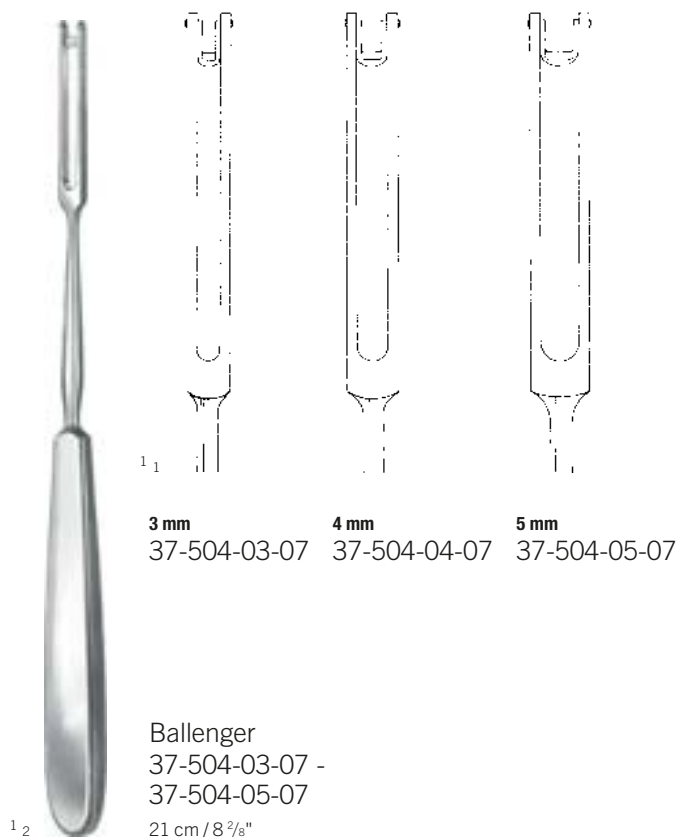

3 mm 37-504-03-07
4 mm 37-504-04-07
5 mm 37-504-05-07

Ballenger
37-504-03-07 -
37-504-05-07
21 cm / 8 2/8"

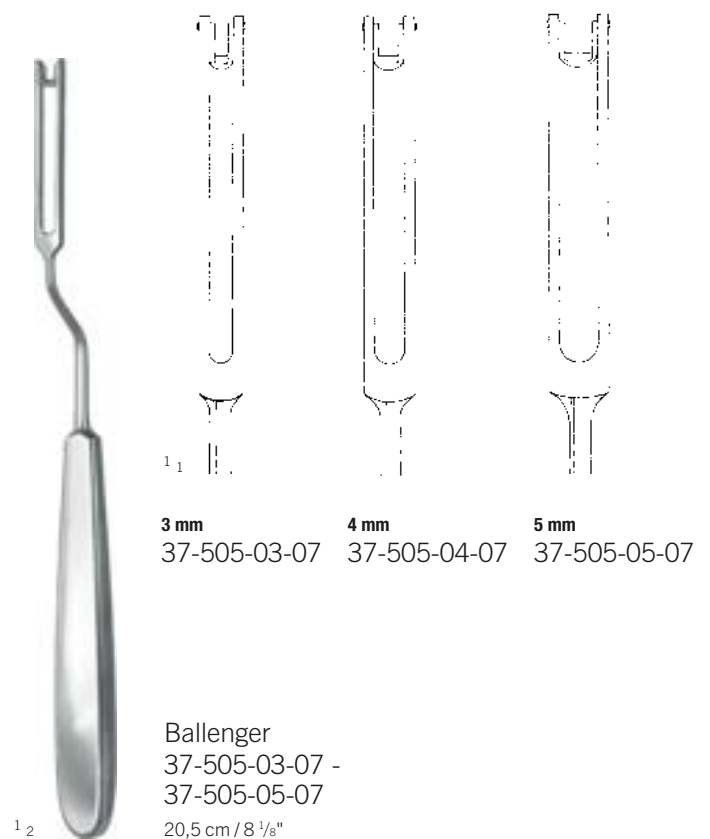

3 mm 37-505-03-07
4 mm 37-505-04-07
5 mm 37-505-05-07

Ballenger
37-505-03-07 -
37-505-05-07
20,5 cm / 8 1/8"

Septumelevatorien

Septum levators

levadores para tabique nasal
lévateurs pour la cloison nasale
levatori per il setto nasale

Rhinologie

Rhinology
Rinologia
Rhinologie
Rinologia

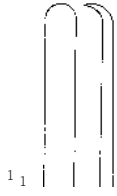
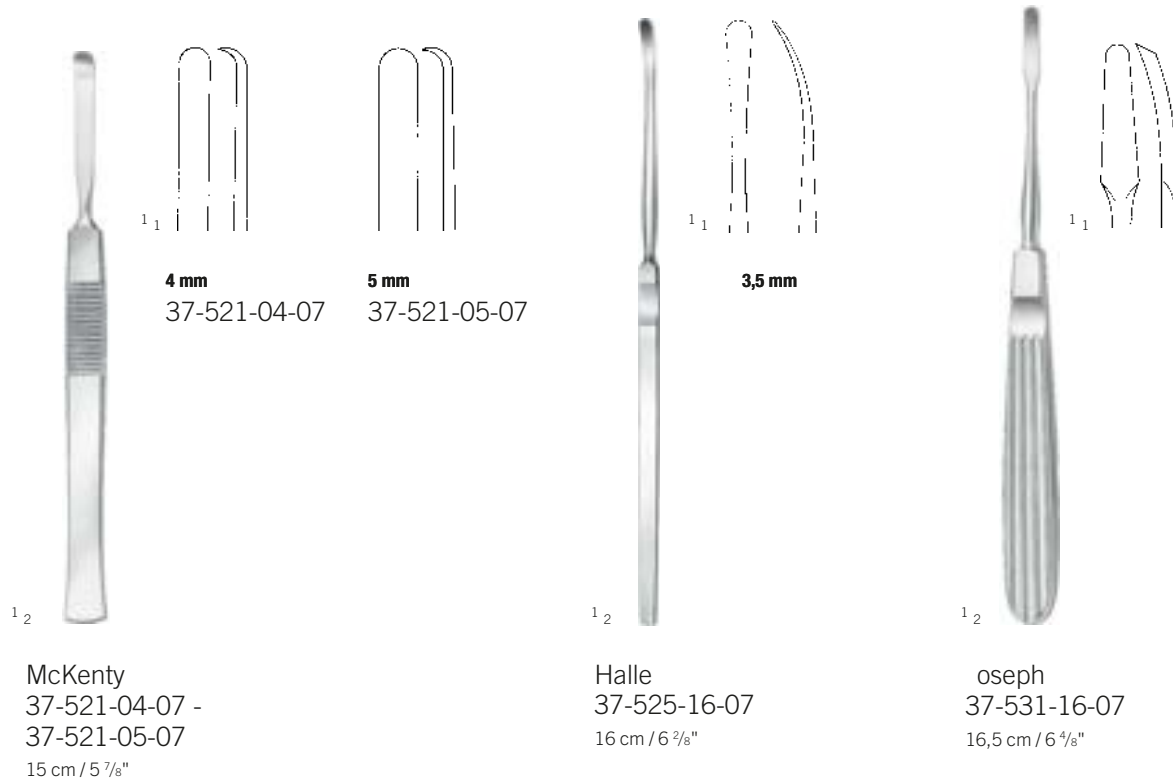
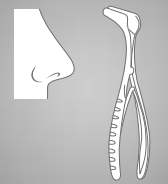

4 mm
37-521-04-07



5 mm
37-521-05-07



3,5 mm



oseph
37-531-16-07

McKenty
37-521-04-07 -
37-521-05-07
15 cm / 5 7/8"

Halle
37-525-16-07
16 cm / 6 1/8"

oseph
37-531-16-07
16,5 cm / 6 1/2"

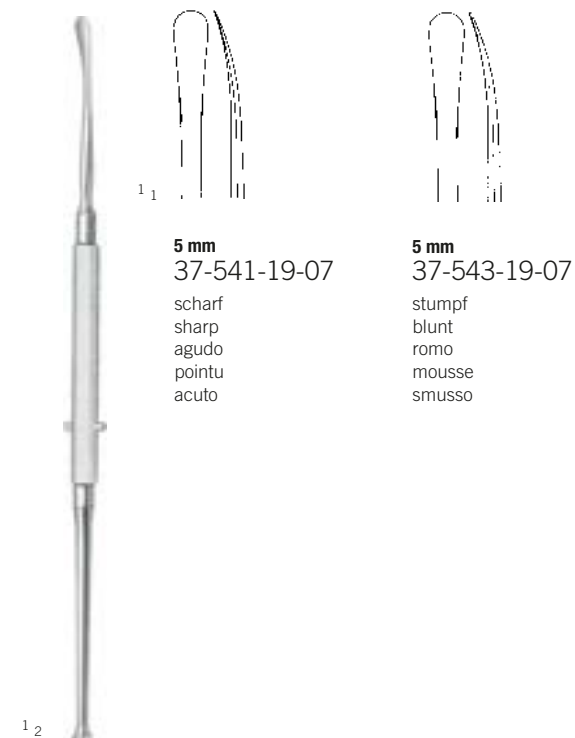

5 mm
37-541-19-07

scharf
sharp
agudo
pointu
acuto

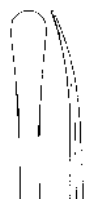

5 mm
37-543-19-07

stumpf
blunt
romo
mousse
smusso

Freer
37-541-19-07 -
37-543-19-07
19 cm / 7 1/2"

Septumlevatorien

Septum levators

levadores para tabique nasal

lévateurs pour la cloison nasale

levatori per il setto nasale

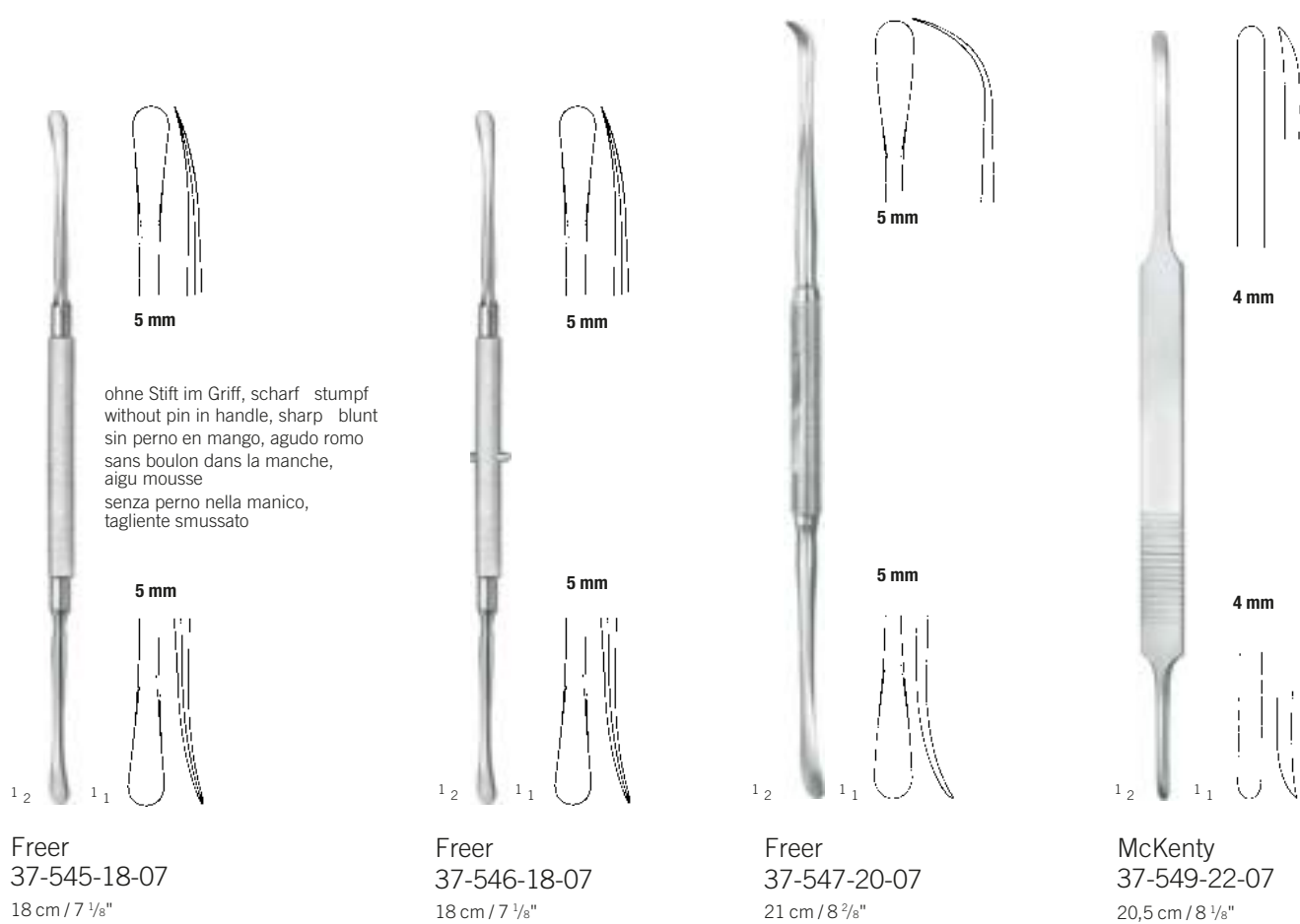

Septumlevatorien

Septum levators

levadores para tabique nasal

lévateurs pour la cloison nasale

levatori per il setto nasale

Rhinologie

Rhinology

Rinologia

Rhinologie

Rinologia

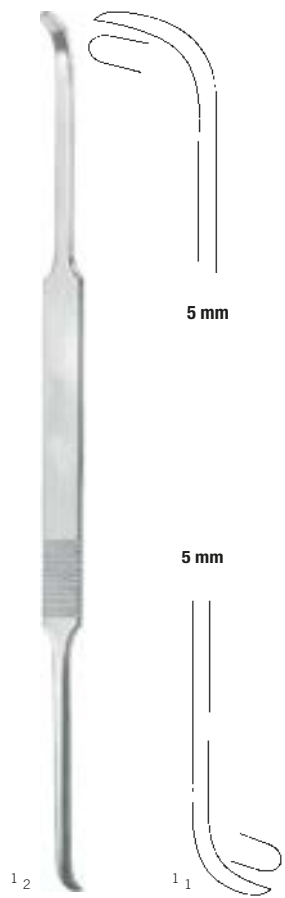
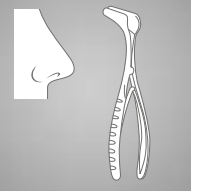

Cottle
37-559-23-07
23,5 cm / 9 2/8"



Killian
37-560-18-07
18 cm / 7 1/8"



Killian
37-562-22-07
23,5 cm / 9 2/8"

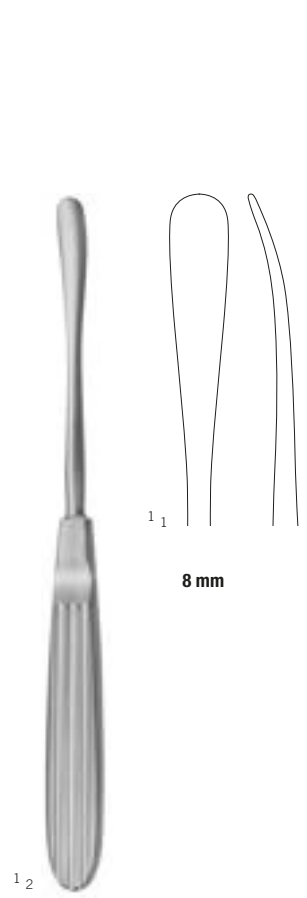

Cottle
37-566-18-07
18 cm / 7 1/8"

Periostelevatorien

Periosteal levators
 Legras para periostio
 levateurs pour le périoste
 levatori per il periostio

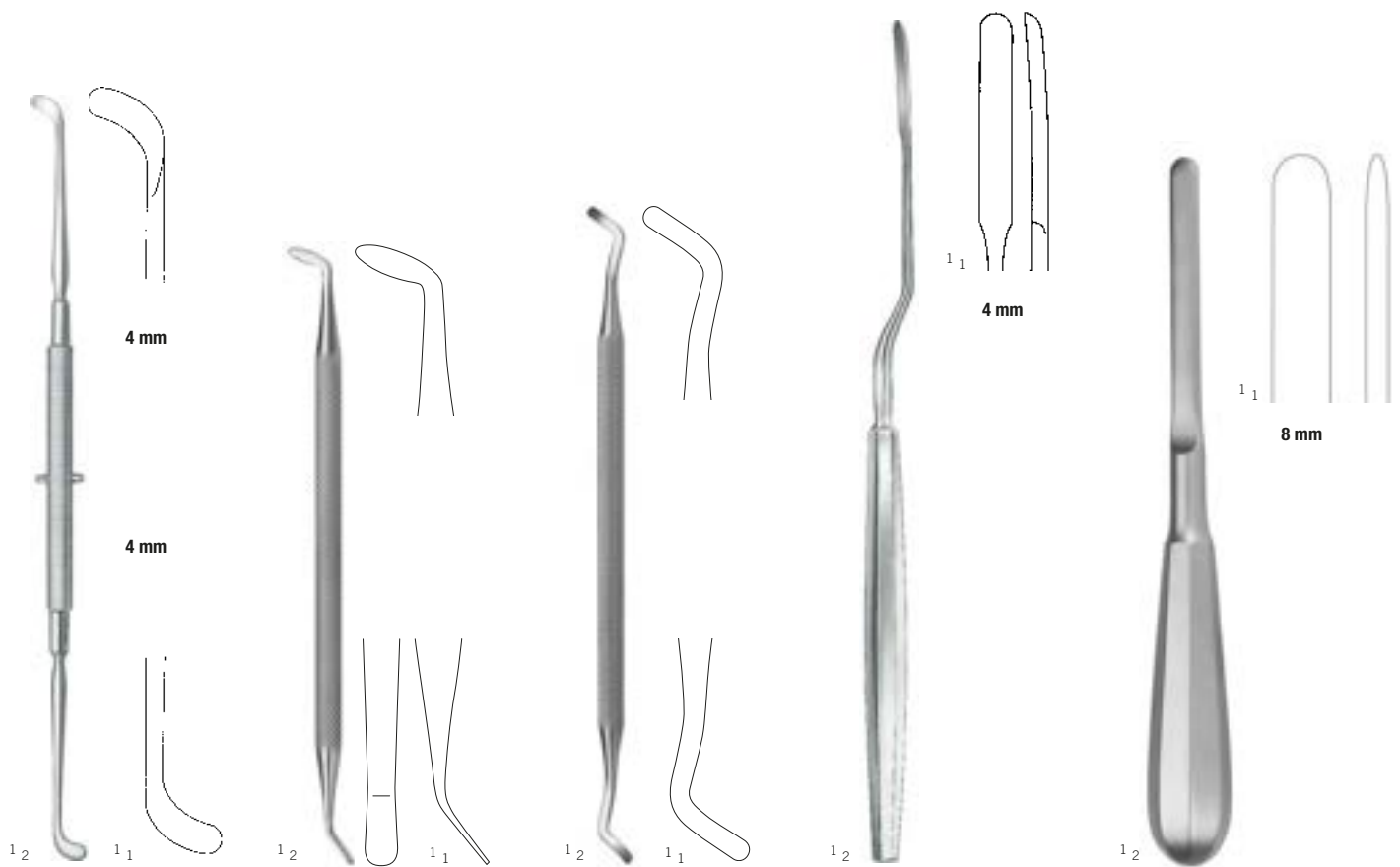

Pennington
 37-568-21-07
 21,5 cm / 8 4/8"

Nagata
 37-570-16-07

16 cm / 6 2/8"
 Elevatorium, Septum
 Elevator, septum
 Elevador, septum
 Élévateur, septum
 Elevatore, setto

Nagata
 37-570-17-07

17 cm / 6 5/8"
 Elevatorium, Septum
 Elevator, septum
 Elevador, septum
 Élévateur, septum
 Elevatore, setto

Joseph-Masing
 37-579-22-07

21,5 cm / 8 4/8"

Boies
 37-580-19-07

19 cm / 7 4/8"

Periostelevatorien

Periosteal levators

Legras para periostio

lévateurs pour le périoste

levatori per il periosto

Rhinologie

Rhinology

Rinologia

Rhinologie

Rinologia

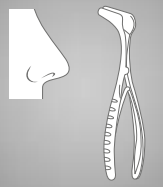

Cottle
37-581-22-07
23 cm / 9"



37-582-17-04
17 cm / 6 5/8"

AI

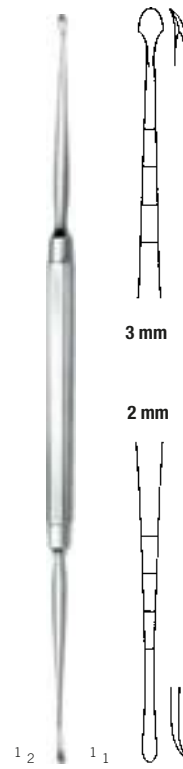

Masing
37-583-21-07
19,5 cm / 7 5/8"

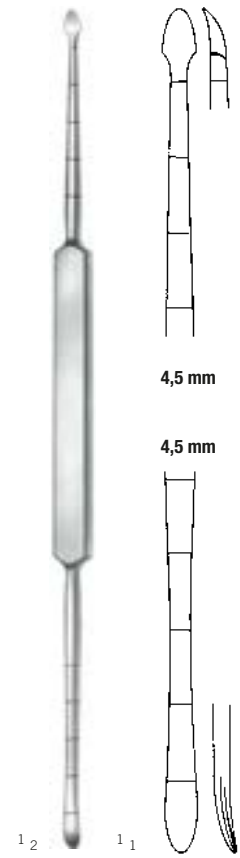

Cottle
37-584-21-07
22 cm / 8 5/8"

Septummeißel, Septum-Hohlmeißel

Septum Chisels, Septum Gouges

Cinceles para tabique nasal, Gubias para tabique nasal

lévateurs pour le périoste, Gouges pour la cloison nasale

levatori per il periosto, Sgorbie per il setto nasale

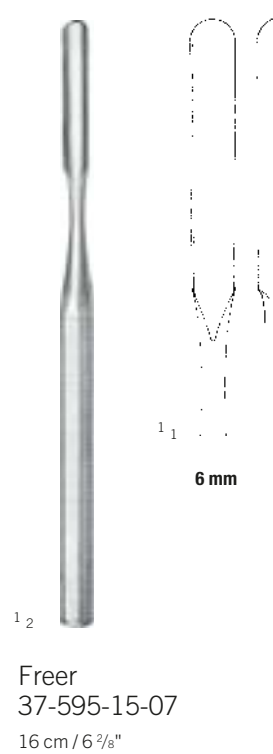
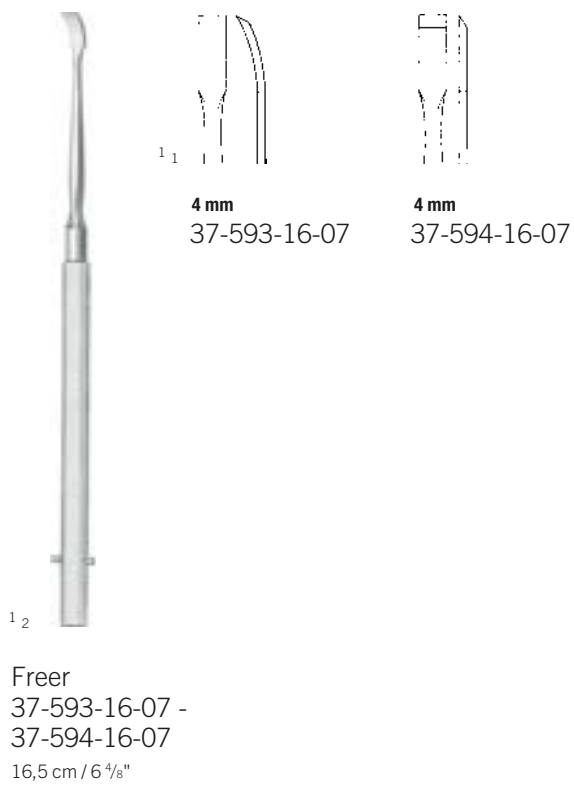

Septum-Hohlmeißel

Septum Gouges

Gubias para tabique nasal

Gouges pour la cloison nasale

Sgorbie per il setto nasale

Rhinologie

Rhinology

Rinologia

Rhinologie

Rinologia

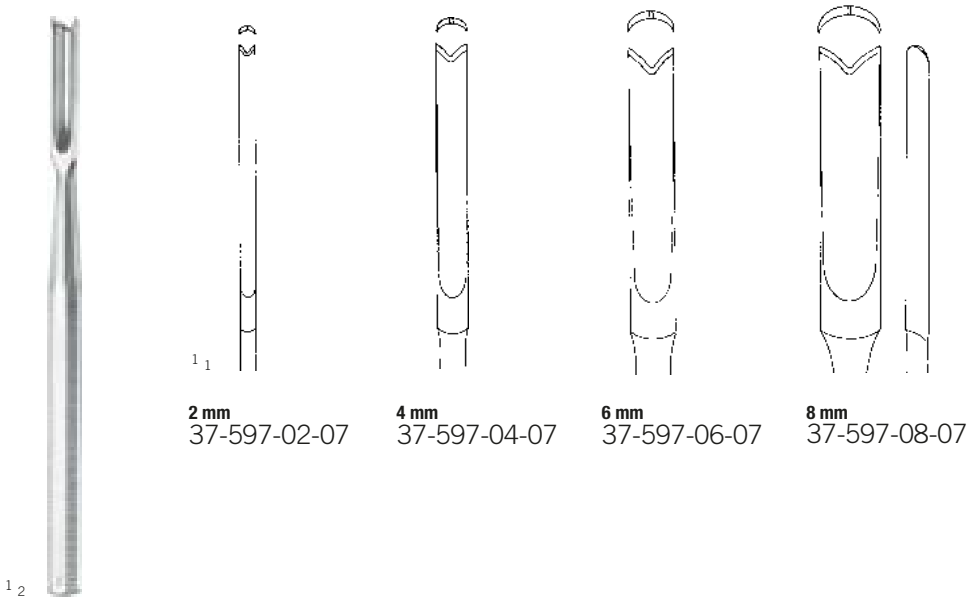
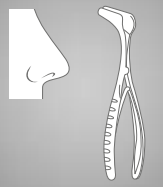

Ballenger
37-597-02-07 -
37-597-08-07
15 cm / 5 7/8"

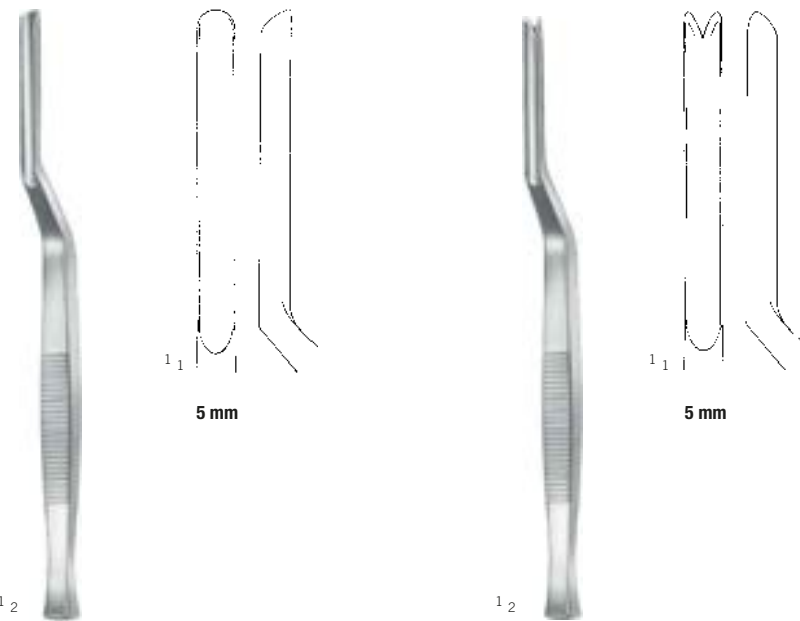

Killian
37-601-16-07
16 cm / 6 2/8"

Killian-Claus
37-605-16-07
16 cm / 6 2/8"

Osteotome

Osteotomes

Osteótomos

Ostéotomes

Osteotomi

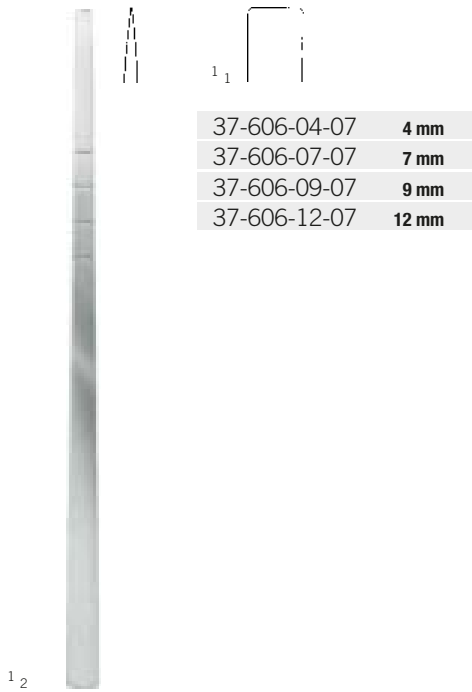

Cottle
37-606-04-07 -
37-606-12-07
18,5 cm / 7 2/8"



Cottle
37-607-06-07
18,5 cm / 7 2/8"

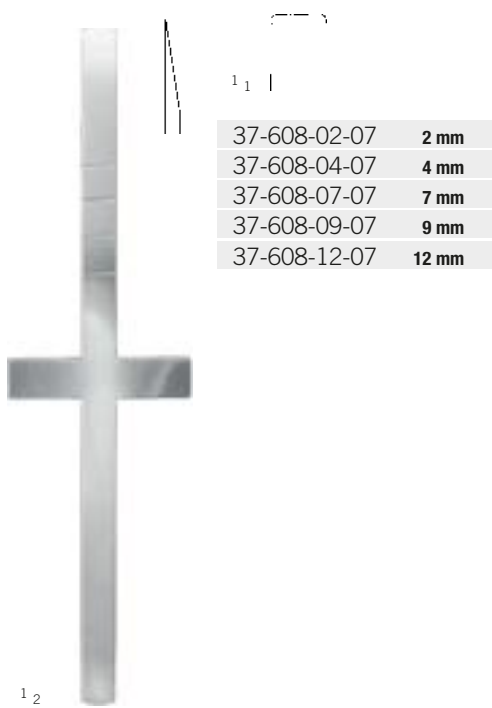

Cottle
37-608-02-07 -
37-608-12-07
18,5 cm / 7 2/8"

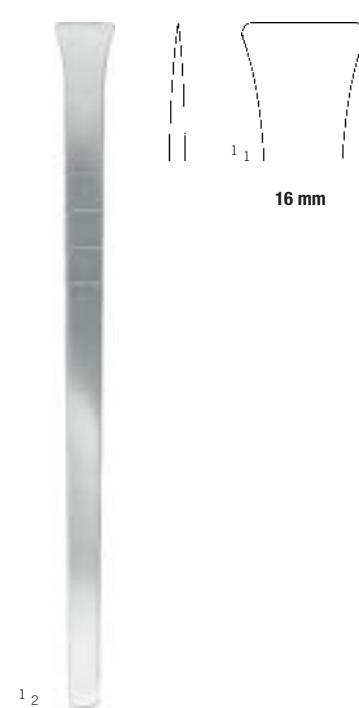

Cottle
37-610-16-07
18,5 cm / 7 2/8"

Osteotome, Meißel

Osteotomes, Chisels
 Osteótomos, Cinceles
 Ostéotomes, Ciseaux-burins
 Osteotomi, Scalpelli

Rhinologie

Rhinology
 Rinología
 Rhinologie
 Rinologia

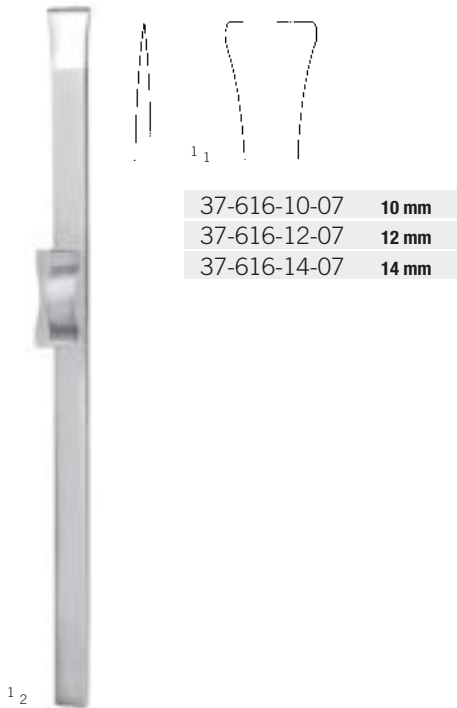
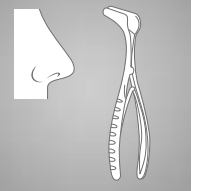

37-616-10-07	10 mm
37-616-12-07	12 mm
37-616-14-07	14 mm

Rubin
 37-616-10-07 -
 37-616-14-07
 18,5 cm / 7 7/8"

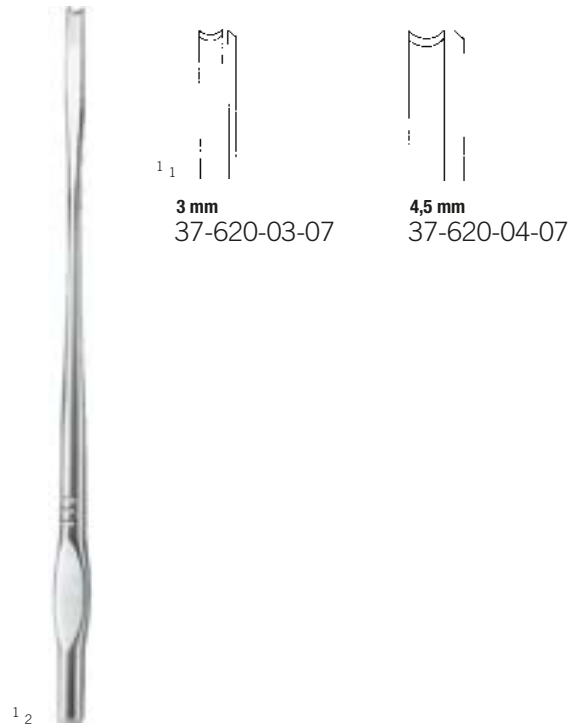

37-620-03-07	3 mm
37-620-04-07	4,5 mm

Walter
 37-620-03-07 -
 37-620-04-07
 19 cm / 7 7/8"

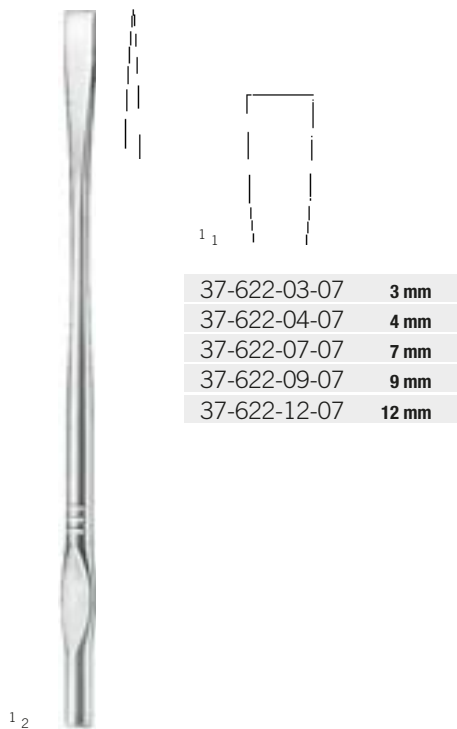

37-622-03-07	3 mm
37-622-04-07	4 mm
37-622-07-07	7 mm
37-622-09-07	9 mm
37-622-12-07	12 mm

Walter
 37-622-03-07 -
 37-622-12-07
 19 cm / 7 7/8"

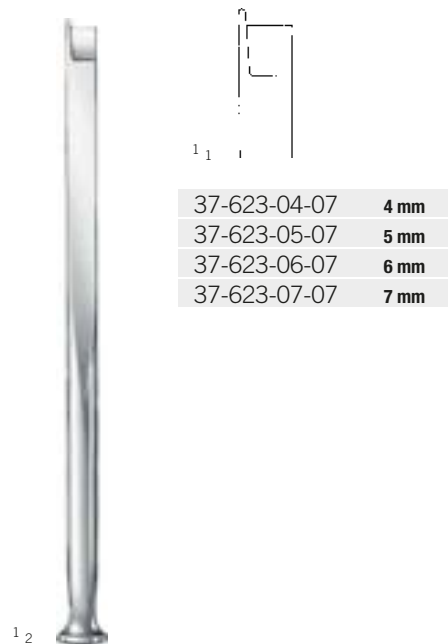

37-623-04-07	4 mm
37-623-05-07	5 mm
37-623-06-07	6 mm
37-623-07-07	7 mm

Fomon
 37-623-04-07 -
 37-623-07-07
 16 cm / 6 3/8"

Nasenmeißel, Meißel

Rhinoplastic Chisels, Chisels

Cinceles nasales, Cinceles

Ciseaux-burins nasaux, Ciseaux-burins

Scalpelli nasali, Scalpelli



Cinelli
37-624-10-07 -
37-624-16-07
16 cm / 6 1/8"



37-627-03-04
18,5 cm / 7 3/8"

AI

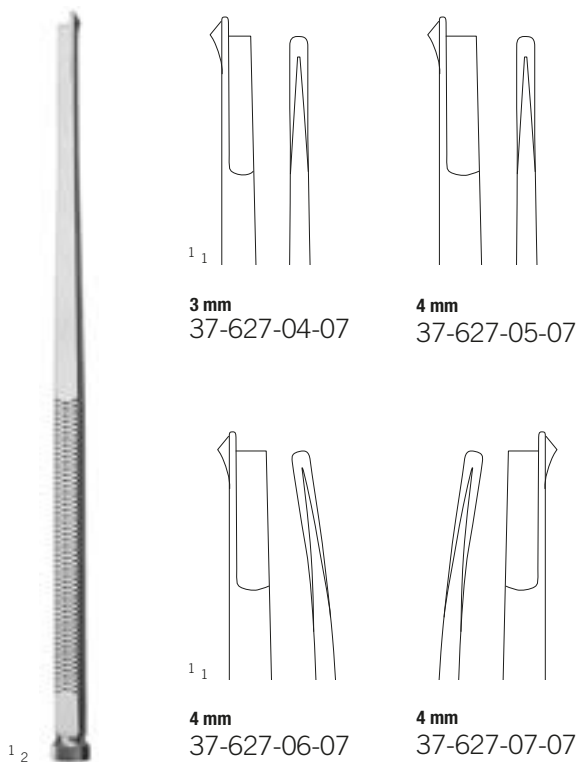

Fanous
37-627-04-07
37-627-07-07
19,5 cm / 7 5/8"



Walter
37-627-08-07
19 cm / 7 4/8"

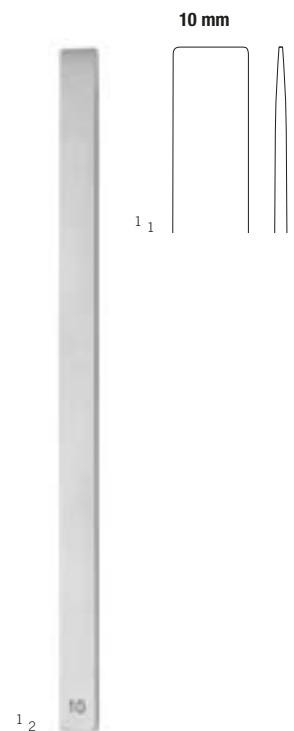

Walter
37-627-10-07
20 cm / 7 7/8"

Nasenmeißel, Meißel

Rhinoplastic Chisels, Chisels

Cinceles nasales, Cinceles

Ciseaux-burins nasaux, Ciseaux-burins

Scalpelli nasali, Scalpelli

Rhinologie

Rhinology

Rinologia

Rhinologie

Rinologia

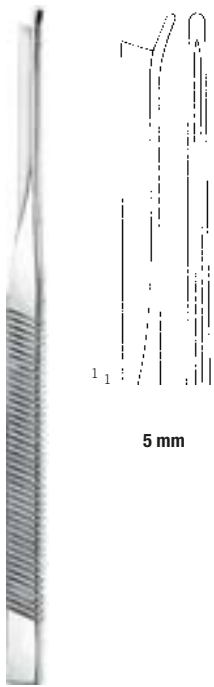
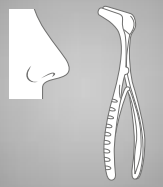

5 mm

1 2

Silver
37-628-01-07
18 cm / 7 1/8"

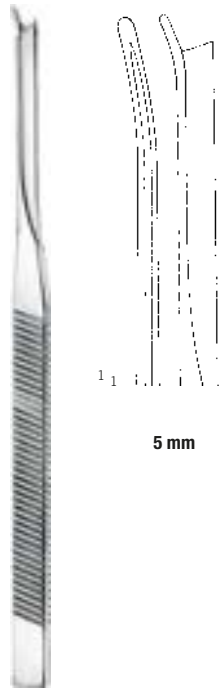

5 mm

1 2

Silver
37-628-02-07
18 cm / 7 1/8"

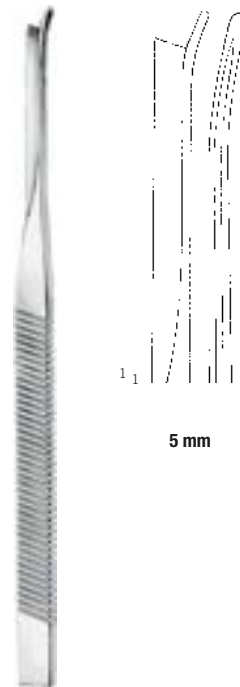

5 mm

1 2

Silver
37-628-03-07
18 cm / 7 1/8"

Nasensägen

Nasal Saws
Sierras nasales
Scies nasales
Seghe nasali

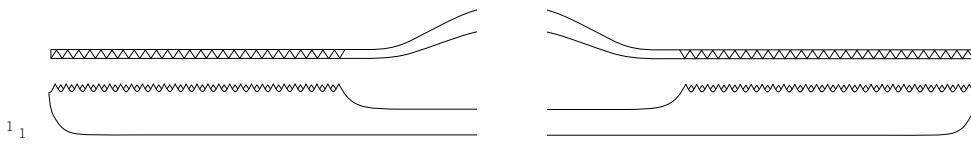

links abgewinkelt
angled to left
angulada por izquierda
coudée vers gauche
angulata a sinistra

1_2

oseph
37-632-20-07
17 cm / 6 5/8"



rechts abgewinkelt
angled to right
angulada por derecha
coudée vers droite
angulata a destra

1_2

oseph
37-634-20-07
17 cm / 6 5/8"



1_2

oseph
37-649-00-07 -
37-649-02-07
19 cm / 7 1/8"

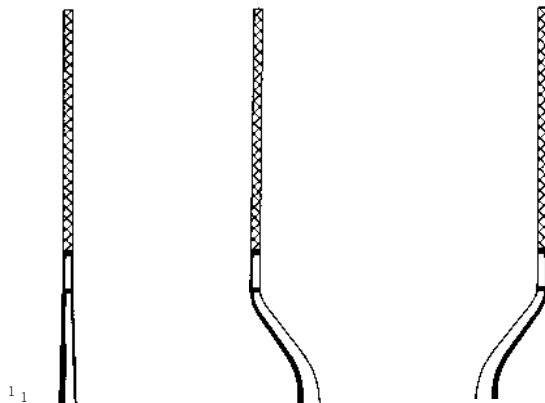

1_1

37-649-00-07
Arbeitslänge
working length
largo til
longueur utile
lunghezza utile
40 mm

37-649-01-07
Arbeitslänge
working length
largo til
longueur utile
lunghezza utile
40 mm

37-649-02-07
Arbeitslänge
working length
largo til
longueur utile
lunghezza utile
40 mm

Knorpelquetsche

Cartilage Crusher
Machacadora
Pinces-gouge cartilage
Torchio per cartilagine

Rhinologie

Rhinology
Rinologia
Rhinologie
Rinologia

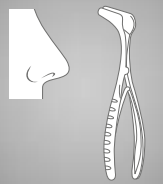

1 2

Cottle

37-652-00-07

Knorpelquetsche
Cartilage Crusher
Machacadora
Pinces-gouge cartilage
Torchio per cartilagine

65 x 30 x 30 mm



1 2

Gubisch

37-652-01-07

Knorpelquetsche
Cartilage Crusher
Machacadora
Pinces-gouge à cartilage
Torchio per cartilagine

65 x 30 x 30 mm



1 2

37-652-02-04

Schneideblock
Cutting block
Bloque de corte
Bloc de coupe
Blocco taglio

55 x 87 x 12 mm

Nasenraspeln, Knochenfeilen, Antrumraspeln

Nasal Rasps, Bone Files, Antrum Rasps

scofinas nasales, Limas para huesos, scofinas para el antro

R pes nasales, Limes os, R pes pour antre

Raspe nasali, Lime per ossa, Raspe per seno mascellare



1₂

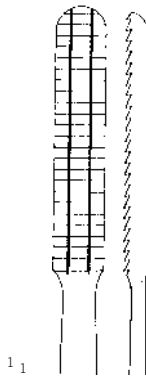

1₁

37-656-01-07

auf Zug schneidend
drawing cut
cortante a tracción
tranchante traction
tagliente a trazione

34 x 7 mm

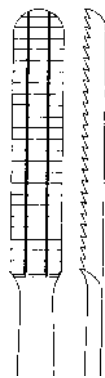

37-656-02-07

auf Stoss schneidend
pushing cut
cortante a empuje
tranchante impact
tagliente a urto

34 x 7 mm

Maltz
37-656-01-07 -
37-656-02-07
17 cm / 6 5/8"



1₂

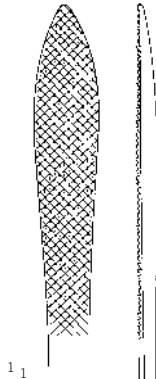

1₁

60 x 8 mm

Joseph
37-658-01-07
16 cm / 6 2/8"



1₂

Converse
37-669-18-04
18 cm / 7 1/8"



1₁

5 mm



1₂

Cottle
37-670-21-07
21 cm / 8 2/8"

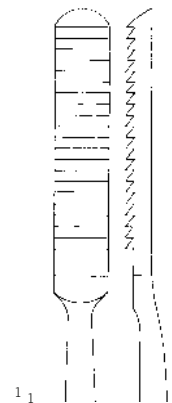

1₁

auf Zug schneidend
drawing cut
cortante a tracción
tranchante traction
tagliente a trazione

34 x 8 mm

AI

Glabellaraspeln, Nasenraspeln

Glabella Rasps, Nasal Rasps

scofinas para glabella, scofinas nasales

R pes pour la glabella, R pes nasales

Raspe per glabella, Raspe nasali

Rhinologie

Rhinology

Rinología

Rhinologie

Rinologia

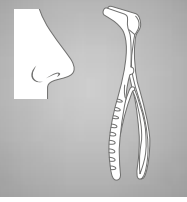

1₂

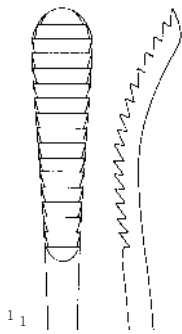

32 x 9 mm

37-671-21-07

auf Stoss schneidend
pushing cut
cortante a empuje
tranchante impact
tagliente a urto

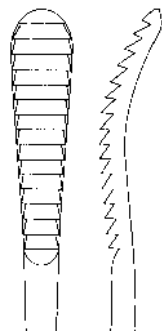

32 x 9 mm

37-673-21-07

auf Zug schneidend
drawing cut
cortante a tracción
tranchante traction
tagliente a trazione



1₂

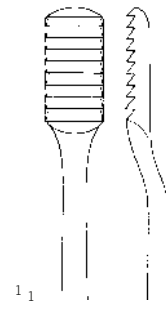

15 x 8 mm

37-674-18-07

auf Zug schneidend
drawing cut
cortante a tracción
tranchante traction
tagliente a trazione

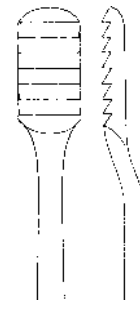

15 x 8 mm

37-676-18-07

auf Zug schneidend
drawing cut
cortante a tracción
tranchante traction
tagliente a trazione

feine Zahnung
delicate serration
dentado fina
denture fine
dentatura delicata

grobe Zahnung
coarse serration
dentado grueso
denture grossi re
dentatura grossolana

Aufricht

37-671-21-07 -

37-673-21-07

21 cm / 8 2/8"

Lewis

37-674-18-07 -

37-676-18-07

19 cm / 7 4/8"



1₂

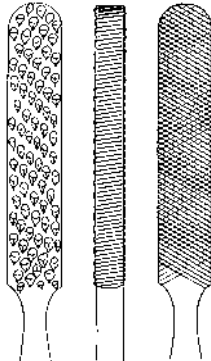

1₁

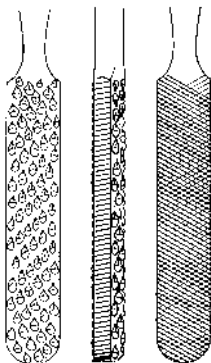

7,0 mm

Fomon

37-680-21-07

20,5 cm / 8 1/8"

Nasenraspeln

Nasal Rasps
scofinas nasales
R. pes nasales
Raspe nasali

TC GOLD

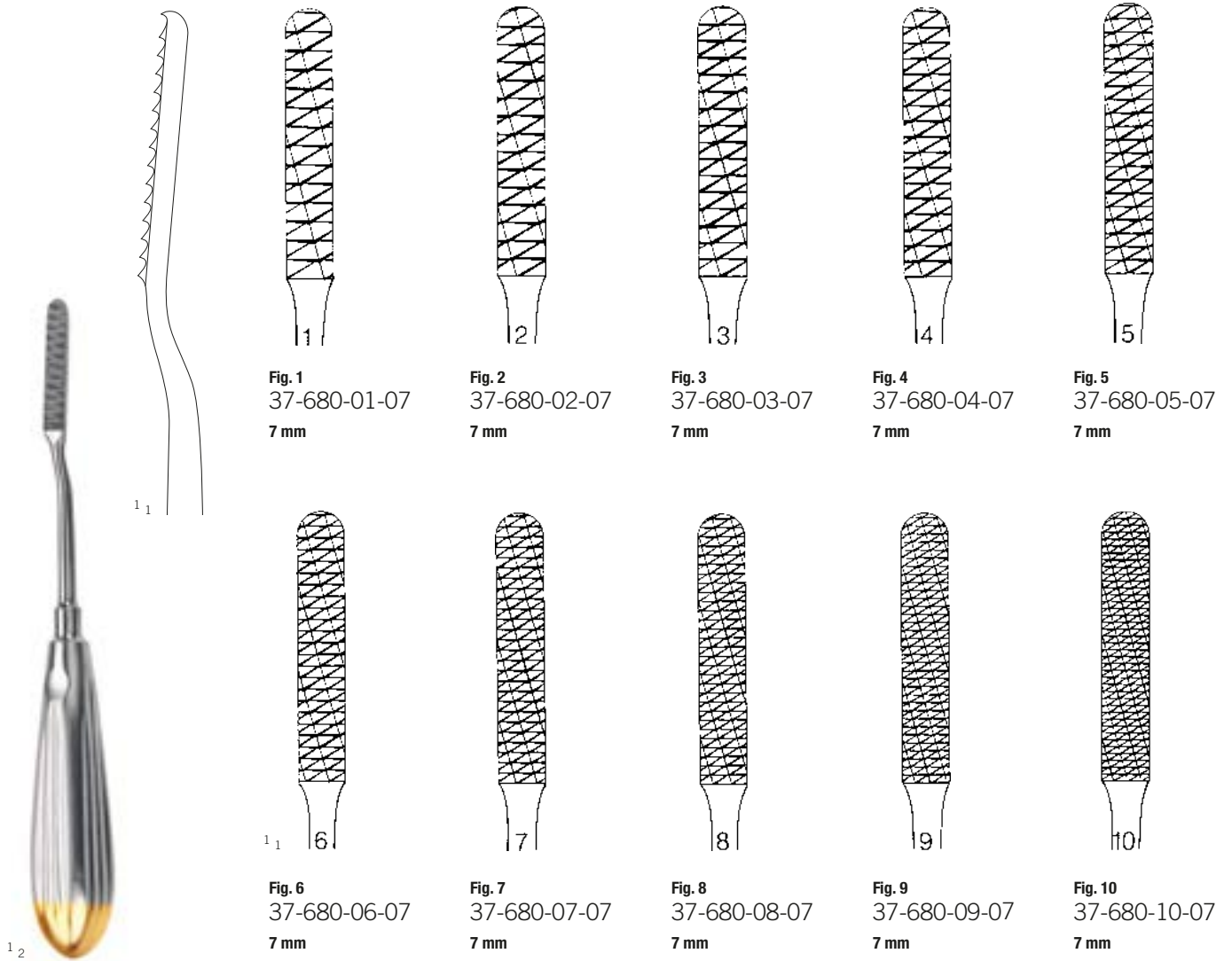

Maltz
37-680-01-07 -
37-680-10-07
21 cm / 8²/₈"

Nasenraspeln

Nasal Rasps
scofinas nasales
R pes nasales
Raspe nasali

Rhinologie

Rhinology
Rinología
Rhinologie
Rinologia

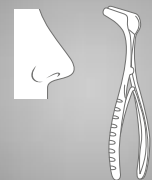

TC GOLD



1 2

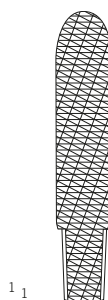

1 1

Fig. 1
37-681-01-07
7 mm



Fig. 2
37-681-02-07
7 mm



Fig. 3
37-681-03-07
7 mm

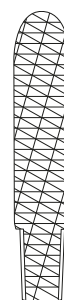

Fig. 4
37-681-04-07
7 mm

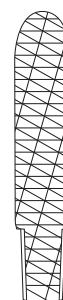

Fig. 5
37-681-05-07
7 mm

37-681-11-07

14 cm / 5 5/8"

Handgriff für TC-Raspeleinsatz
Handle for TC Inserts
Mango para escofina TC
Poignée pour insert de râpe CT
Manico per inserto raspa TC



1 2

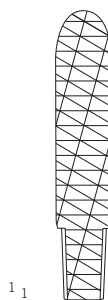

1 1

Fig. 6
37-681-06-07
7 mm

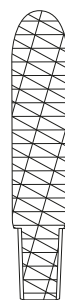

Fig. 7
37-681-07-07
7 mm



Fig. 8
37-681-08-07
7 mm



Fig. 9
37-681-09-07
7 mm



Fig. 10
37-681-10-07
7 mm



1 2

37-681-13-07

Schlüssel für Handgriff
Key for handle
Llave para mango
Clé pour poignée
Chiave per manico



37-681-11-07
37-681-12-07

37

Nasenraspeln

Nasal Rasps
scofinas nasales
R pes nasales
Raspe nasali

TC GOLD

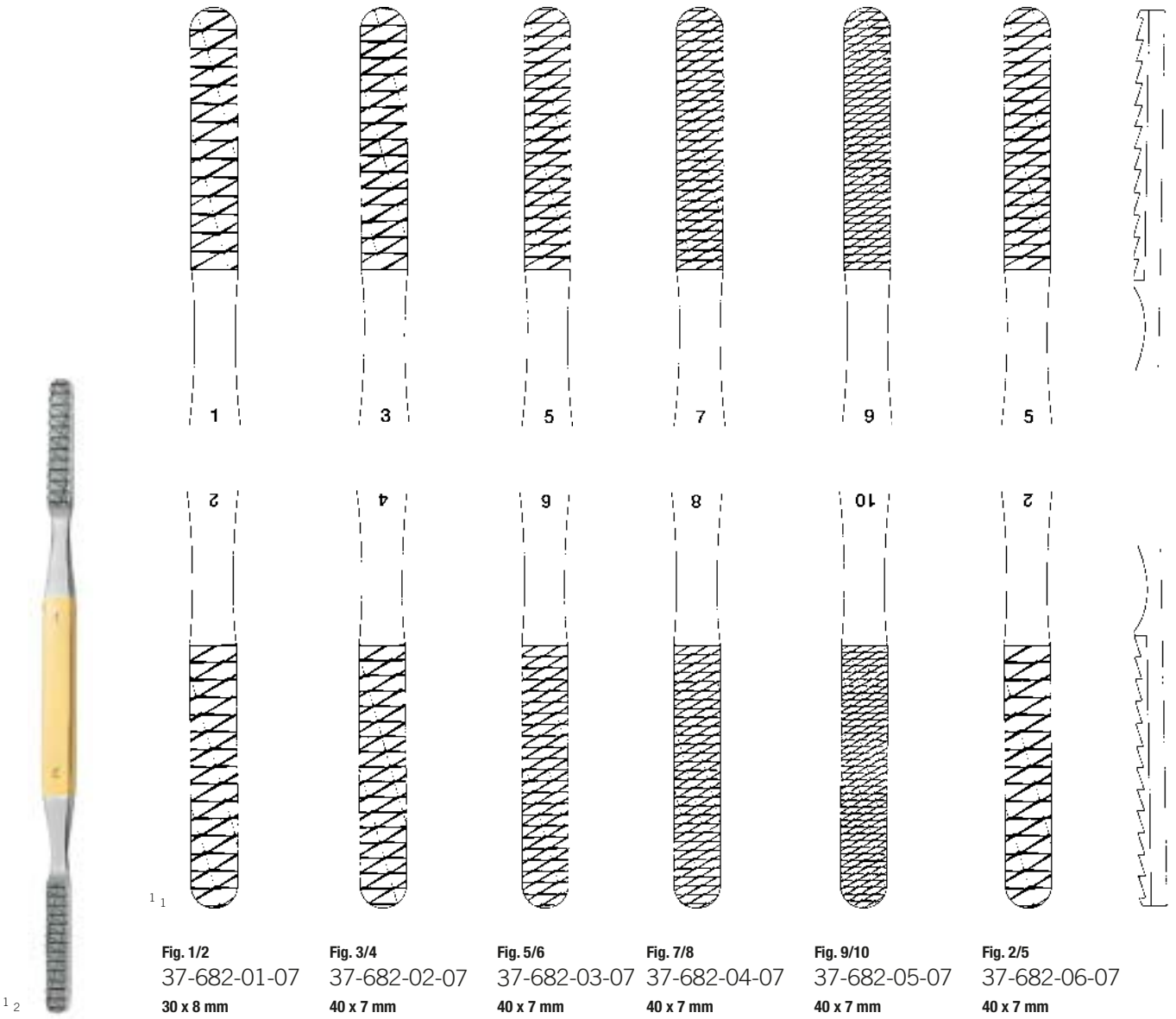

Fomon
37-682-01-07 -
37-682-06-07
20,5 cm / 8 1/8"

Nasenhäkchen

Nasal Hooklets
 Ganchitos nasales
 Crochets nasaux
 Uncini nasali

Rhinologie

Rhinology
 Rinologia
 Rinologie
 Rinologia

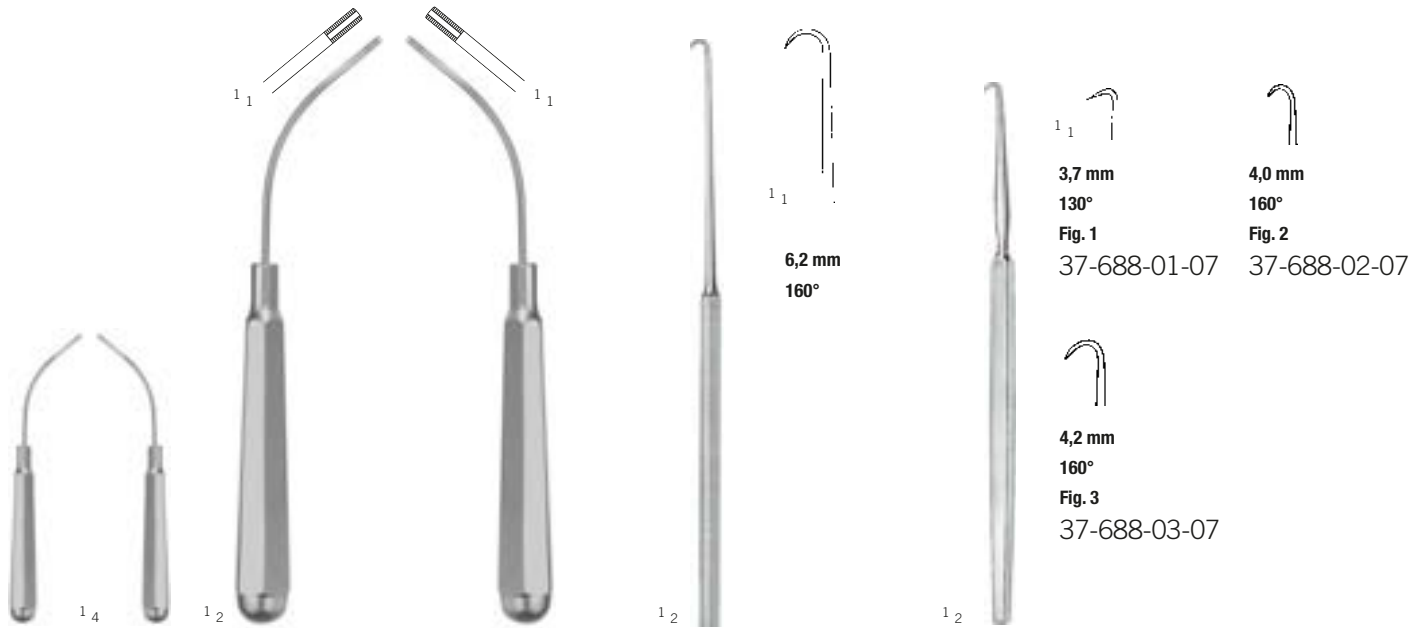
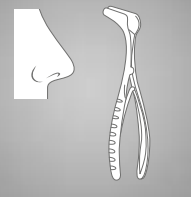

Fig. 1 - 2
Dingman
 37-683-00-07

15 cm / 5 7/8"

Knorpelschaber
 Raspatory, Cartilage
 Rascador cartilago
 Grattoir cartilage
 Raschiatore p.cart.

Fig. 1
Dingman
 37-683-01-07

15 cm / 5 7/8"

Knorpelschaber
 Raspatory, Cartilage
 Rascador cartilago
 Grattoir cartilage
 Raschiatore p.cart.

Fig. 2
Dingman
 37-683-02-07

15 cm / 5 7/8"

Knorpelschaber
 Raspatory, Cartilage
 Rascador cartilago
 Grattoir cartilage
 Raschiatore p.cart.

Joseph
 37-684-15-07

15,5 cm / 6 1/8"

Schleimhauth kchen, scharf
 Mucosa Hooklet, sharp
 Ganchito para mucosa, agudo
 Crochet pour la muqueuse, pointu
 Uncino per mucosa, acuto

Cottle
 37-688-01-07 - 37-688-03-07

14,5 cm / 5 5/8"

scharf
 sharp
 agudo
 pointu
 acuto



1_1

Ø 2 mm
 160°

Lange
 37-692-22-07

23 cm / 9"

Nasenflügelh kchen, Knopfende
 Alar Hooklet, button end
 Ganchito para alas de nariza, botonado
 Crochet pour les ailes du nez, boutonné
 Uncino per le pinne nasali, con fine a bottone

1_2



1_1

Ø 1,75 mm
 160°

Fomon
 37-694-17-07

17 cm / 6 5/8"

Nasenflügelh kchen, Knopfende
 Alar Hooklet, button end
 Ganchito para alas de nariza, botonado
 Crochet pour les ailes du nez, boutonné
 Uncino per le pinne nasali, con fine a bottone

1_2

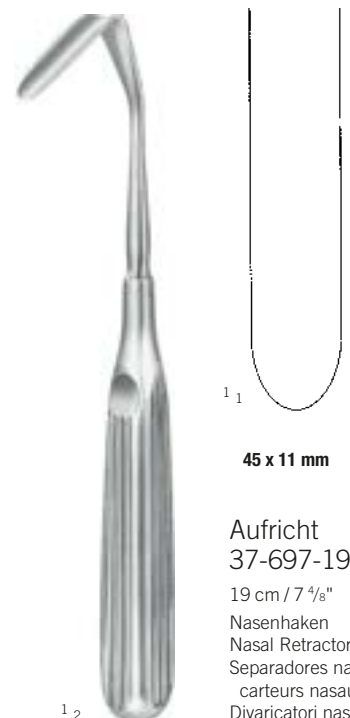

1_1

45 x 11 mm

Aufricht
 37-697-19-07

19 cm / 7 4/8"

Nasenhaken
 Nasal Retractors
 Separadores nasales
 carteurs nasaux
 Divaricatori nasali

1_2

Nasenflügelhäkchen, Schleimhauthäkchen

Alar Hooklets, Mucosa Hooklet

Ganchitos para alas de nariz, Ganchito para mucosa

Crochets pour les ailes du nez, Crochet pour la muqueuse

Uncini per le pinne nasali, Uncino per mucosa



1 2

Kilner
37-698-10-07

8 cm / 3 1/8"

scharf
sharp
agudo
pointu
acuto



1 2

Converse
37-700-12-07

11,5 cm / 4 5/8"

scharf
sharp
agudo
pointu
acuto



1 2

Freer
37-702-15-07

15 cm / 5 7/8"

scharf
sharp
agudo
pointu
acuto

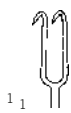

2 mm
37-704-02-07



5 mm
37-704-05-07

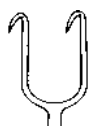

7 mm
37-704-07-07



10 mm
37-704-10-07

1 2

Josph
37-704-02-07 -
37-704-10-07

16 cm / 6 1/8"



1 2

Millard
37-705-01-07

5,5 cm

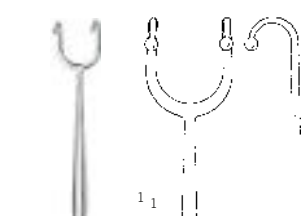

1 2

Fomon
37-706-16-07

16 cm / 6 2/8"

geknöpft
button ended
abotonado
boutonné
a bottone

Nasenflügelhäkchen, Nasenhaken

Alar Hooklets, Nasal Retractors

Ganchitos para alas de nariz, Separadores nasales

Crochets pour les ailes du nez, carteurs nasaux

Uncini per le pinne nasali, Divaricatori nasali

Rhinologie

Rhinology

Rinología

Rhinologie

Rinologia

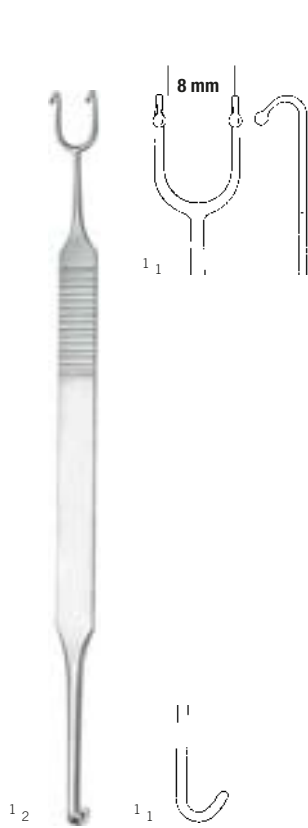
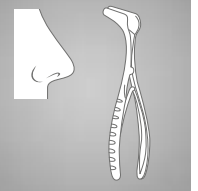

Cottle-Neivert
37-707-20-07
19,5 cm / 7 5/8"

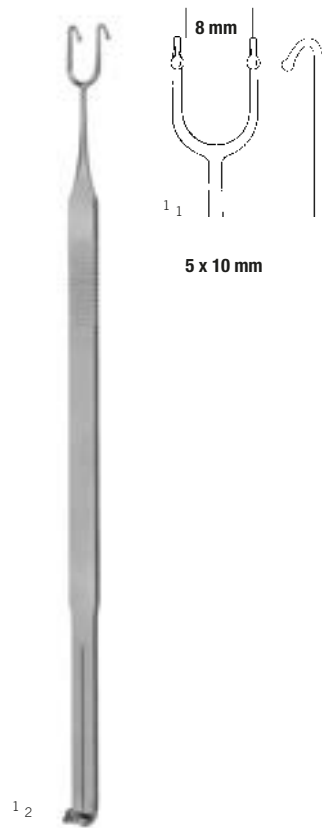

Cottle-Neivert
37-707-21-07
21 cm / 8 2/8"

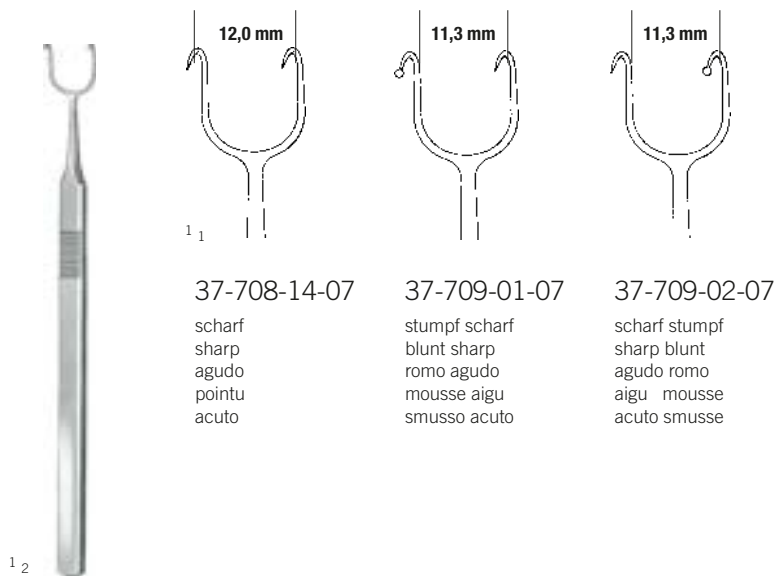

37-708-14-07

scharf
sharp
agudo
pointu
acuto

37-709-01-07

stumpf scharf
blunt sharp
romo agudo
mousse aigu
smusso acuto

37-709-02-07

scharf stumpf
sharp blunt
agudo romo
aigu mousse
acuto smusse

Cottle
37-708-14-07 -
37-709-02-07
14,5 cm / 5 6/8"

Nasenflügelhäkchen, Nasenhaken

Alar Hooklets, Nasal Retractors

Ganchitos para alas de nariz, Separadores nasales

Crochets pour les ailes du nez, carteurs nasaux

Uncini per le pinne nasali, Divaricatori nasali

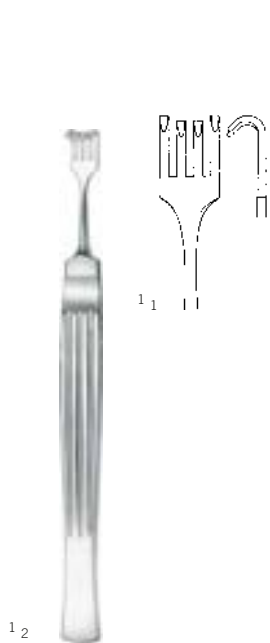

7,8 mm
Cottle
37-710-14-07
14 cm / 5 4/8"



13,7 mm
Neivert
37-712-16-07
17 cm / 6 5/8"



12,5 mm
Cottle
37-713-15-07
14 cm / 5 4/8"
Sattelhäkchen
Saddle Hook
Separador en forma de silla
lévateur sous forme de selle
levatori in forma di sella



13,0 mm
Cottle
37-714-15-07
16 cm / 6 2/8"



Blunter
blades
hojas
lames
lame
60 x 6,5 mm

Aufricht
37-715-14-07
12 cm / 4 6/8"
stumpf
blunt
romo
mousse
smusso

Septumzangen, Septumrichtzangen

Septum Forceps, Septum Straightening Forceps

Pinzas para tabique nasal, Pinzas para enderezar el tabique nasal

Pinces pour la cloison nasale, Pinces pour le redressement de la cloison nasale

Pinze per il setto nasale, Pinze per raddizzare il setto nasale

Rhinologie

Rhinology

Rinología

Rhinologie

Rinologia

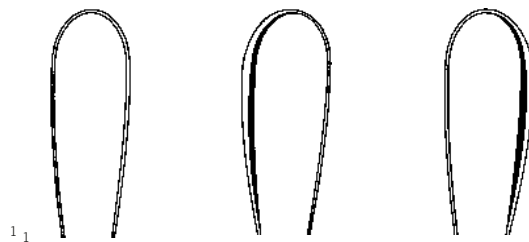
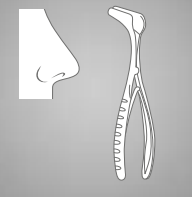

1₁

37-724-01-07

gerade
straight
recta
droite
diritta

37-724-02-07

links
left
izquierdo
gauche
sinistra

37-724-03-07

rechts
right
derecho
droit
destra



1₂

Kressner
37-721-20-07
22 cm / 8 5/8"



1₂

Cottle-Walsham
37-724-01-07 -
37-724-03-07
23 cm / 9"

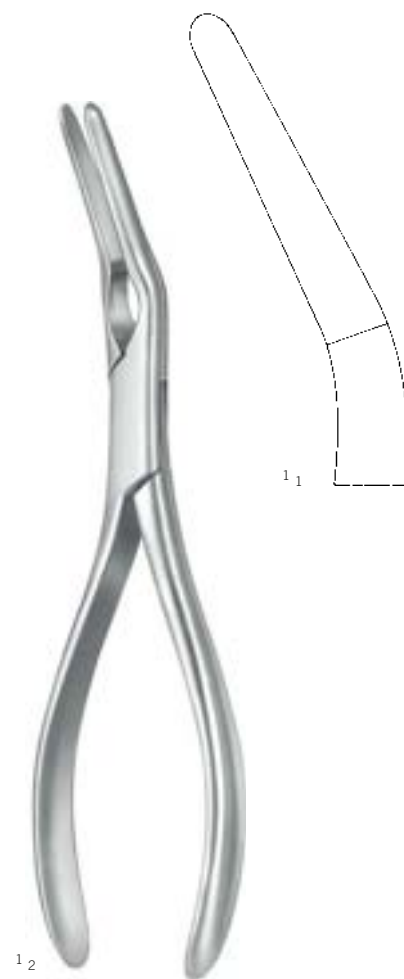

1₂

Asch
37-725-23-07
22,5 cm / 8 7/8"

1₁

Hautfasspinzetten, Antrumküretten

Skin Grasping Forceps, Antrum Curettes

Pinzas para piel, Curetas para el antro

Pinces pour saisir la peau, Curettes pour l'antro

Pinze per afferrare la pelle, Curette per antro

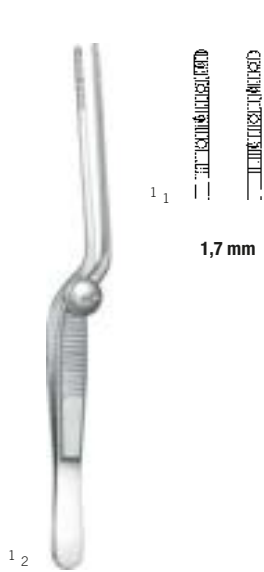

Cottle
37-731-14-07

14 cm / 5 1/2"
mit Zähnen
with teeth
con dientes
avec dents
con denti

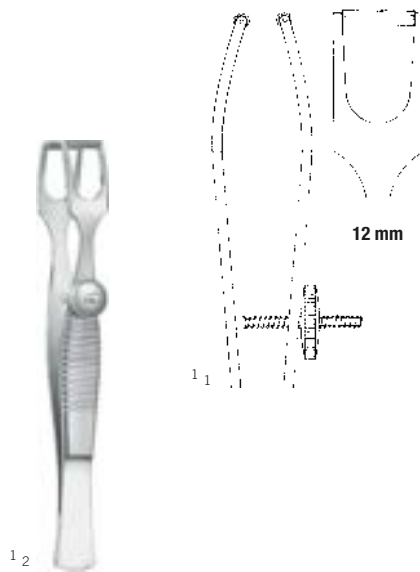

Cottle
37-732-10-07

11 cm / 4 3/8"
Columellapinzette
Columella Forceps
Pinza para columela
Pince à columella
Pinza per columella



Coakley
37-748-01-07 -
37-748-06-07

17 cm / 6 5/8"



Fig. 1
37-748-01-07



Fig. 2
37-748-02-07



Fig. 3
37-748-03-07



Fig. 4
37-748-04-07



Fig. 5
37-748-05-07



Fig. 6
37-748-06-07

Ringmesser

Adenoid Currettes
 Cuchillos para adenoides
 Couteaux végétations adeno dales
 Coltelli per vegetazioni adenoidee

Rhinologie

Rhinology
 Rinologia
 Rhinologie
 Rinologia

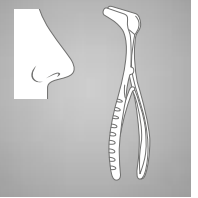

1₁

Fig. 1	37-755-01-07	13 mm
Fig. 2	37-755-02-07	15 mm
Fig. 3	37-755-03-07	17 mm
Fig. 4	37-755-04-07	19 mm
Fig. 5	37-755-05-07	21 mm
Fig. 6	37-755-06-07	23 mm

1₂

Beckmann
 37-755-01-07 -
 37-755-06-07
 22 cm / 8 5/8"

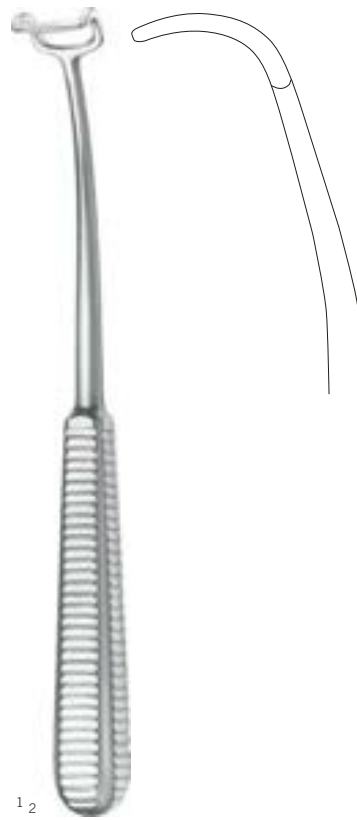

1₁

Fig. 1	37-756-01-07	13 mm
Fig. 2	37-756-02-07	15 mm
Fig. 3	37-756-03-07	17 mm
Fig. 4	37-756-04-07	19 mm
Fig. 5	37-756-05-07	21 mm
Fig. 6	37-756-06-07	23 mm

1₂

Beckmann
 37-756-01-07 -
 37-756-06-07
 21,5 cm / 8 1/2"

Saugraspatorium, Sinus-Dilatatoren

Suction Raspatory, Frontal Sinus Dilators

Legra de succión, Dilatadores para el seno

Rugine-raspatoire - succion, Dilatateurs pour le sinus frontal

Raspatorio con aspiratore, Dilatatori per il seno frontale

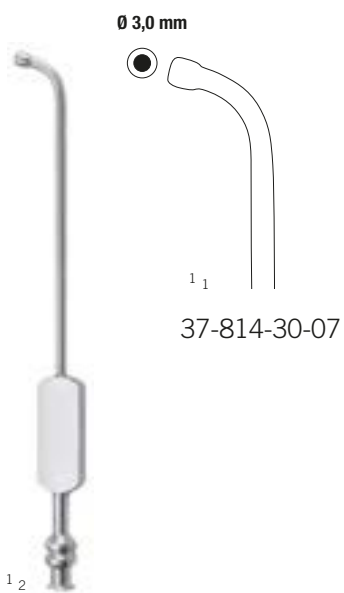

Ø 3,0 mm

37-814-30-07

1_2

Iicken-Killian
37-814-30-07 -
37-816-30-07 -
14 cm / 5 4/8"

Spülkanüle, mit Luer-Lock
Irrigation Cannula, with Luer-Lock
Sonda irrigadora para seno maxilar, con Luer-Lock
Canule à irrigation, avec Luer-Lock
Cannula per lavaggio, con Luer-Lock

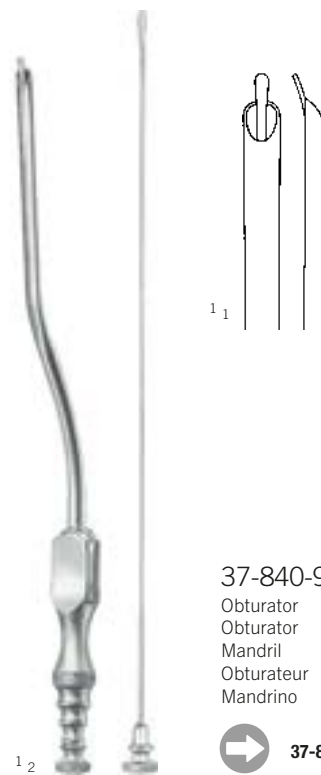

1_1

37-840-90-98

Obturator
Obturator
Mandril
Obturateur
Mandrino



37-840-20-01

1_2

Guilen
37-840-20-01
19 cm / 7 4/8"

Kranio-Maxillofaziale Chirurgie
Cranio-Maxillo-Facial Surgery
Cirugía craneo-maxilofacial
Chirurgie du crâne et maxillo-faciale
Chirurgia cranio-maxillo-facciale

38-52



Knochenquetsche

Bone crusher

Aplastador óseo

Presse d'os

Strumento per schiacciamento ossa

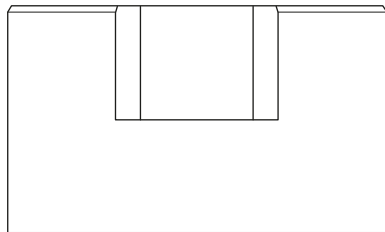
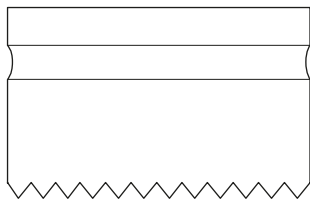
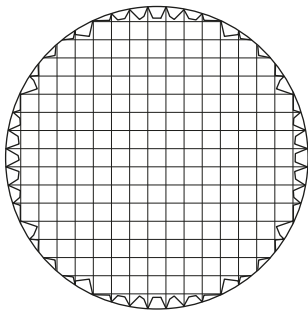

1₁



1₂

38-018-01-07

Mundkeile

Mouth Gags
Abrebocas
Ba llons
Apribocca

Mund-, Kiefer- und Gesichtschirurgie

Oral Maxillo-facial Surgery
Cirugía oral y maxilofacial
Chirurgie buccale et maxillo-faciale
Chirurgia maxillo-facciale



1 1

McKesson

kunststoffbeschichteter Metallrahmen
ohne Kette
plastic coated metal frame
without chain
cuadro metálico, cubierto de plástico
sin cadena
cadre métal avec rev tement synthétique
sans chaîne
telaio metallico, ricoperto in plastica
senza catena

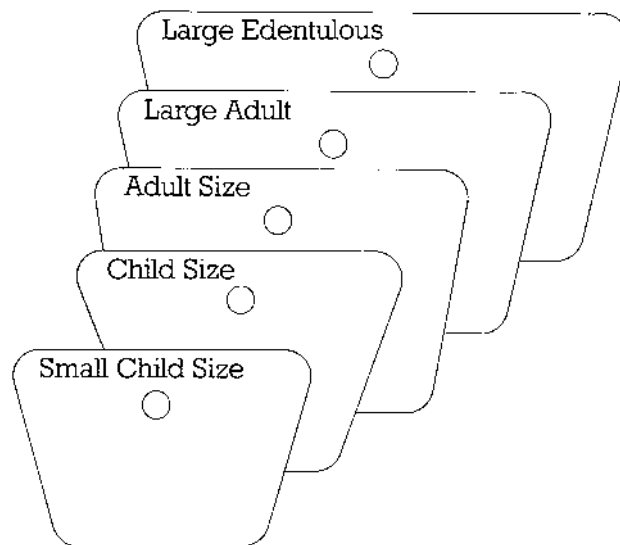

38-130-52-07

gro , für erwachsene
large, for adults
grande, para adultos
grand, pour adultes
grande, per adulti

38-130-56-07

klein, für Kinder
small, for children
peque o, para niños
petit, pour enfants
piccolo, per bambini

38-130-50-07

extra gro , für Zahnlose
extra large, for edentulous
muy grande, para desdentados
tr s grand, pour édentées
molto grande, per sdentati

38-130-54-07

normal, für erwachsene
regular, for adults
regular, para adultos
regulier, pour adultes
regolare, per adulti

38-130-58-07

klein, für Kleinkinder
small, for babies
peque o, para bebés
petit, pour bébés
piccolo, per neonati

Mundsperrer

Mouth Gags

Abrebocas

Ouvre-bouche

Apribocca



1₂

38-161-92-98
 Ersatzgummi
 Spare Rubber
 Goma de repuesto
 Caoutchouc de remplacement
 Gomma di ricambio



38-161-11-07

Molt
 38-161-11-07
 11 cm 4³/₈



1₂

38-161-93-98
 Ersatzgummi
 Spare Rubber
 Goma de repuesto
 Caoutchouc de remplacement
 Gomma di ricambio



38-161-14-07

Molt
 38-161-14-07
 13 cm 5¹/₈



1₂

Denhart
 38-171-12-07
 13 cm 5¹/₈

Backen
 jaws
 bocas
 mors
 branche
16 mm



1₂

Roser-König
 38-179-16-07 -
 38-179-20-07

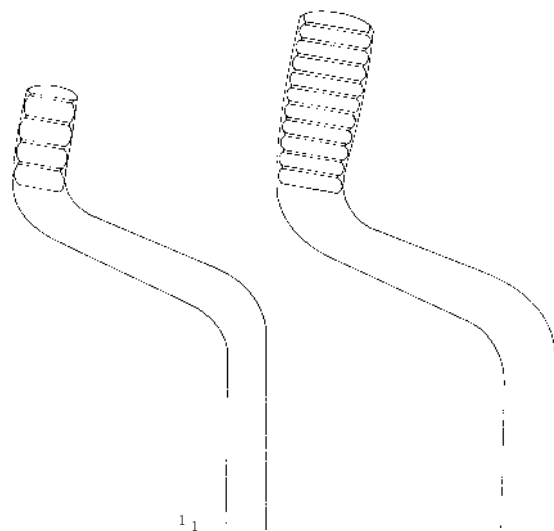

1₁

38-179-16-07
 16 cm 6²/₈

38-179-20-07
 19 cm 7⁴/₈

Mundsperrer

Mouth Gags
Abrebocas
Ouvre-bouche
Apribocca

Mund-, Kiefer- und Gesichtschirurgie

Oral Maxillo-facial Surgery
Cirugía oral y maxilofacial
Chirurgie buccale et maxillo-faciale
Chirurgia maxillo-facciale



38-198-90-98

Gaumenplatte
Palate Plate
Plaquita paldia
Plaque platine
Placca per palato

1 2

Kilner-Doughty 38-198-00-07

komplett mit Rahmen, 3 Zungenspatel, 2 Zahnplatten und 1 Gaumenplatte
complete, with frame, 3 tongue depressors, 2 toothplates and 1 palate plate
completo con bastidor, 3 bajalenguas, 2 plaquitas de dientes y 1 plaquita paldia
complet avec cadre, 3 abaisse-langue, 2 plaques pour dents e 1 plaque palatine
completo, con telaio, 3 abassalingua, 2 placche per denti e 1 placca per palato

Kilner-Doughty 38-198-10-07

14,5 cm 5 6 8
Mundsperrer-Rahmen
Frame for Mouth Gag
Bastidor para abreboca
Cadre pour ouvre-bouche
Telaio per apribocca

➔ 38-198-00-07

Kilner-Doughty 38-198-01-07 - 38-198-03-07

Zungendrucker
Tongue Depressor
Bajalengua
Abaisse-langue
Abassalingua



1 2

gefenestertes Blatt für Absaugung
fenestrated blade for suction
hoja fenestrada para succión
lame fen trée pour aspiration
lama con finestra per aspirazione

Fig. 1
38-198-01-07
68 x 30 mm

Fig. 2
38-198-02-07
77 x 34 mm

Fig. 3
38-198-03-07
82 x 39 mm

➔ 38-198-00-07

Mundsperrer

Mouth Gags
Abrebocas
Ouvre-bouche
Apribocca



Neukam
38-208-00-07

komplett mit Rahmen und 3 Zungenspateln
complete, with frame and 3 tongue depressors
completo con bastidor y 3 bajalenguas
complet avec cadre et 3 abaisse-langue
completo, con telaio e 3 abassalingua

Neukam
38-208-10-07

Mundsperrer-Rahmen, allein
Frame for Mouth Gag, only
Bastidor para abreboaca, suelto
Cadre pour ouvre-bouche, seul
Telaio per apribocca, solo



65 x 25,5 mm

73 x 28,5 mm

71 x 30,0 mm



38-208-01-07 -
38-208-03-07

Zungendrucker
Tongue Depressor
Bajalengua
Abaisse-langue
Abassalingua

gefenstrertes Blatt für Absaugung
fenestrated blade for suction
hoja fenestrada para succión
lame fen trée pour aspiration
lama con finestra per aspirazione

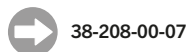

1 2

Fig. 1
38-208-01-07

Fig. 2
38-208-02-07

Fig. 3
38-208-03-07

Mundsperrer

Mouth Gags
Abrebocas
Ouvre-bouche
Apribocca

Mund-, Kiefer- und Gesichtschirurgie

Oral Maxillo-facial Surgery
Cirugía oral y maxilofacial
Chirurgie buccale et maxillo-faciale
Chirurgia maxillo-facciale



Mclvor
38-222-00-07

komplett, mit 3 Zungenspateln
complete, with 3 tongue depressors
completo, con 3 bajalenguas
complet, avec 3 abaisse-langue
completo, con 3 abassalingua

Mclvor
38-222-10-07

Mundsperrer-Rahmen
Frame for Mouth Gag
Bastidor para abrebocha
Cadre pour ouvre-bouche
Telaio per apribocca



38-222-00-07

Mclvor
38-222-01-07 -
38-222-03-07

Zungenspatel
Tongue Depressor
Bajalengua
Abaisse-langue
Abassalingua



38-222-00-07



Fig. 1
38-222-01-07
100 x 25 mm



Fig. 2
38-222-02-07
85 x 25 mm



Fig. 3
38-222-03-07
75 x 25 mm

Mundsperrer

Mouth Gags
Abrebocas
Ouvre-bouche
Apribocca



Dingmann
38-224-00-07

komplett mit Rahmen, 3 Zungenspateln
und 2 beweglichen Seitenvälven
complete, with frame, 3 tongue depressors
and 2 adjustable lateral blades
completo con bastidor, 3 bajalenguas
y 2 valvas laterales ajustables
complet avec cadre, 3 abaisse-langue
et 2 valves latérales réglables
completo, con telaio, 3 abassalingua
e 2 valve laterali movibili

Dingmann
38-224-01-07 -
38-224-03-07

Zungenspatel
Tongue Depressor
Bajalengua
Abaisse-langue
Abassalingua

➔ 38-224-00-07



Fig. 1
38-224-01-07
62 x 26 mm

Fig. 2
38-224-02-07
65 x 30 mm

Fig. 3
38-224-03-07
78 x 32 mm

Mundkeile

Mouth Gags
Abrebocas
Ba llons
Apribocca

Mund-, Kiefer- und Gesichtschirurgie

Oral Maxillo-facial Surgery
Cirugía oral y maxilofacial
Chirurgie buccale et maxillo-faciale
Chirurgia maxillo-facciale



1 2

Martin-Simplex
38-243-11-01
10,5 cm 4 1/8



1 2

38-246-14-04
14 cm 5 4/8
Vestibulumhaken
Vestibulum Retractor
Separador para vestibulo
carteur pour vestibulum
Separatore per vestibulo



1 2

Sternberg
38-249-14-01
14 cm 5 4/8



1 2

Cawood-Minnesota
38-263-15-01
15,5 cm 6 1/8

Zungendrucker

Tongue Depressors

Abajalenguas

Abaisse-langue

Abassalingua

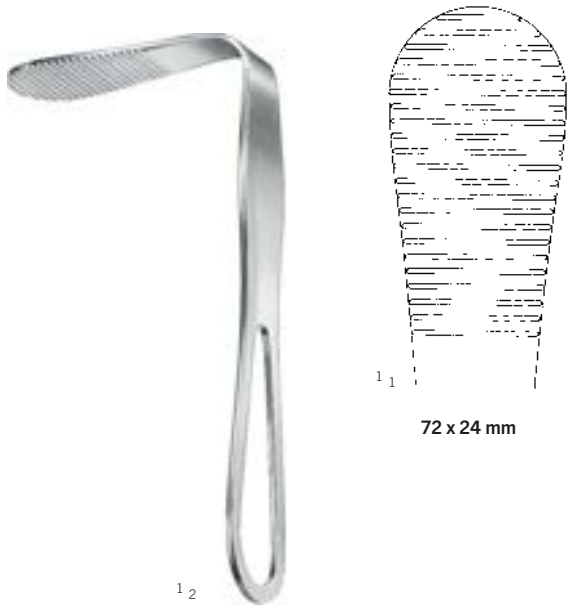

72 x 24 mm

Hartmann
38-271-15-07
15 cm 5⁷/₈



83 x 25 mm

Tobold
38-277-14-07
15 cm 5⁷/₈



38-297-01-01
14 cm 5⁴/₈
38 mm

38-297-02-01
15 cm 5⁷/₈
43 mm

Wieder
38-297-01-01 -
38-297-02-01

Weichteilhaken

Soft Tissue Retractors
Separadores para partes blandas
Crochets pour parties molles
Separatori per tessuti molli

Mund-, Kiefer- und Gesichtschirurgie

Oral Maxillo-facial Surgery
Cirugía oral y maxilofacial
Chirurgie buccale et maxillo-faciale
Chirurgia maxillo-facciale

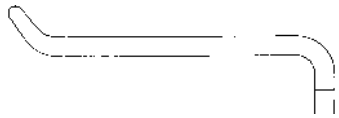

38-603-40-07

22,5 cm 8⁷₈

43 x 11 mm

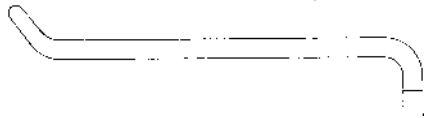

38-603-55-07

23 cm 9

57 x 11 mm

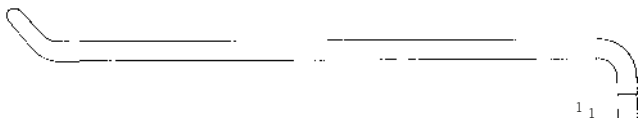

38-603-80-07

23 cm 9

80 x 16 mm



1₂

Obwegeser
38-603-40-07 -
38-603-80-07

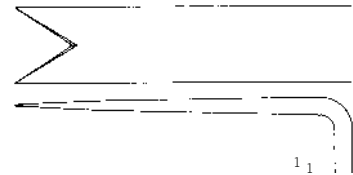

1₁

43 x 10 mm



1₂

Obwegeser
38-605-22-07

22 cm 8⁵₈

Spina nasalis-Haken
Nasal Spine Retractor
Separador para spina nasalis
carteur pour spina nasalis
Separatore per spina nasale

Ramushaken, Kinnhalter, Progenierinnen

Ramus Retractors, Chin Retractor, Channel Retractors

Separadores para el ramo, Gancho de mentón, Separadores mandibulares

carteurs pour ramus, Fixe-menton, carteurs mandibulaires

Separatore per ramo, Guancio per mento, Separatori mandibulari



Obwegeser
38-607-22-07
22 cm 8⁵/₈



Obwegeser
38-611-16-07
16,5 cm 6⁴/₈



38-613-08-07
16 cm 6²/₈
8 mm

38-613-10-07
16 cm 6²/₈
10 mm

Obwegeser
38-613-08-07 -
38-613-10-07

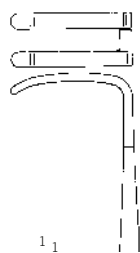

Koberg
38-616-01-07
15 x 7 mm

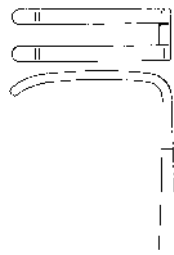

Koberg, mod.
38-616-02-07
20 x 7 mm

38-616-01-07 -
38-616-02-07
18 cm 7¹/₈

Progeniehaken

Progeny Retractor
Separadores para progenismo
Crochets de progenie
Separatori per progenismo

Mund-, Kiefer- und Gesichtschirurgie

Oral Maxillo-facial Surgery
Cirugía oral y maxilofacial
Chirurgie buccale et maxillo-faciale
Chirurgia maxillo-facciale

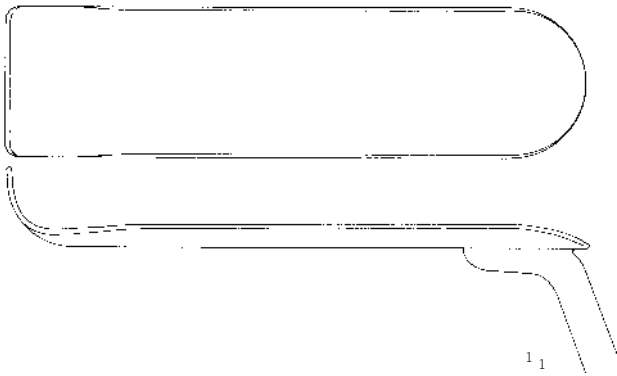

1 2

Schuchardt
38-614-10-07
18 cm 7 ¹/₈



1 2

Metz
38-614-20-07
19,5 cm 7 ⁵/₈

Progeniehaken

Progeny Retractor

Separadores para progenismo

Crochets de progenie

Separatori per progenismo

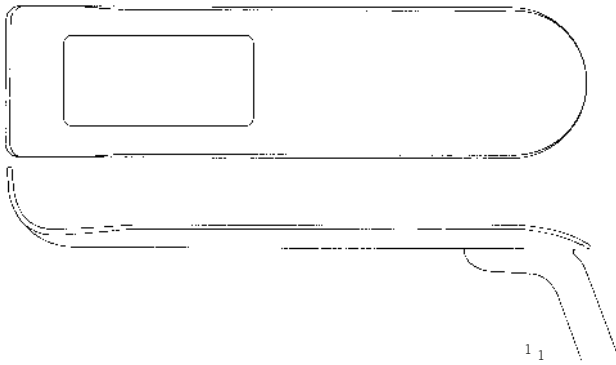

11



11



12

Schuchardt-Lauer
38-616-10-07

15 cm 5⁷/₈



12

Metz-Lauer
38-616-20-07

15 cm 5⁷/₈

Progeniehaken

Progeny Retractor
Separadores para progenismo
Crochets de progenie
Separatori per progenismo

Mund-, Kiefer- und Gesichtschirurgie

Oral Maxillo-facial Surgery
Cirugía oral y maxilofacial
Chirurgie buccale et maxillo-faciale
Chirurgia maxillo-facciale

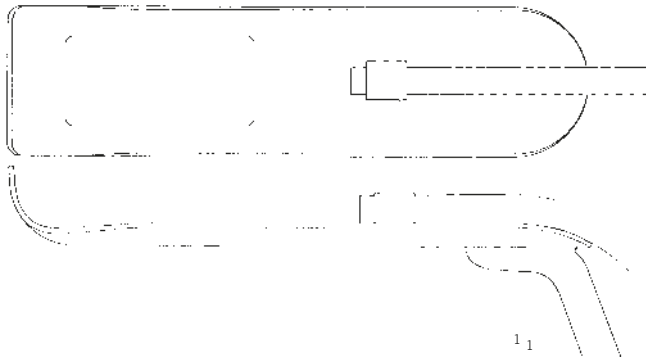

1 1



1 2

Schuchardt-Lauer
38-618-10-07

15 cm 5 7 8



1 2

Metz-Lauer
38-618-20-07

15 cm 5 7 8



Progeniehaken

Progeny Retractor

Separadores para progenismo

Crochets de progenie

Separatori per progenismo

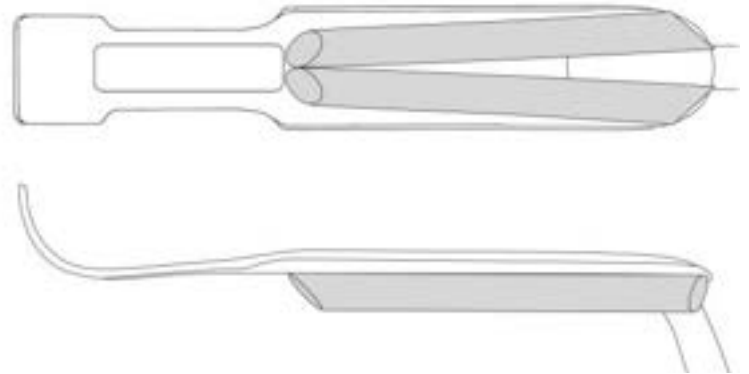
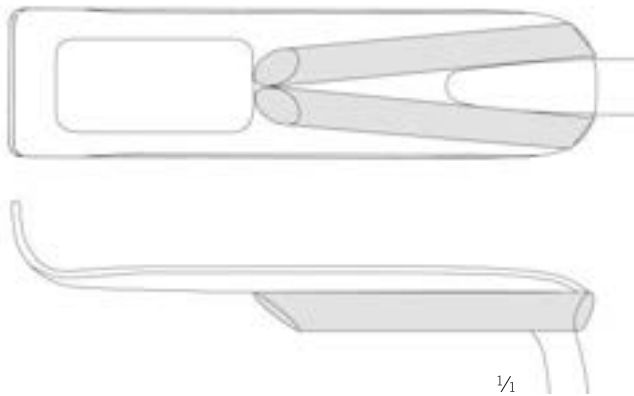

1/2

Schuchardt-Lauer
38-620-10-07
20 cm 7⁷/₈



1/2

Metz-Lauer
38-620-20-07
20 cm 7⁷/₈

Raspatorien

Periosteal levators
Periostótomos
Rugines-raspatoires
Periostotomi

Mund-, Kiefer- und Gesichtschirurgie

Oral Maxillo-facial Surgery
Cirugía oral y maxilofacial
Chirurgie buccale et maxillo-faciale
Chirurgia maxillo-facciale

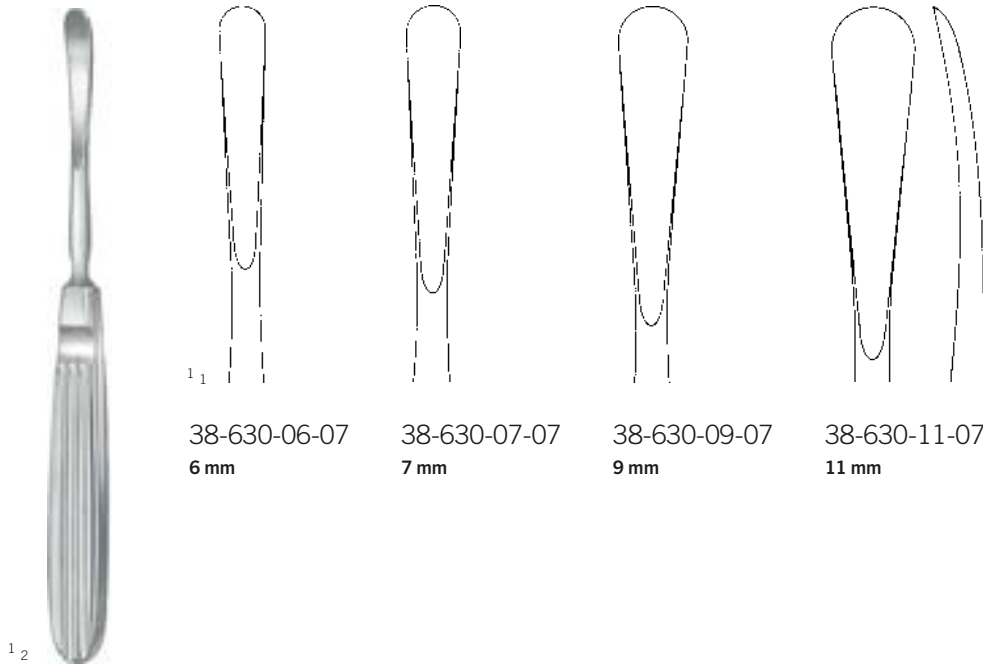

38-630-06-07
6 mm

38-630-07-07
7 mm

38-630-09-07
9 mm

38-630-11-07
11 mm

Obwegeser
38-630-06-07 - 38-630-11-07
17,5 cm 6 7/8



38-631-05-07
5 mm

38-631-07-07
7 mm

38-631-09-07
9 mm

Obwegeser
38-631-05-07 - 38-631-09-07
20 cm 7 7/8

Raspatorien

Periosteal levators
 Periostótomos
 Rugines-raspatoires
 Periostotomi



1₂

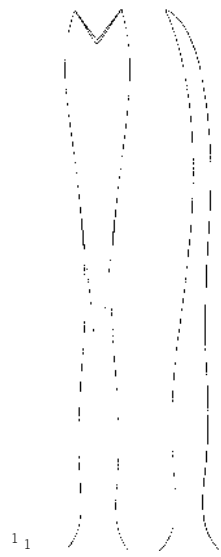

38-632-01-07



38-632-02-07

Obwegeser
 38-632-01-07 - 38-632-02-07
 17,5 cm 6⁷/₈



1₂



38-633-01-07

Periostelevatorium
 Periosteal levator
 Legra
 Rugine-raspatoire
 levatore per periosteo

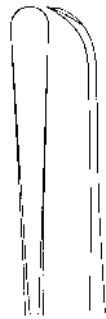

38-633-02-07

Periostelevatorium
 Periosteal levator
 Legra
 Rugine-raspatoire
 levatore per periosteo

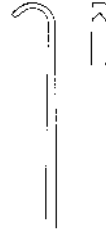
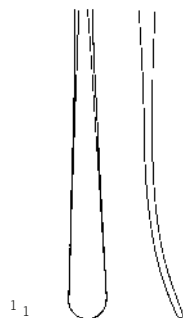

Fig. 11
 38-633-03-07

Gelenkpositionierer
 Condylar Repositioning Instrument
 Instrumento para reposicion condylar
 Repositionneur pour articul. mahoire
 Strumento di riposizionamento condilare



Fig. 12
 38-633-04-07



1₁

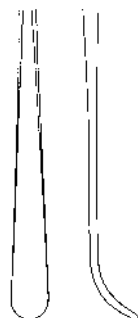

Krenkel
 38-633-01-07 - 38-633-04-07
 24,5 cm 9⁵/₈

Elevatorien, Drahtpositionierer, Drahtbogen

levators, Wire Pushers
levadores, mpujadores de alambres
lévateurs, Outil de positionnement
levatori, Posizionatori per filo

Mund-, Kiefer- und Gesichtschirurgie

Oral Maxillo-facial Surgery
Cirugía oral y maxilofacial
Chirurgie buccale et maxillo-faciale
Chirurgia maxillo-facciale



Obwegeser
38-640-21-07
20,5 cm 8¹/₈



Obwegeser
38-642-21-07
20,5 cm 8¹/₈

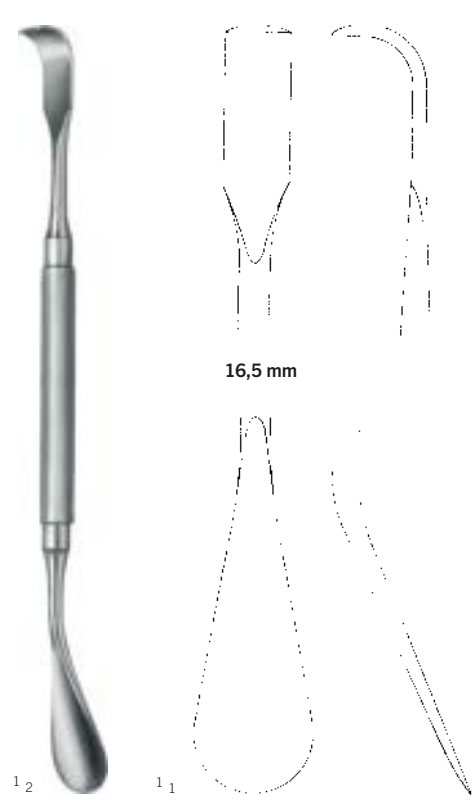

Donovan
38-694-20-07
19,5 cm 7⁵/₈
Orbitarand-Retractor
Orbital Hook, Orbital Rim Retractor
Gancho orbital, Separador reb. Orbital
Crochet orbital, carteur orbital
Divericatore orbitale



rich
38-690-00-07
Gesamtlänge
Overall length
Longitud total
Longueur totale
Lunghezza complessiva
1 m

Knochenquetsche

Bone crusher

Aplastador óseo

Presse d'os

Strumento per schiacciamento ossa

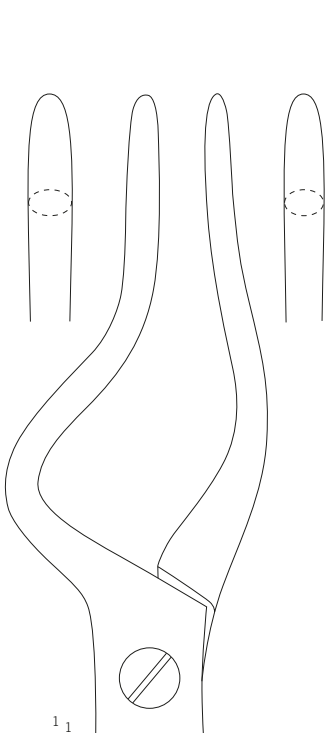

38-700-01-07 **L**
38-701-01-07 **R**
21,5 cm 8⁴/₈

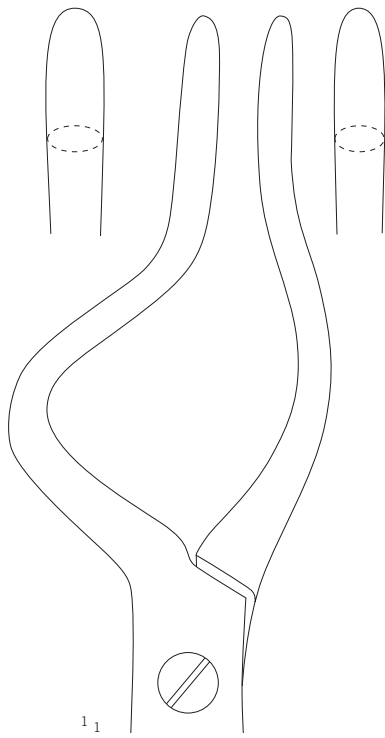

38-700-02-07 **L**
38-701-02-07 **R**
24 cm 9⁴/₈

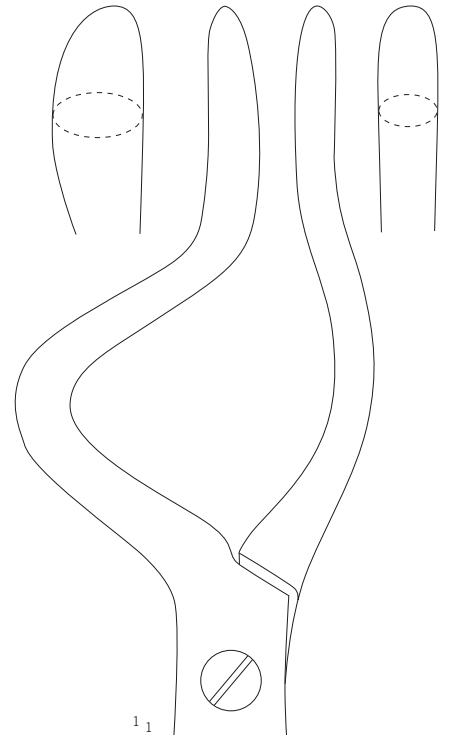

38-700-03-07 **L**
38-701-03-07 **R**
24,5 cm 9⁵/₈



Rowe
L
links
left
izquierdo
gauche
sinistra



Rowe
R
rechts
right
derecho
droit
destra

Zygoma-Elevatorien

Zygoma levators
 levadores cigomáticos
 levateurs zygomatiques
 levatori per zigomo

Mund-, Kiefer- und Gesichtschirurgie

Oral Maxillo-facial Surgery
 Cirugía oral y maxilofacial
 Chirurgie buccale et maxillo-faciale
 Chirurgia maxillo-facciale



1₂

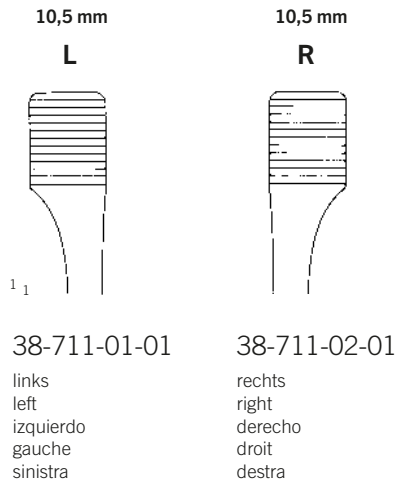

Tessier

38-711-01-01 - 38-711-02-01

Mobilisierhaken
 Maxillary Mobilizer
 Gancho para movilización
 Mobilisateur
 Gancio per mobilizzare



1₂

Dingmann-Wilk
 38-715-19-07
 20 cm 7⁷/₈

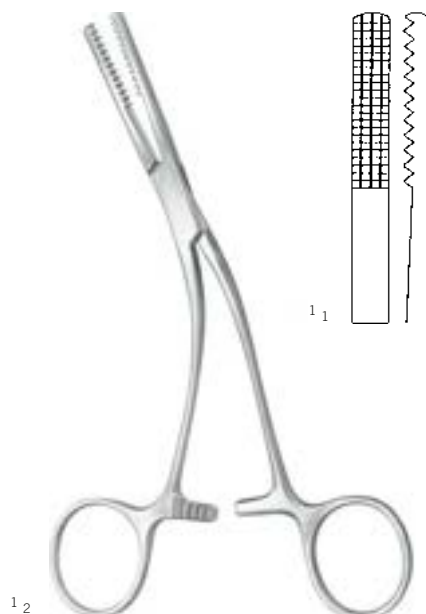

1₂

Salyer
 38-723-16-07
 16,5 cm 6⁴/₈

Osteotome

Osteotomes

Osteótomos

Ostéotomes

Osteotomi

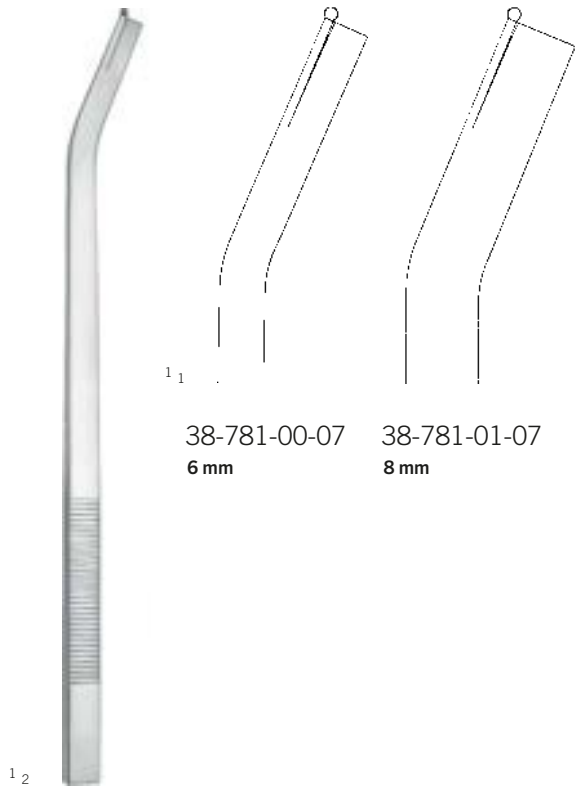

38-781-00-07
6 mm

38-781-01-07
8 mm

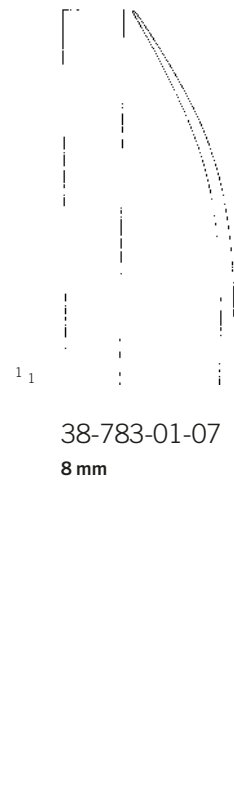

38-783-01-07
8 mm

Bauer
38-781-00-07 -
38-781-01-07
20,5 cm 8¹/₈

pkker-Bauer
38-783-01-07
17,5 cm 6⁷/₈

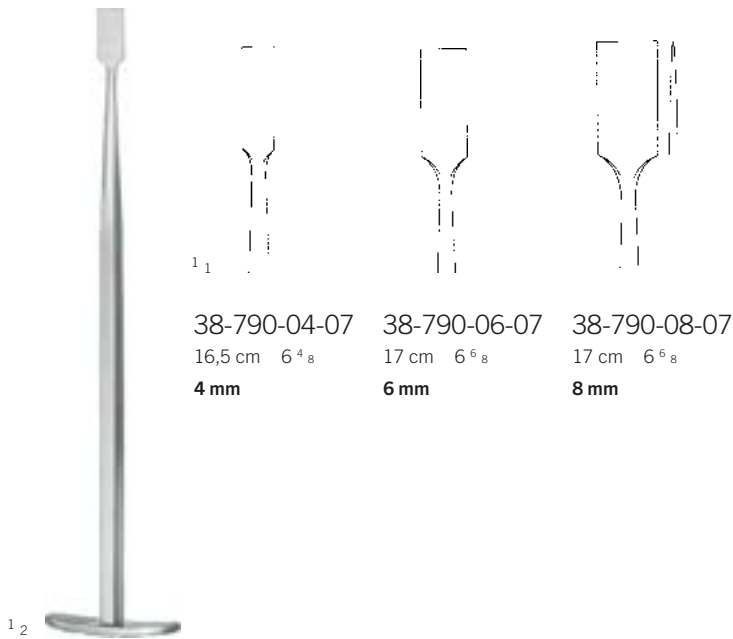

38-790-04-07
16,5 cm 6⁴/₈
4 mm

38-790-06-07
17 cm 6⁶/₈
6 mm

38-790-08-07
17 cm 6⁶/₈
8 mm

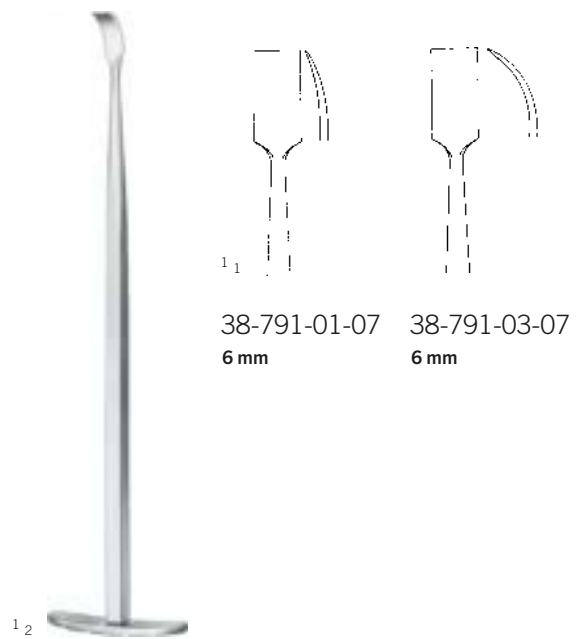

38-791-01-07
6 mm

38-791-03-07
6 mm

Dunn-Dautrey
38-790-04-07 -
38-790-08-07

Dunn-Dautrey
38-791-01-07 -
38-791-03-07
17 cm 6⁶/₈

Osteotome

Osteotomes
Osteótomos
Ostéotomes
Osteotomi

Mund-, Kiefer- und Gesichtschirurgie

Oral Maxillo-facial Surgery
Cirugía oral y maxilofacial
Chirurgie buccale et maxillo-faciale
Chirurgia maxillo-facciale

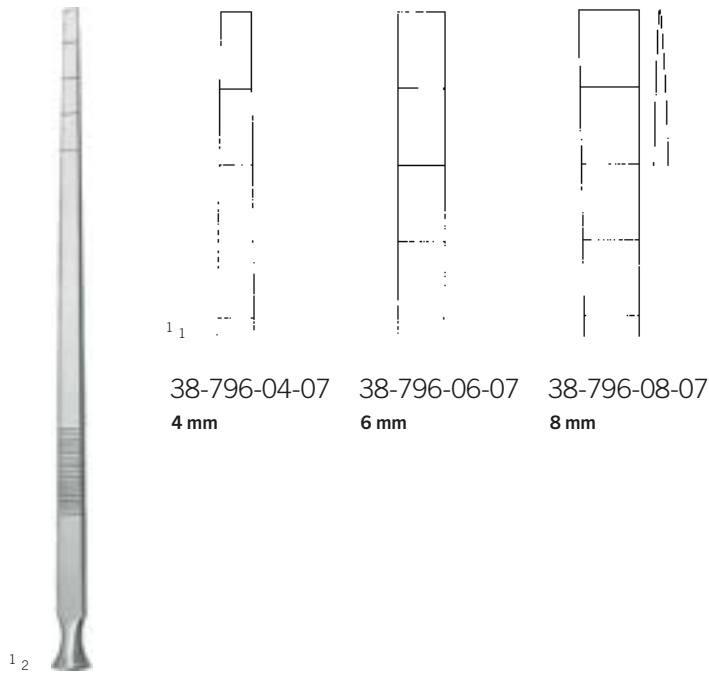

38-796-04-07
4 mm

38-796-06-07
6 mm

38-796-08-07
8 mm

pker
38-796-04-07 -
38-796-08-07
18 cm 7¹/₈

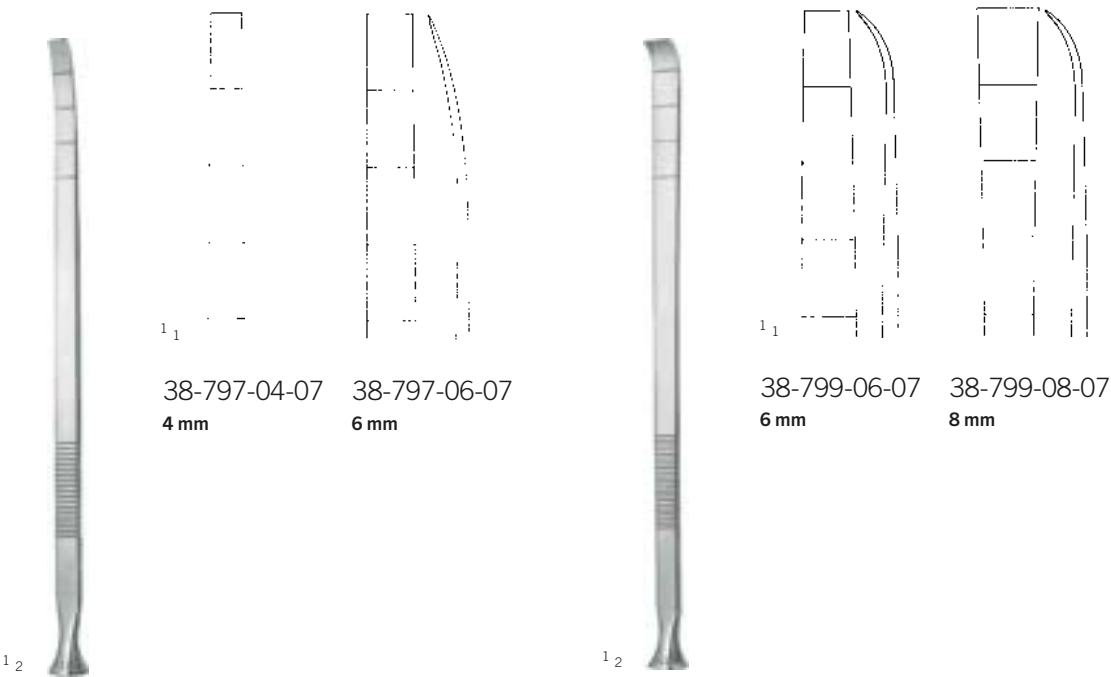

38-797-04-07
4 mm

38-797-06-07
6 mm

38-799-06-07
6 mm

38-799-08-07
8 mm

pker
38-797-04-07 -
38-797-06-07
18 cm 7¹/₈

pker
38-799-06-07 -
38-799-08-07
18 cm 7¹/₈

Ramushaken

Ramus Retractors
Separadores para el ramo
carteurs pour ramus
Divaricatori per il ramo

Unterkieferkörperhaken, Vorderrandstripper

Mandibular Body Retractor, Anterior Border Stripper
Separador para el cuerpo mandibular, Separador para el borde anterior
carteur pour corps mandibulaire, carteur pour le bord antérieur
Separatore per il corpo mandibulare, Separatore per il bordo anteriore

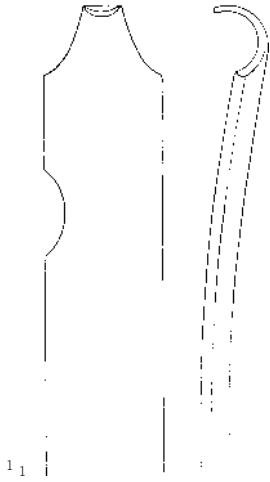

38-831-01-07

links
left
izquierdo
gauche
sinistra



38-831-02-07

rechts
right
derecho
droit
destra

Hargis
38-831-01-07 -
38-831-02-07
19,5 cm 7⁵/₈

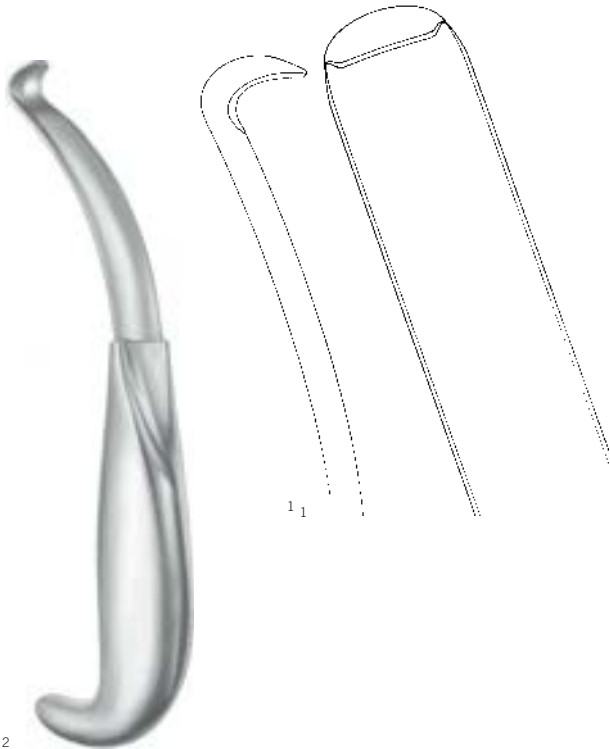

Hargis
38-833-18-07
17,5 cm 6⁷/₈



Hargis
38-835-19-07
18,5 cm 7²/₈

Raspatorien

Periosteal levators
Legras
Rugine-raspatoires
levatori per periosteo

Mund-, Kiefer- und Gesichtschirurgie

Oral Maxillo-facial Surgery
Cirugía oral y maxilofacial
Chirurgie buccale et maxillo-faciale
Chirurgia maxillo-facciale



¹₂

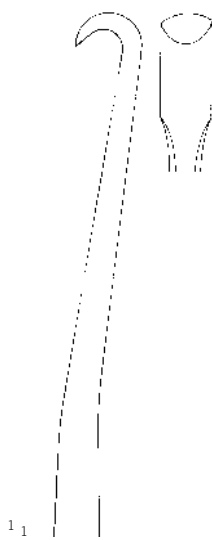

¹₁

38-837-01-07

23,5 cm 9²_a

6,5 mm

rechts
right
derecho
droit
destra

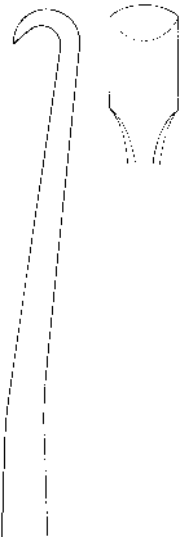

38-837-02-07

23 cm 9

9 mm

rechts
right
derecho
droit
destra

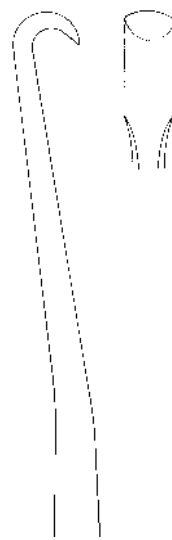

38-837-03-07

23,5 cm 9²_a

6,5 mm

links
left
izquierdo
gauche
sinistra

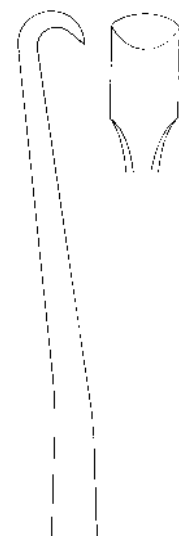

38-837-04-07

23 cm 9

9 mm

links
left
izquierdo
gauche
sinistra

Hargis
38-837-01-07 -
38-837-04-07

Piriformis-Haken, Pterygoideus-Osteotom,

Periform Rim Retractor, Pterygoid Osteotome,

Gancho piriforme, Osteótomo pterigoideo,

Crochet pour la fosse piriforme, Ostéotome ptérygoïde,

Divaricatore per piriforme, Osteotomo per pterigoideo,

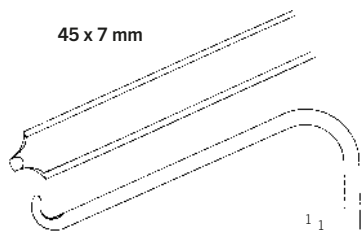

Hargis
38-839-18-07
18,5 cm 7²/₈

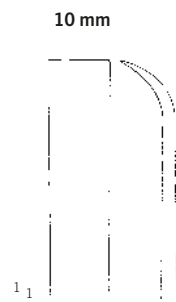

Hargis
38-841-22-07
22 cm 8⁵/₈

Sagittalspreizer, Spreizzange

Sagittal Split Separators, Ramus Separator
Separadores sagitales, Pinza para separar la rama
carteurs sagittaux, Pince pour séparer ramus
Separatori sagittali, Pinza per separare il ramo

Mund-, Kiefer- und Gesichtschirurgie

Oral Maxillo-facial Surgery
Cirugía oral y maxilofacial
Chirurgie buccale et maxillo-faciale
Chirurgia maxillo-facciale

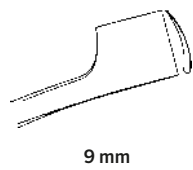
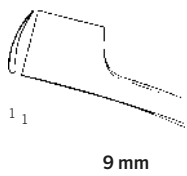

Smith
38-845-01-07
18,5 cm 7²₈
rechts
right
destra
derecho
droit

Smith
38-845-02-07
18,5 cm 7²₈
links
left
sinistra
izquierdo
gauche

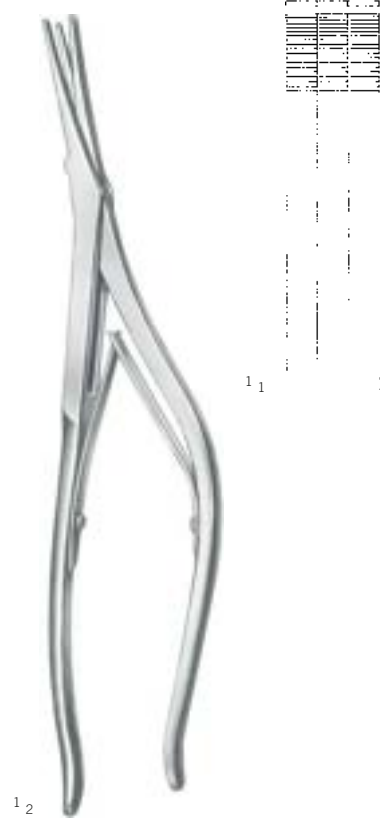

Smith
38-846-20-07
23,5 cm 9²₈

Mylohyoideusklemmen

Mylohyoid Muscle Clamps

Pinzas para el músculo milohioideo

Clamp mylohyoidal

Pinze per muscolo miloideo

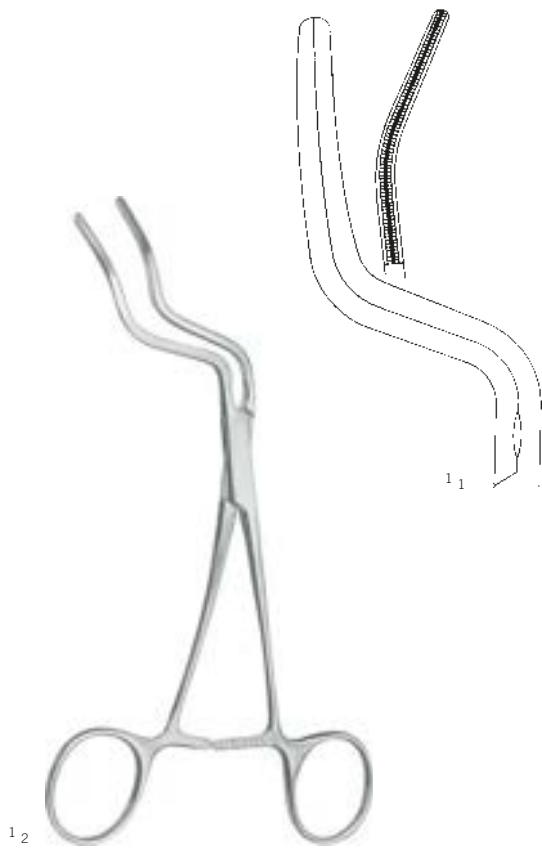

Terry
38-850-01-07
17 cm 6⁶/₈
links
left
izquierdo
gauche
sinistra

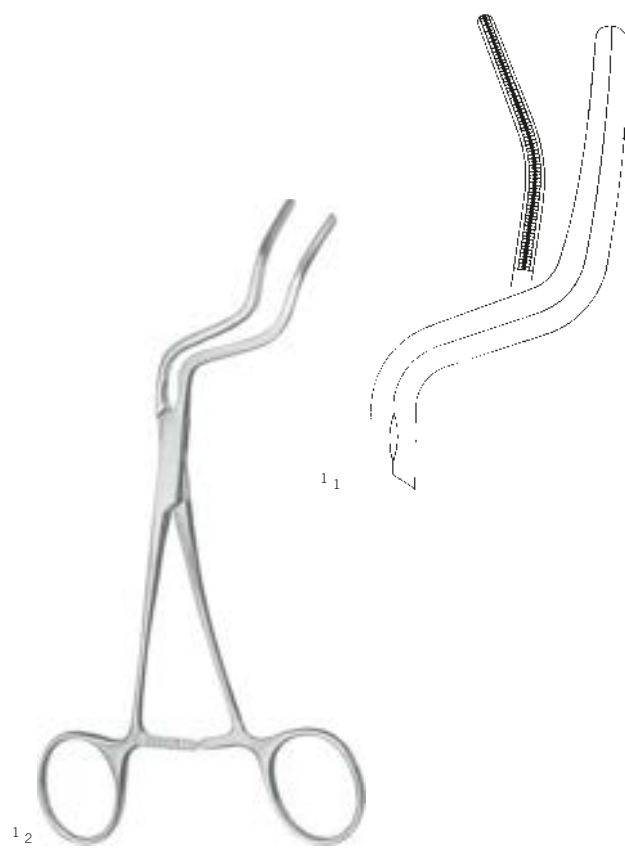

Terry
38-850-02-07
17 cm 6⁶/₈
rechts
right
derecho
droit
destra



Terry
38-851-16-07

16,5 cm 6⁴₈

Unterkieferhaken
Mandibular Retractors
Gancho mandibular
Crochet mandibulaire
Divaricatore per mandibula



Terry
38-853-24-07

24 cm 9⁴₈

Ramusschieber
Ramus Pusher
Corredera de rama
Manipulateur pour ramus
DPosizionatore per ramo



Terry
38-856-19-07

19 cm 7⁴₈

Septumosteotom
Septal Osteotome
Osteótomo nasal
Ostéotome nasale
Osteotomo nasale

Haken, Elevatorien

Hooks, levators

Ganchos, levadores

carteurs, levateurs

Divaricatori, levatori



1_1



1_1

Turvey
38-870-17-07

17 cm 6⁵/₈

Unterkieferhaken
Mandibular Retractors
Gancho mandibular
Crochet mandibulaire
Divaricatore per mandibula

1_2

Steinh user
38-877-00-07

27 cm 10⁵/₈

levatorium, extra lang
levator, extra long
levador de rama, muy largo
levateur, tr s long
levatore, molto lungo

Ramusklemmen

Ramus Clamps
Pinzas de rama
Clamps pour ramus
Pinze per ramo

Mund-, Kiefer- und Gesichtschirurgie

Oral Maxillo-facial Surgery
Cirugía oral y maxilofacial
Chirurgie buccale et maxillo-faciale
Chirurgia maxillo-facciale

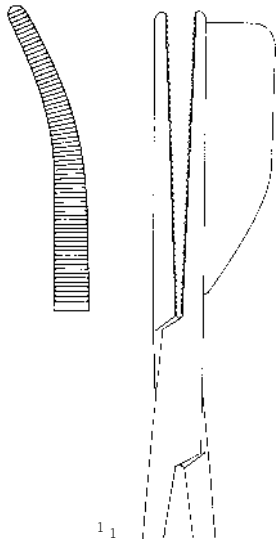

1₁

38-878-01-07

rechts
right
derecho
droit
destra

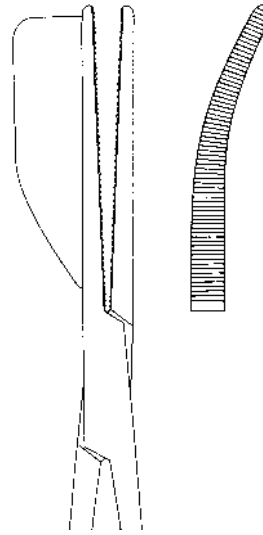

38-878-02-07

links
left
izquierdo
gauche
sinistra



1₂

Steinh user
38-878-01-07
16 cm 6²/₈



1₂

Steinh user
38-878-02-07
16 cm 6²/₈

Ramusosteotome, Meißel

Ramus Osteotomes, Chisels

Osteótomos de rama, Cinceles

Ostéotome pour ramus, Ciseaux-burins

Osteotomi per ramo, Scalpelli

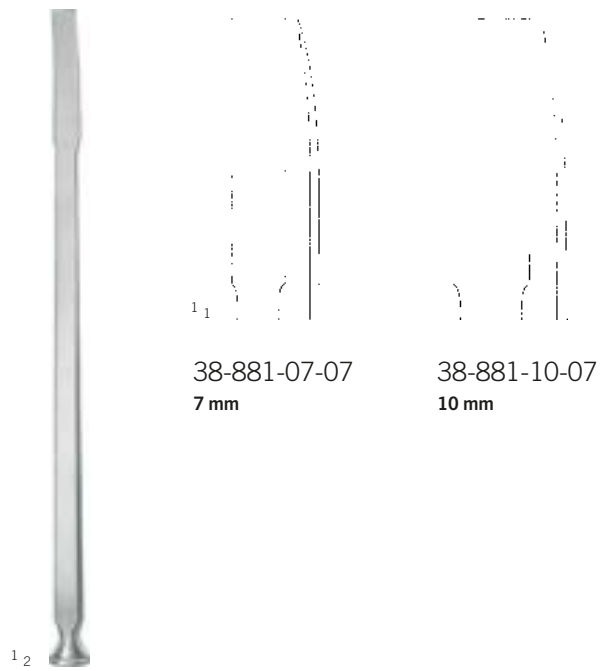

Steinh user
38-881-07-07 - 38-881-10-07

17 cm 6⁶ s

flexibel
flexible
flexible
flexible
flessibile

Ramusosteotome, Meißel

Ramus Osteotomes, Chisels
Osteótomos de rama, Cinceles
Ostéotome pour ramus, Ciseaux-burins
Osteotomi per ramo, Scalpelli

Mund-, Kiefer- und Gesichtschirurgie

Oral Maxillo-facial Surgery
Cirugía oral y maxilofacial
Chirurgie buccale et maxillo-faciale
Chirurgia maxillo-facciale



1₂



1₁

38-883-07-07
7 mm



38-883-11-07
11 mm

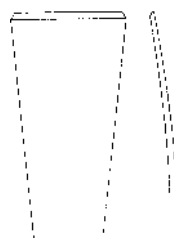

38-883-15-07
15 mm



1₂

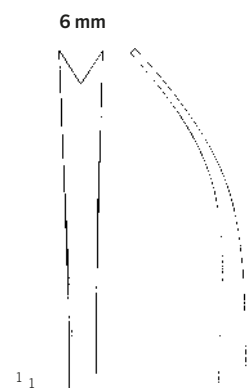

1₁

6 mm

Steinh user
38-883-07-07 -
38-883-15-07
19 cm 7¹/₈

Steinh user
38-885-18-07
18 cm 7¹/₈
Repositionsinstrument
Reposition Instrument
Instrumento de reposición
Pince de réposition
Strumento per riduzione

Raspatorien, Osteotome

Raspatories, Osteotomes

Legras, Osteótomos

Rugine-raspatoires, Ostéotomes

levatori per periosteo, Osteotomi

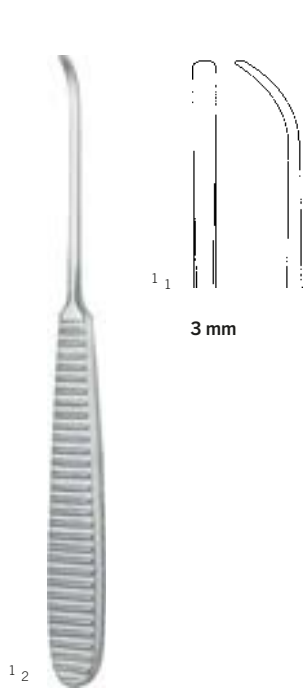

Steinh user
38-893-16-07
16,5 cm 6⁴₈

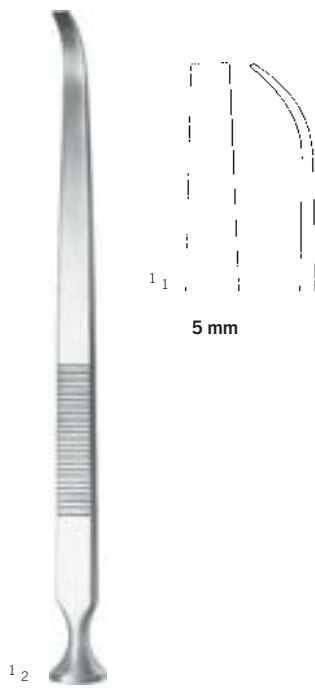

Steinh user
38-895-05-07
18 cm 7¹₈

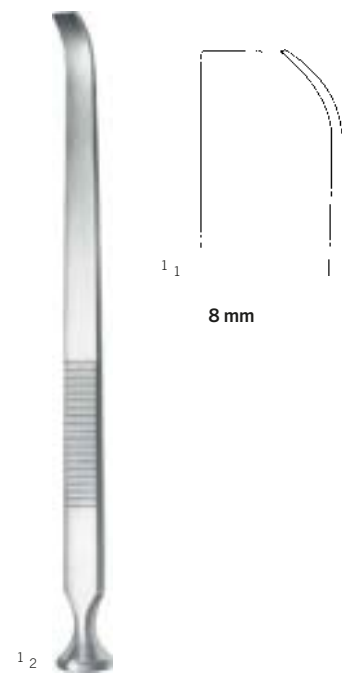

Steinh user
38-895-08-07
18 cm 7¹₈

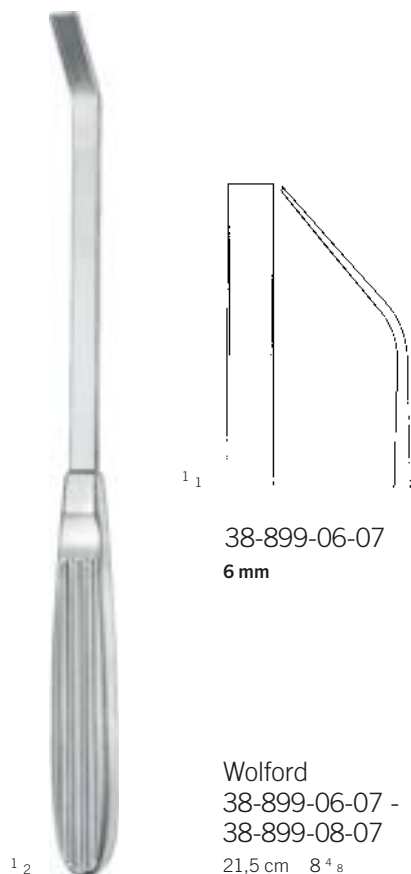

Woford
38-899-06-07 -
38-899-08-07
21,5 cm 8⁴₈

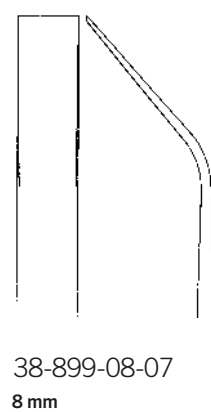

Zwickzangen, Bügelbiegezangen

end and side nippers, bar bending pliers
Alicates cortantes y alicates para doblar alambres
Pinces, pinces courber les branches
Tenaglie, tenaglie per la piegatura di staffe

Mund-, Kiefer- und Gesichtschirurgie

Oral Maxillo-facial Surgery
Cirugía oral y maxilofacial
Chirurgie buccale et maxillo-faciale
Chirurgia maxillo-facciale



Mershon
46-528-01-07

Bandtreiber
Band pusher
Ajustador de bandas
Ajusteur de bande
Dispositivo di azionamento
del nastro



Schwarz
47-606-13-07
13 cm 5 1/8



Schwarz
47-608-13-07
13 cm 5 1/8

Weichteilhaken

Soft Tissue Retractors

Separadores para partes blandas

carteurs pour parties molles

Divaricatori per tessuti molli

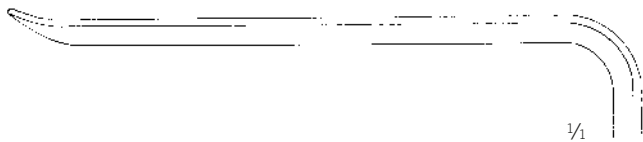

1/2

Obwegeser
48-101-16-07 -
48-101-80-07

aufw rts gebogen
bent upwards
angulado hacia arriba
coudé en haut
angolato in alto

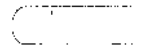

48-101-16-07

21,5 cm 8³/₈

16 x 5 mm



48-101-25-07

21 cm 8²/₈

25 x 7 mm



48-101-35-07

23 cm 8

35 x 10 mm



48-101-42-07

23 cm 8

42 x 10 mm

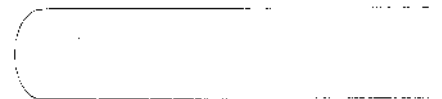

48-101-55-07

23,5 cm 9²/₈

57 x 12,5 mm



48-101-70-07

23,8 cm 9³/₈

72 x 15 mm



1/4

48-101-80-07

24 cm 9⁴/₈

86 x 17 mm

Weichteilhaken

Soft Tissue Retractors
Separadores para partes blandas
carteurs pour parties molles
Divaricatori per tessuti molli

Mund-, Kiefer- und Gesichtschirurgie

Oral Maxillo-facial Surgery
Cirugía oral y maxilofacial
Chirurgie buccale et maxillo-faciale
Chirurgia maxillo-facciale



1/2

Obwegeser
48-103-16-07 -
48-103-80-07

abwärts gebogen
bent downwards
angulado hacia abajo
coudé en bas
angolato in basso

1/4

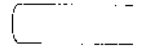

48-103-16-07

21 cm 8² s

16 x 5 mm



48-103-25-07

21 cm 8² s

25 x 7 mm



48-103-35-07

23 cm 8

35 x 10 mm



48-103-42-07

23 cm 8

42 x 10 mm



48-103-55-07

23,5 cm 9² s

55 x 12 mm



48-103-70-07

23,5 cm 9² s

72 x 15 mm



48-103-80-07

23,5 cm 9² s

86 x 17 mm

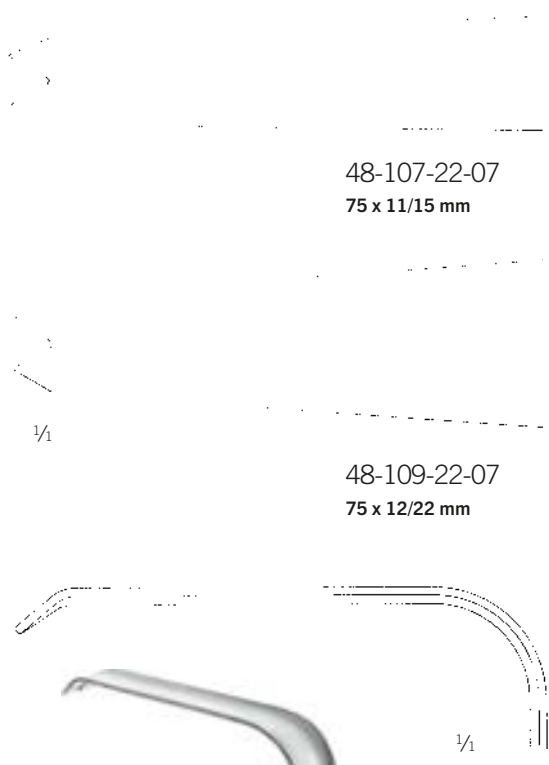

48-107-22-07
 75 x 11/15 mm

48-109-22-07
 75 x 12/22 mm

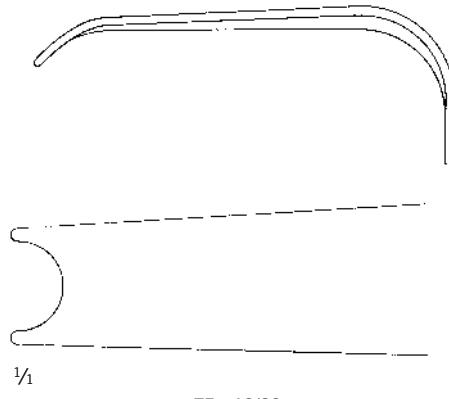

75 x 12/22 mm

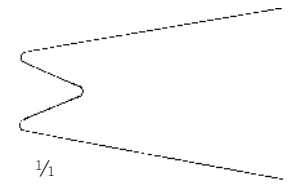

45 x 10/23 mm



1/2



1/2



1/2

Obwegeser
 48-107-22-07 - 48-109-22-07
 24 cm 9⁴/₈
 Ramushaken
 Ramus Retractors
 Separadores para el ramo
 carteurs pour ramus
 Divaricatori per il ramo

Obwegeser
 48-111-22-07
 24 cm 9⁴/₈
 Weisheitszahn-Haken
 Third Molar Retractor
 Separador para muela del juicio
 carteur pour dent de sagesse
 Separatore per il dente del giudizio

Obwegeser
 48-113-22-07
 24 cm 9⁴/₈
 Spina nasalis-Haken
 Nasal Spine Retractor
 Separador para espina nasal
 carteur pour spina nasalis
 Separatore per spina nasale

Progenierinnen

Channel Retractors
Separadores mandibulares
carteurs mandibulaires
Divaricatori mandibulari

Mund-, Kiefer- und Gesichtschirurgie

Oral Maxillo-facial Surgery
Cirugía oral y maxilofacial
Chirurgie buccale et maxillo-faciale
Chirurgia maxillo-facciale



48-121-08-07

16 cm 6²s

9 mm



48-121-10-07

16,5 cm 6⁴s

10 mm



1/2

Obwegeser
48-121-08-07 -
48-121-10-07

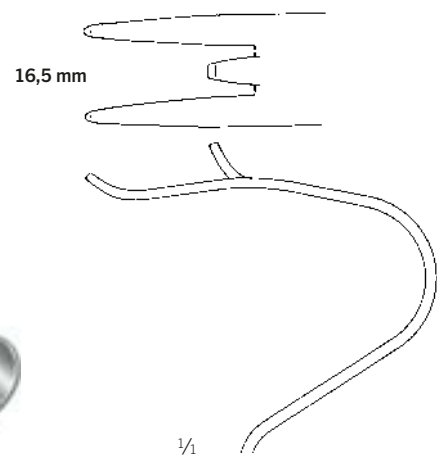

1/2

Obwegeser
48-125-15-07
16 cm 6²s
Kinnhalter
Chin Holder
Separador para mentón
carteurs pour menton
Separatore per mento

Raspatorien

Periosteal levators
 Periostótomos
 Rugines-raspatoires
 Periostotomi



1/2

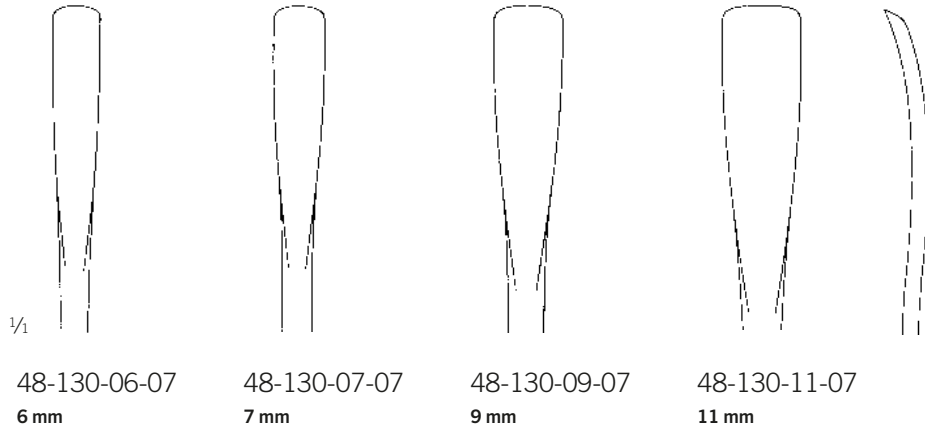

1/1

48-130-06-07
 6 mm

48-130-07-07
 7 mm

48-130-09-07
 9 mm

48-130-11-07
 11 mm

Obwegeser
 48-130-06-07 - 48-130-11-07

18 cm 7 1/8

winkelig angeschliffen
 angled cutting
 biselado angular
 tranchant angulé
 affilatura angolata



1/2



1/1

48-132-06-07
 6 mm

48-132-07-07
 7 mm

48-132-09-07
 9 mm

48-132-11-07
 11 mm

Obwegeser
 48-132-06-07 - 48-132-11-07

18 cm 7 1/8

flach angeschliffen
 flat cutting
 biselado plano
 tranchant plat
 affilatura plana

Unterkieferrand-Raspatorien, Schwalbenschwanz-Raspatorien

Mandibular Inferior Border Raspatories, Swallowtail Raspatories

Legras para el borde mandibular, Legras en forma de cola de milano

Rugine-raspatoires pour le bord mandibulaire, Rugine-raspatoires sous forme de queue d'aronde

Staccaperiostio per bordo mandibulare, Staccaperiostio a coda di rondine

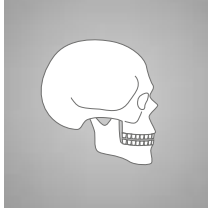

Obwegeser
48-135-21-07
21 cm 8²/₈



Obwegeser
48-137-21-07
21 cm 8²/₈



Obwegeser
48-140-01-07
18 cm 7¹/₈
nach links gewinkelt
angled to left
angulado hacia la izquierda
coudé gauche
angolato a sinistra

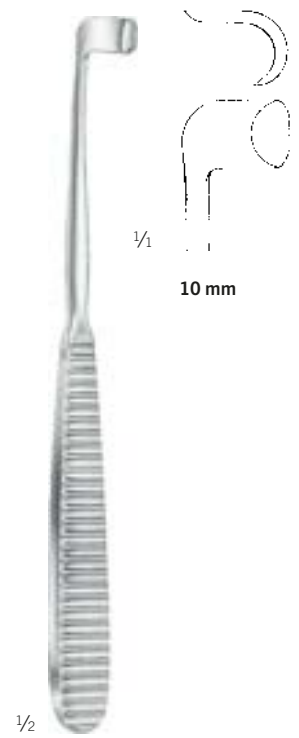

Obwegeser
48-140-02-07
18 cm 7¹/₈
nach rechts gewinkelt
angled to right
angulado hacia la derecha
coudé droite
angolato a destra

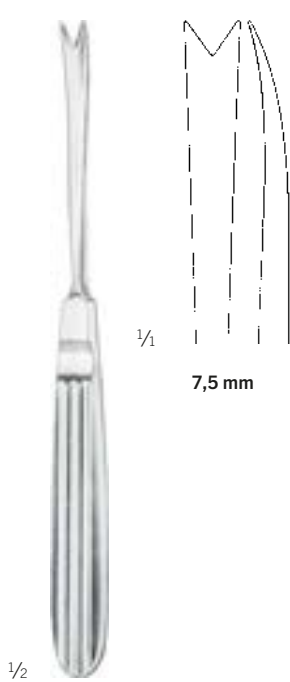

Obwegeser
48-150-01-07
17,5 cm 6⁷/₈

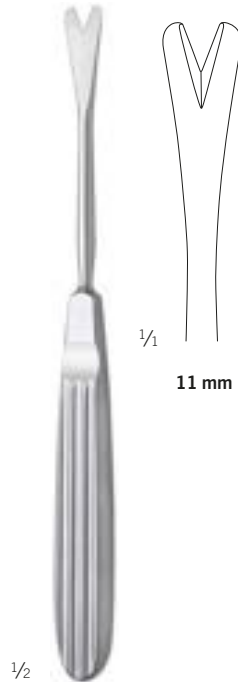

Obwegeser
48-150-02-07
17,5 cm 6⁷/₈

Ramusraspatorien, Septumosteotome

Ramus Periosteal elevators, Septonasal Osteotomes

Legras para el ramo, Osteótomos para el tabique nasal

Rugine-raspatoires pour ramus, Ostéotomes pour cloison nasale

levatori periostali per ramo, Osteotomo per setto nasale



1/4

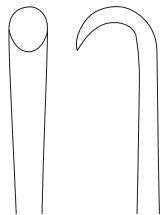

48-152-05-07
5 mm

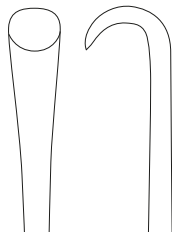

48-152-07-07
7 mm

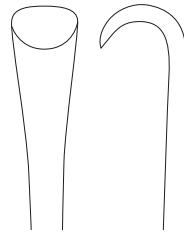

48-152-09-07
9 mm

1/2

Obwegeser

48-152-05-07 - 48-152-09-07

21 cm 8⁴/₈

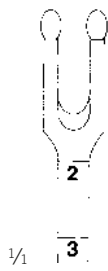

48-156-04-07
4 mm

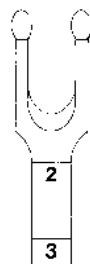

48-156-06-07
6 mm

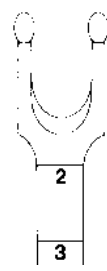

48-156-08-07
8 mm

1/4

1/2

Obwegeser

48-156-04-07 - 48-156-08-07

19 cm 7⁴/₈

graduiert
graduated
graduado
graduado
graduato

Keilosteotome

Wedge Osteotomes
Osteótomos de cuña
Ostéotome cunéiforme
Osteotomo a forma di cune

Mund-, Kiefer- und Gesichtschirurgie

Oral Maxillo-facial Surgery
Cirugía oral y maxilofacial
Chirurgie buccale et maxillo-faciale
Chirurgia maxillo-facciale



$\frac{1}{2}$

Obwegeser
48-161-08-04 -
48-161-16-04
22,5 cm 8⁷/₈



$\frac{1}{4}$

48-161-08-04
8 mm



48-161-12-04
12 mm

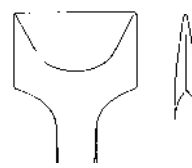

48-161-16-04
16 mm

Fragment-Adaptierungsklemmen

Fragment Adapting Forceps

Pinzas adaptadoras para fragmentos

Clamps pour adaptation de fragments osseux

Pinze per avvicinare frammenti

Atrauma

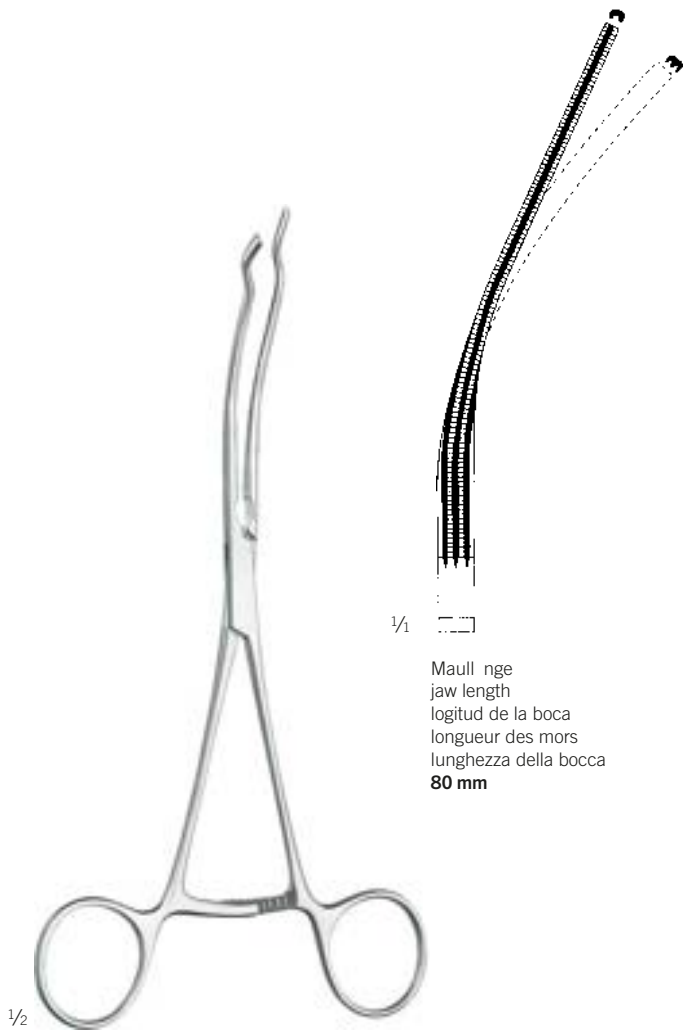

Maul nge
jaw length
logitud de la boca
longueur des mors
lunghezza della bocca
80 mm

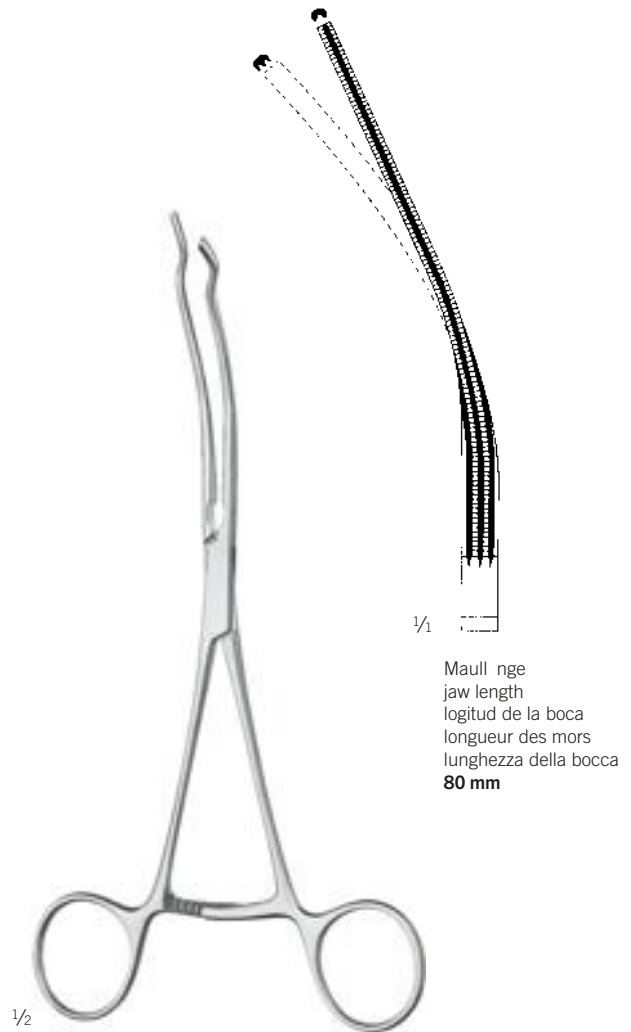

Maul nge
jaw length
logitud de la boca
longueur des mors
lunghezza della bocca
80 mm

Obwegeser
48-163-01-07

21 cm 8² s

links
left
izquierdo
gauche
sinistra

Obwegeser
48-163-02-07

21 cm 8² s

rechts
right
derecho
droit
destra

Knochenspreizer

Bone-spreader
Separador de huesos
Pince écarter
Pinza per allargare

Mund-, Kiefer- und Gesichtschirurgie

Oral Maxillo-facial Surgery
Cirugía oral y maxilofacial
Chirurgie buccale et maxillo-faciale
Chirurgia maxillo-facciale

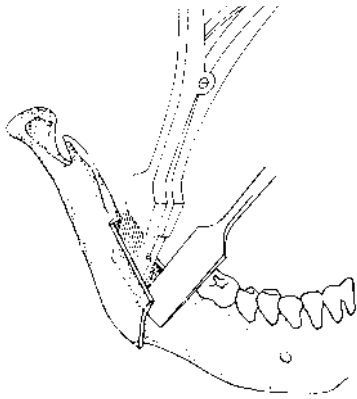

1/2

Obwegeser
48-164-15-07 -
48-164-20-07
22 cm 8⁵/₈

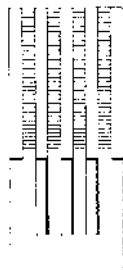

1/4

48-164-15-07
15 mm

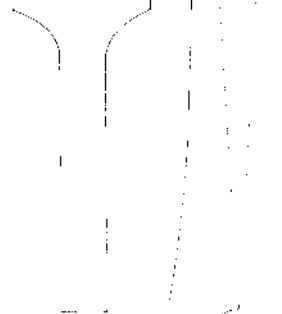
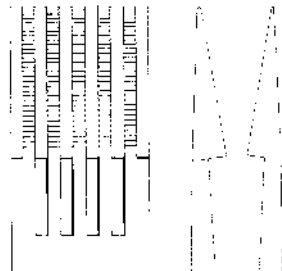

48-164-20-07
20 mm

Blattosteotome

Blade Osteotomes
Osteótomos de hoja
Ostéotome en lame
Osteotomo



48-165-08-04
8 mm



48-165-12-04
12 mm

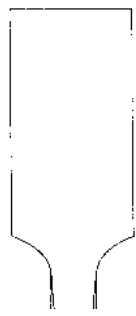

48-165-16-04
16 mm

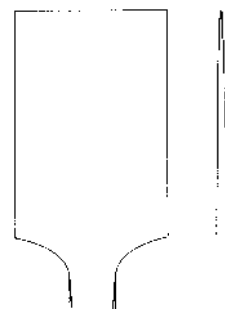

48-165-20-04
20 mm

1/2

Obwegeser
48-165-08-04 -
48-165-20-04
22,5 cm 8 7 8

Tuber maxillae-Osteotome, Osteotome

Osteotomes for Maxillary Tuber, Osteotomes
Osteótomos para tubérculo maxilar, Osteótomos
Ostéotome pour tuber-maxillae, Ostéotome
Osteotomo per tuberosit mascellari, Osteotomo

Mund-, Kiefer- und Gesichtschirurgie

Oral Maxillo-facial Surgery
Cirugía oral y maxilofacial
Chirurgie buccale et maxillo-faciale
Chirurgia maxillo-facciale

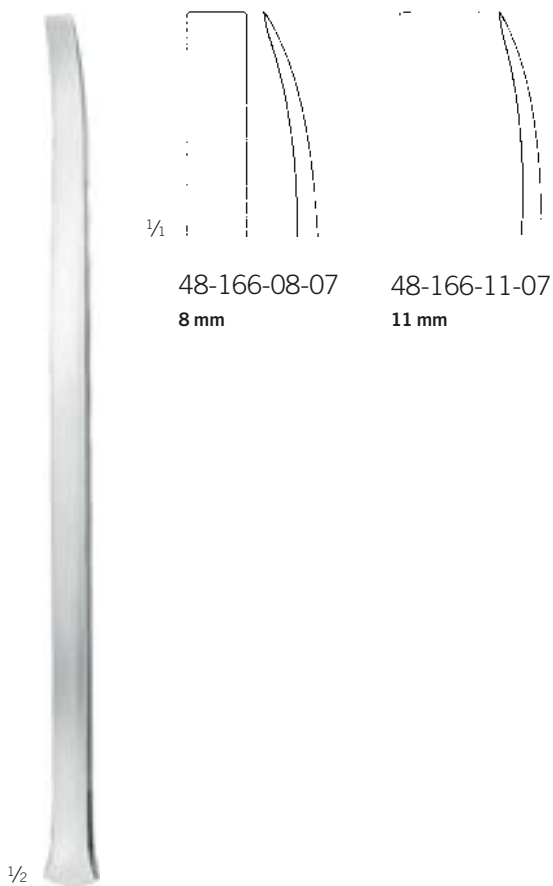

48-166-08-07
8 mm

48-166-11-07
11 mm

Obwegeser
48-166-08-07 -
48-166-11-07
23 cm 9

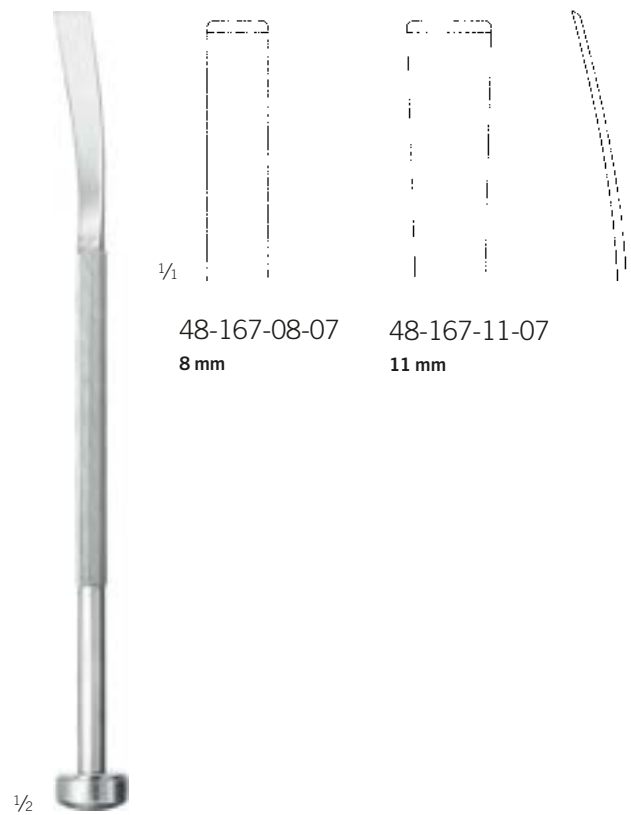

48-167-08-07
8 mm

48-167-11-07
11 mm

Obwegeser
48-167-08-07 -
48-167-11-07
21 cm 8 2 8
elastische Klinge
elastic blade
hoja el stica
lame élastique
lama elastica

Osteotome

Osteotomes

Osteótomos

Ostéotomes

Osteotomo

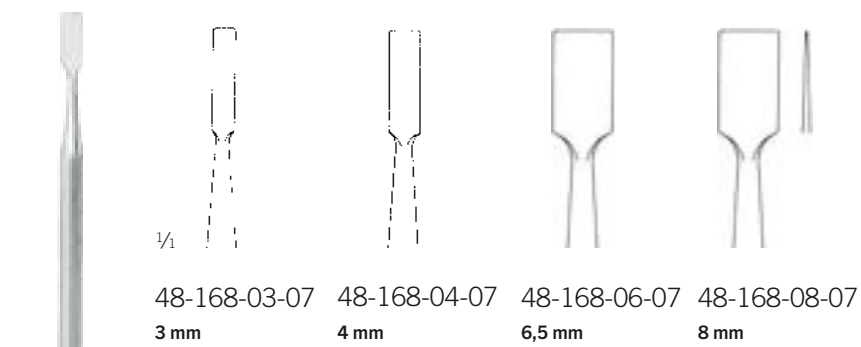

1/2

Obwegeser
48-168-03-07 -
48-168-08-07

15,5 cm 6¹/₈

für Kinnosteotomie
for midline flap
para osteotomía mentoniana
pour génioplastie
per osteotomia del mento

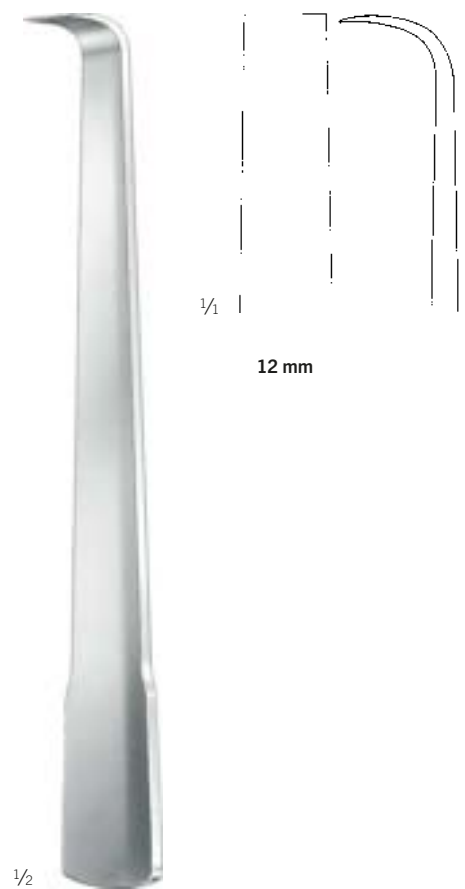

Obwegeser
48-170-23-07

23 cm 9

Maxilla-Mobilisator
Maxillary Mobilizer
Mobilizador maxilar
Mobilisateur pour maxillaire
Mobilizzatore per mascella

Drahtwirbelzangen, Knochenformzangen

Wire Twisting Forceps, Bone Contouring Forceps
 Pinzas para torcer alambre, Pinzas para formar huesos
 Pincers torsader le fil, Pincers pour former os
 Pinze per ritorcere fili, Pinze per afferrare ossa

Mund-, Kiefer- und Gesichtschirurgie

Oral Maxillo-facial Surgery
 Cirugía oral y maxilofacial
 Chirurgie buccale et maxillo-faciale
 Chirurgia maxillo-facciale



TC GOLD



1/4

48-196-14-07

1/2

Obwegeser
 48-196-14-07
 14 cm 5⁴ s

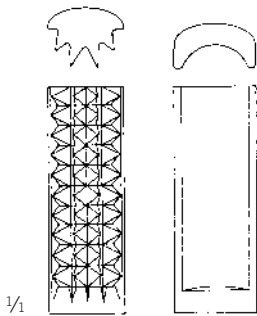

1/4

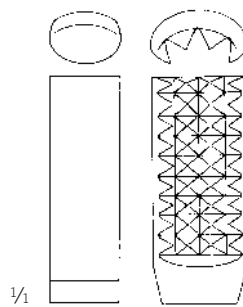

1/4

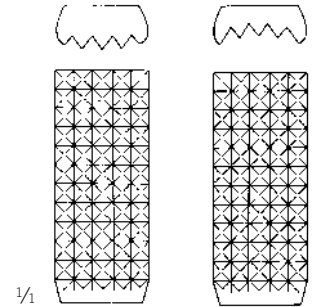

1/4



1/2

Maul
 jaw
 boca
 mors
 bocca
30 x 12 mm
 konvex konkav
 convex concave
 convexo concávo
 convexe concave
 convesso concavo



1/2

Maul
 jaw
 boca
 mors
 bocca
30 x 13,5 mm
 konkav konvex
 concave convex
 concávo convexo
 convexe concave
 concavo convesso



1/2

Maul
 jaw
 boca
 mors
 bocca
30 x 13,5 mm
 flach flach
 flat flat
 plano plano
 convexe concave
 plano plano

Obwegeser
 48-220-01-07
 18 cm 7¹ s

Obwegeser
 48-220-02-07
 18 cm 7¹ s

Obwegeser
 48-220-03-07
 18 cm 7¹ s

Hauthäkchen, Kopfhautklemme

Skin Hooklet, Scalp Clamp

Ganchito para piel, Pinza para cabelludo

Crochet pour peau, Pince pour le cuir chevelu

Gancio per cute, Pinza per cuoio capelluto



Tessier
48-250-19-07

19 cm 7⁴/₈

scharf
sharp
agudo
pointu
acuto

Atrauma



Tessier
48-252-13-07

13,5 cm 5³/₈

Nasenspekula

Nasal Specula
spéculos nasales
Spéculums nasaux
Specoli nasali

Mund-, Kiefer- und Gesichtschirurgie

Oral Maxillo-facial Surgery
Cirugía oral y maxilofacial
Chirurgie buccale et maxillo-faciale
Chirurgia maxillo-facciale

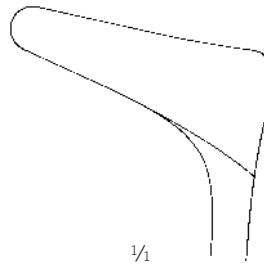

1/1

48-261-30-07

13,5 cm 5 3/8

Blätter
blades
hojas
lames
lame
35 mm

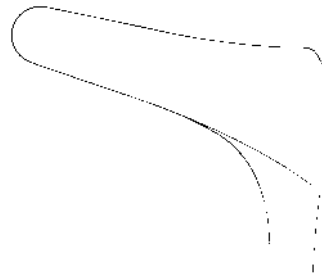

48-261-45-07

14 cm 5 4/8

Blätter
blades
hojas
lames
lame
45 mm



1/2

Tessier
48-261-30-07 -
48-261-70-07

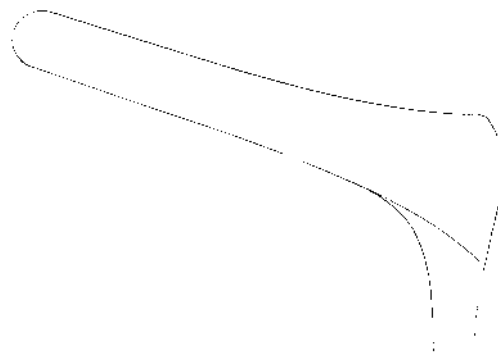

48-261-70-07

15,5 cm 6 1/8

Blätter
blades
hojas
lames
lame
70 mm

Osteotome

Osteotomes

Osteótomos

Ostéotomes

Osteotomo



1/2

Tessier
48-270-02-07 -
48-271-10-07

16 cm 6 2/8



1/1

48-270-02-07
2 mm



48-270-03-07
3 mm



48-270-05-07
5 mm



48-270-07-07
7 mm



48-270-10-07
10 mm

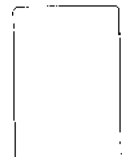

48-270-14-07
14 mm

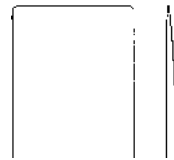

48-270-16-07
16 mm



48-271-05-07
5 mm



48-271-07-07
7 mm

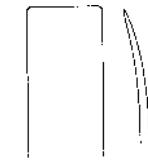

48-271-10-07
10 mm



1/2

Tessier
48-272-18-07

16 cm 6 2/8



1/1

18 mm



1/2

Tessier
48-273-10-07

18 cm 7 1/8

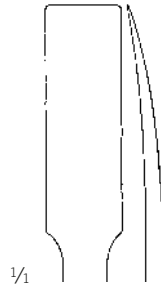

1/1

10 mm

Osteotome

Osteotomes
Osteótomos
Ostéotomes
Osteotomo

Mund-, Kiefer- und Gesichtschirurgie

Oral Maxillo-facial Surgery
Cirugía oral y maxilofacial
Chirurgie buccale et maxillo-faciale
Chirurgia maxillo-facciale



Tessier

48-274-10-07 - 48-275-15-07

20 cm 7 7/8

zur Transplantatentnahme aus Ilium und Tibia
for taking grafts from ilium and tibia
par sacar transplantes del ilion y la tibia
pour prise de greffon de l'ilion et du tibia
per prendere innesti dall'ileo e tibia

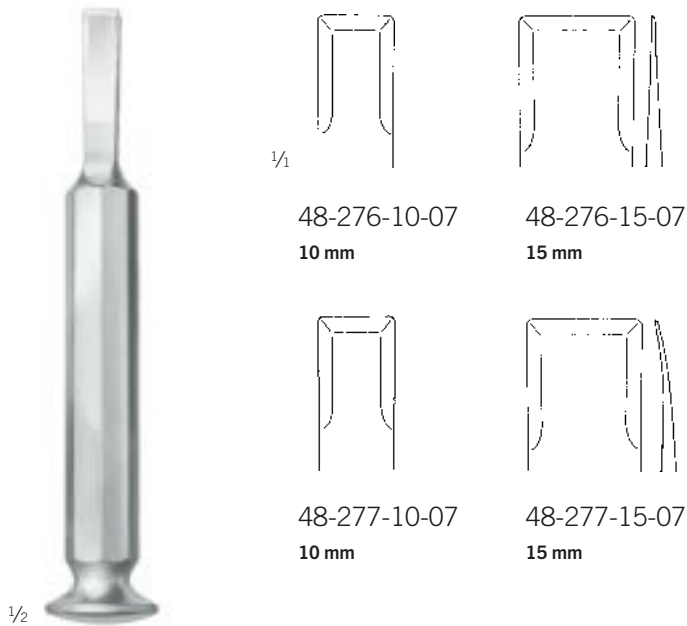

Tessier

48-276-10-07 - 48-277-15-07

16 cm 6 2/8

zur Transplantatentnahme aus der Calva
for taking grafts from the calva
par sacar transplantes del calvo
pour prise de greffon du crâne
per prendere innesti dal calvo

Thoraxhaken

Thoracic Retractors
Separadores torácico
Rétracteur thoracique
Divaricatore per torace

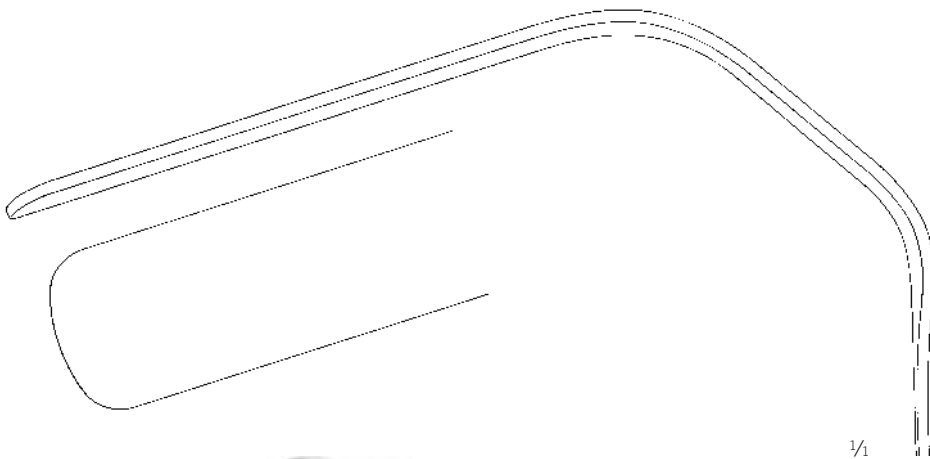

1/1

48-285-20-07

21 cm 8²₈

90 x 22 mm

48-285-28-07

26,5 cm 10³₈

120 x 28 mm



1/2

Tessier
48-285-20-07 -
48-285-28-07

Beckenkammspatel

Iliac Crest Retractors
Separadores para cresta ilíaca
Rétracteur iliaque
Divaricatore per cresta iliaca

Mund-, Kiefer- und Gesichtschirurgie

Oral Maxillo-facial Surgery
Cirugía oral y maxilofacial
Chirurgie buccale et maxillo-faciale
Chirurgia maxillo-facciale

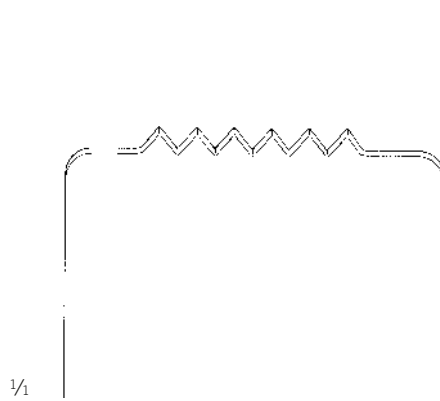

48-287-01-07
16,5 cm 6⁴₈
36 x 50 mm

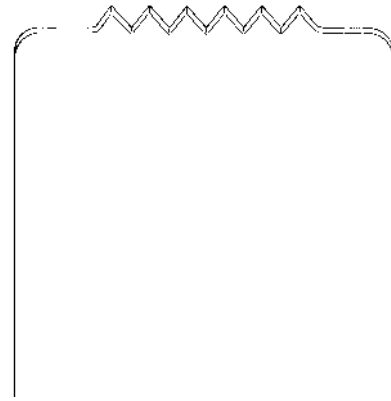

48-287-02-07
17,5 cm 6⁷₈
52 x 50 mm

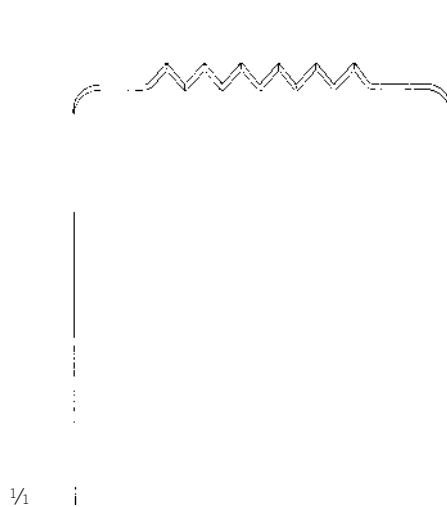

48-287-03-07
17,5 cm 6⁷₈
59 x 50 mm

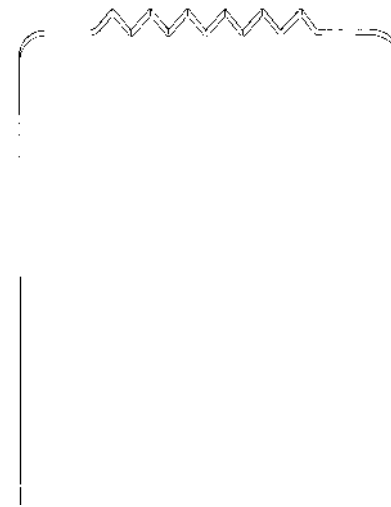

48-287-04-07
18 cm 7¹₈
66 x 50 mm



Tessier
48-287-01-07 -
48-287-04-07

Knochenhaltezangen, Knochensplitterzangen, Periostraspatorien

Bone Holding Forceps, Bone Cutting Forceps, Periosteal elevators

Pinzas para huesos, Cizallas para huesos, Legras para periostio

Pinces pour os, Pinces coupantes os, Rugine-raspatoires pour périoste

Pinze per ossa, Pinze per ossa, levatori periostali

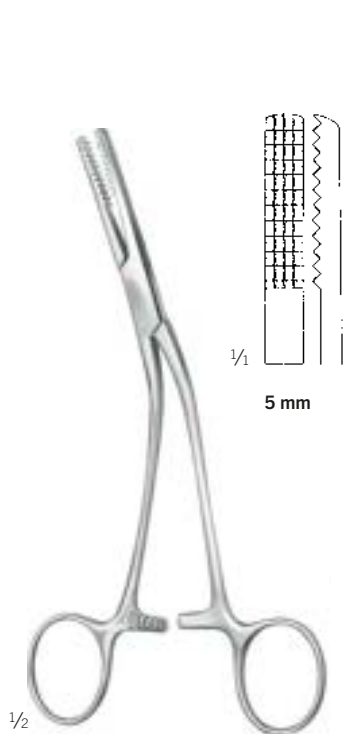

Tessier
48-291-15-07
16,5 cm 6⁴_a

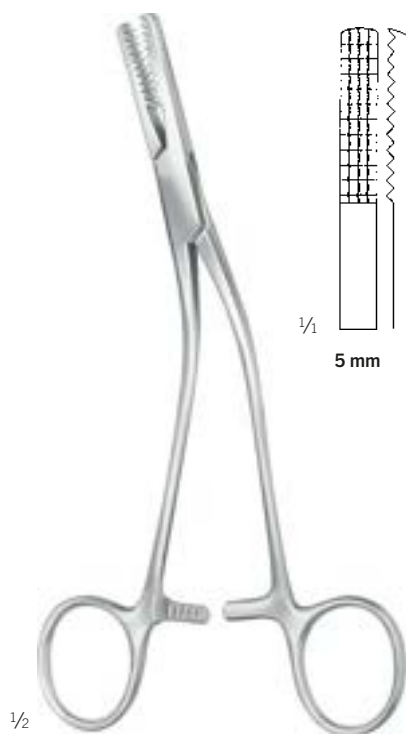

Tessier
48-293-19-07
18 cm 7¹_a



Tessier
48-300-20-07
18,5 cm 7²_a
schlankes Modell
slender pattern
modelo delgado
mod le gracile
modello delicato



Tessier
48-301-21-07
22 cm 8⁵_a

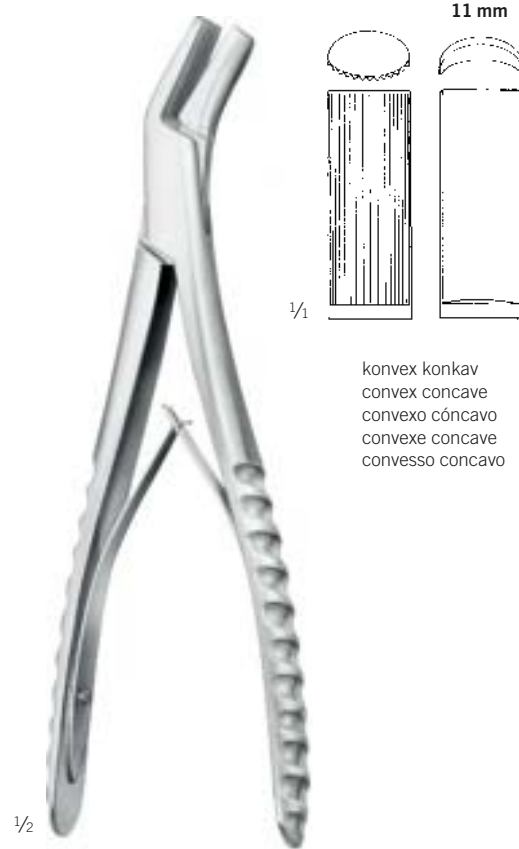

Tessier
48-303-22-07
22 cm 8⁵_a
Knochenformzange
Bone Contouring Forceps
Pinza para formar huesos
Pince pour former os
Pinza per formare osso

konvex konkav
convex concave
convexo cóncavo
convexe concave
convesso concavo

Ahlen, Spatel

Awls, Spatula
Leznas, spatulas
Ahles, Spatules
Puntruoli, Spatola

Mund-, Kiefer- und Gesichtschirurgie

Oral Maxillo-facial Surgery
Cirugía oral y maxilofacial
Chirurgie buccale et maxillo-faciale
Chirurgia maxillo-facciale

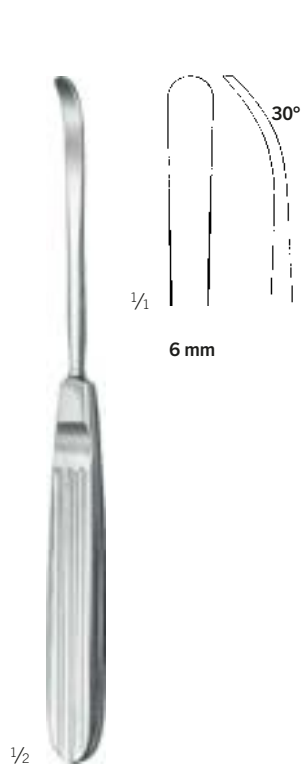

Tessier
48-311-01-07
18 cm 7 1/8

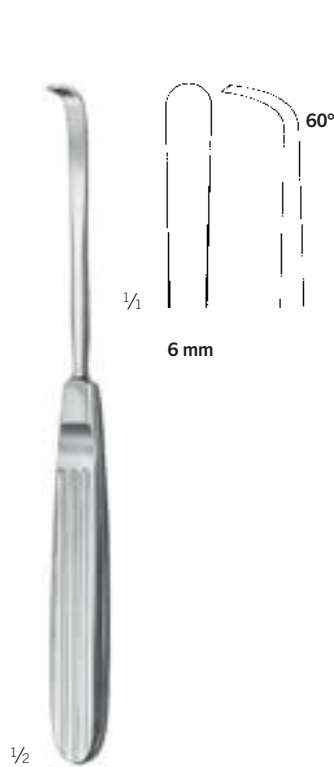

Tessier
48-311-02-07
18 cm 7 1/8

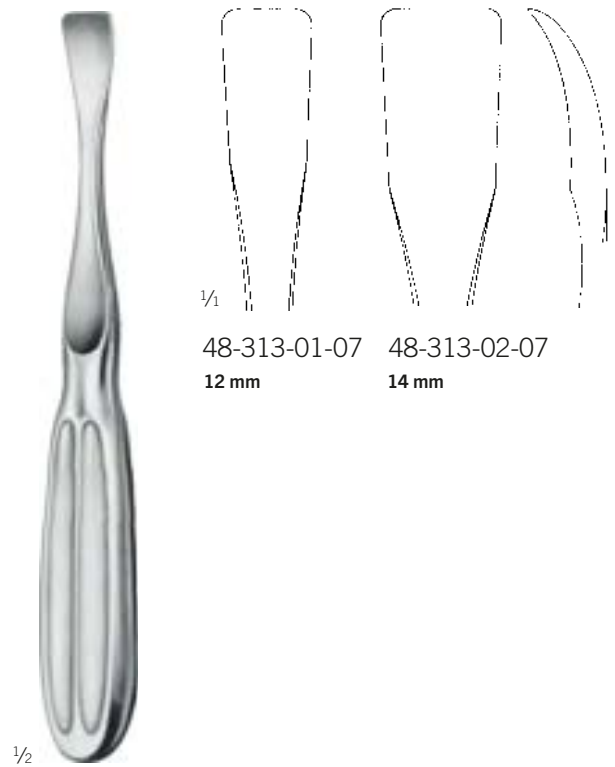

Tessier
48-313-01-07-
48-313-02-07
20,5 cm 8 1/8



Tessier
48-330-01-07
22 cm 8 5/8
10 - 12 mm
konisch, biegsam
conical, malleable
cónico, maleable
conique, malléable
conico, malleabili

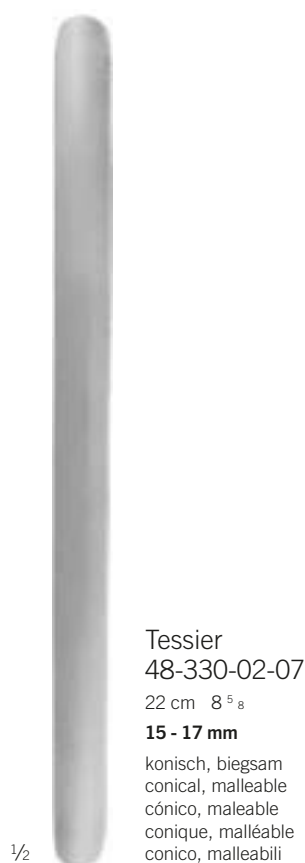

Tessier
48-330-02-07
22 cm 8 5/8
15 - 17 mm
konisch, biegsam
conical, malleable
cónico, maleable
conique, malléable
conico, malleabili



Tessier
48-330-03-07
22 cm 8 5/8
20 - 22 mm
konisch, biegsam
conical, malleable
cónico, maleable
conique, malléable
conico, malleabili

Weichteilhaken

Soft Tissue Retractors

Separadores para partes blandas

carteurs pour parties molles

Divaricatori per tessuti molli

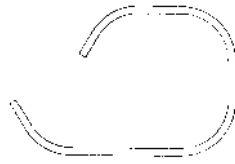

48-331-02-07

15 cm 5 ⁷/₈

20 x 13 / 30 x 15 mm

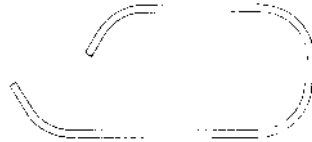

48-331-03-07

15,5 cm 6 ¹/₈

28 x 13 / 36 x 15 mm

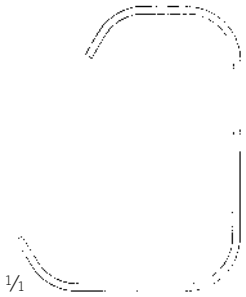

1/1

19 x 7 / 29 x 10 mm

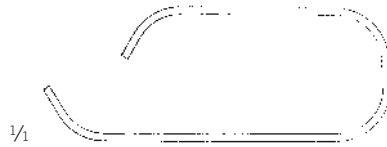

1/1

48-331-04-07

15,5 cm 6 ¹/₈

33 x 12 / 43 x 15 mm

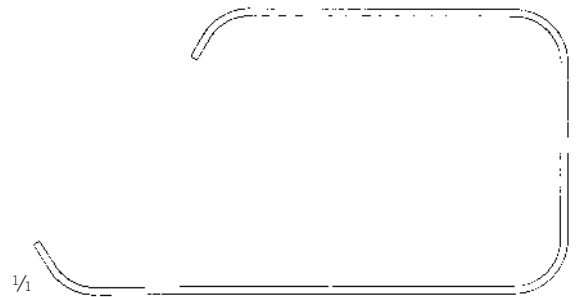

1/1

50 x 12 / 68 x 16 mm



1/2

Tessier
48-331-01-07

15 cm 5 ⁷/₈



1/2

Tessier
48-331-02-07 -
48-331-04-07



1/2

Tessier
48-331-05-07

16 cm 6 ²/₈

Weichteilhaken

Soft Tissue Retractors
Separadores para partes blandas
carteurs pour parties molles
Divaricatori per tessuti molli

Mund-, Kiefer- und Gesichtschirurgie

Oral Maxillo-facial Surgery
Cirugía oral y maxilofacial
Chirurgie buccale et maxillo-faciale
Chirurgia maxillo-facciale



48-333-03-07

15 cm 5⁷/₈

30 x 12 / 38 x 16 mm

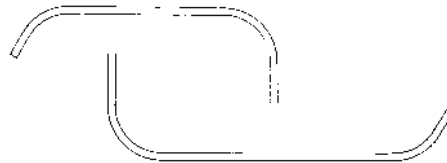

48-333-04-07

15 cm 5⁷/₈

35 x 12 / 45 x 16 mm

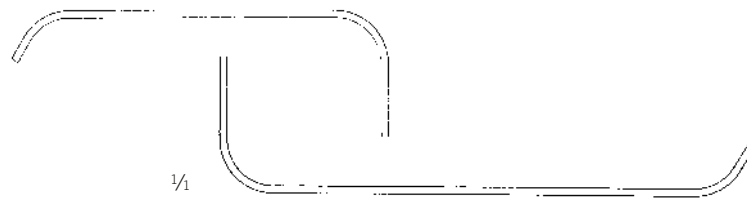

48-333-05-07

16 cm 6²/₈

50 x 12 / 70 x 16 mm

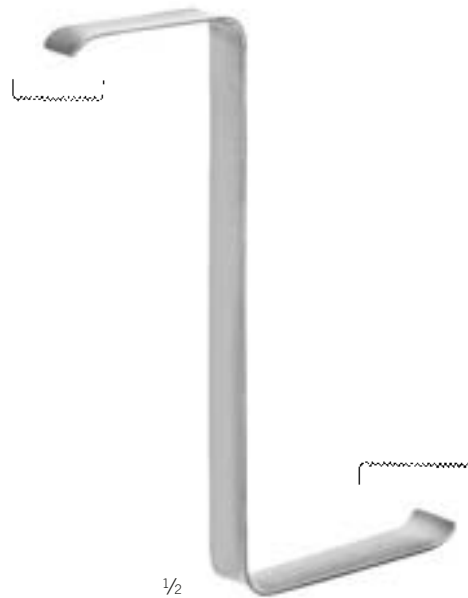

1/2

Tessier
48-333-03-07 -
48-333-05-07

Weichteilhaken

Soft Tissue Retractors

Separadores para partes blandas

carteurs pour parties molles

Divaricatori per tessuti molli



Fig. 1
48-335-01-07
8 mm

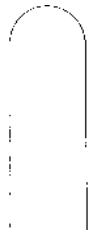

Fig. 2
48-335-02-07
10 mm

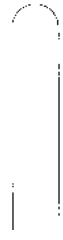

Fig. 3
48-335-03-07
7 mm

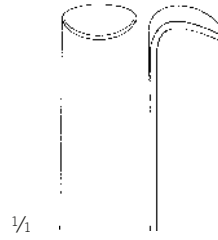

Fig. 4
48-335-04-07
10 mm



Fig. 5
48-335-05-07
8 mm



Fig. 6
48-335-06-07
12 mm



Tessier
48-335-01-07 -
48-335-03-07
12,5 cm 4⁷ s



Tessier
48-335-04-07 -
48-335-06-07
12,5 cm 4⁷ s

Osteotome

Osteotomes
Osteótomos
Ostéotomes
Osteotomo

Mund-, Kiefer- und Gesichtschirurgie

Oral Maxillo-facial Surgery
Cirugía oral y maxilofacial
Chirurgie buccale et maxillo-faciale
Chirurgia maxillo-facciale



1/2
Tessier
48-340-18-07
19 cm 7⁴/₈

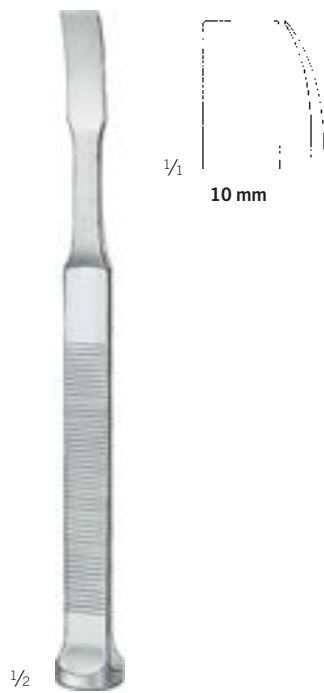

1/2
Tessier
48-341-18-07
18 cm 7¹/₈



1/2
48-350-24-07
22 cm 8⁵/₈

Präparierscheren, Drahtscheren

Dissecting Scissors, Wire Cutting Scissors

Tijeras para preparaciones, Tijeras para alambre

Ciseaux dissection, Ciseaux couper le fil

Forbici per dissezione, Tronchesino

TC GOLD

TC GOLD

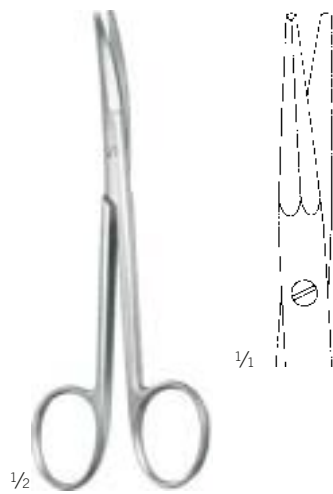

Tessier
48-351-13-07

13 cm 5¹/₈

Unterminierschere
Undermining Scissors
Tijera para minar
Ciseaux tunéliser
Forbici per tunnelare

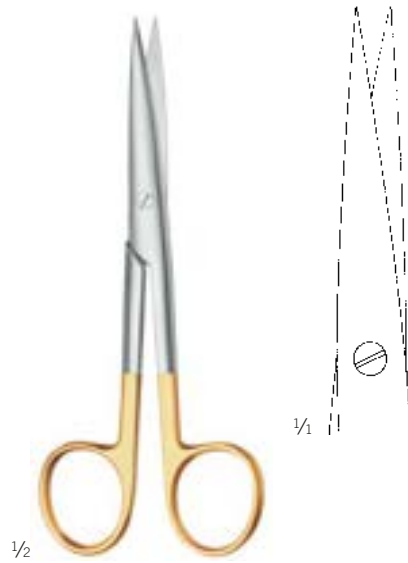

Tessier
48-352-14-07

15 cm 5⁷/₈

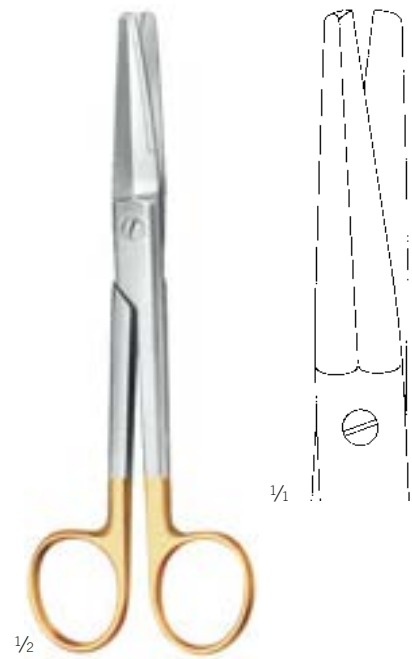

Tessier
48-354-16-07

16,5 cm 6⁴/₈

Repositionierzangen

Disimpaction Forceps

Pinzas de reposición

Pince repositionner

Pinze per riduzione

Mund-, Kiefer- und Gesichtschirurgie

Oral Maxillo-facial Surgery

Cirugía oral y maxilofacial

Chirurgie buccale et maxillo-faciale

Chirurgia maxillo-facciale



1/2

Tessier
48-360-01-07 -
48-362-02-07
23 cm 9

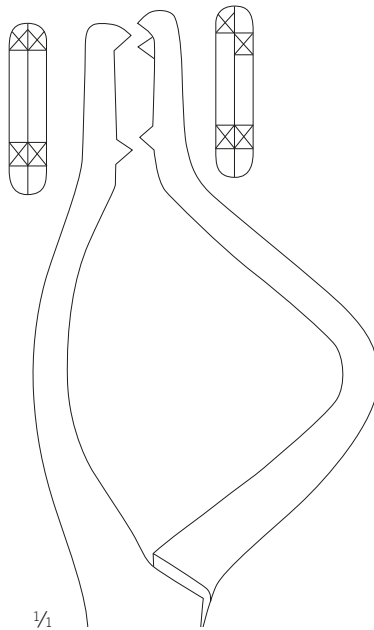

1/1

48-360-01-07

links, für Kinder
left, for children
izquierda, para ni os
gauche, pour enfants
sinistra, per bambini

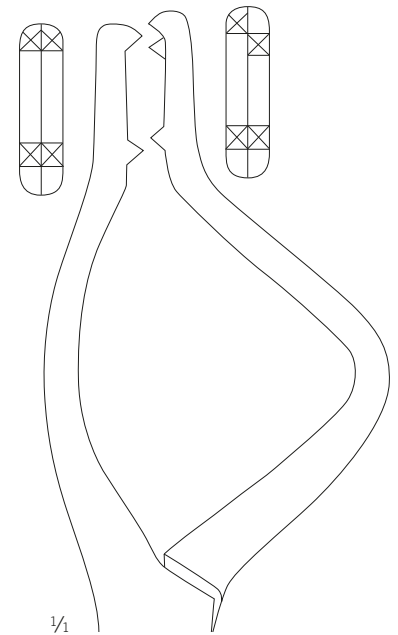

1/1

48-360-02-07

links, für erwachsene
left, for adults
izquierda, para adultos
gauche, pour adultes
sinistra, per adulti

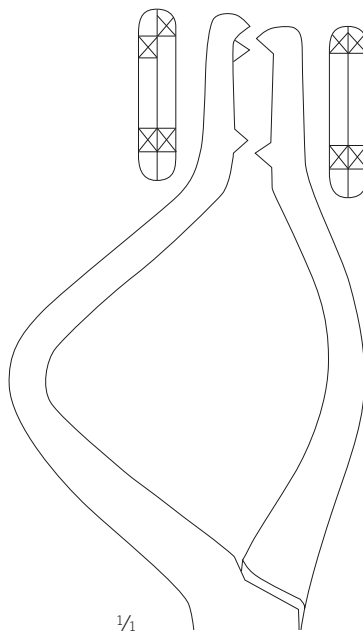

1/1

48-362-01-07

rechts, für Kinder
right, for children
derecha, para ni os
droite, pour enfants
destraper bambini

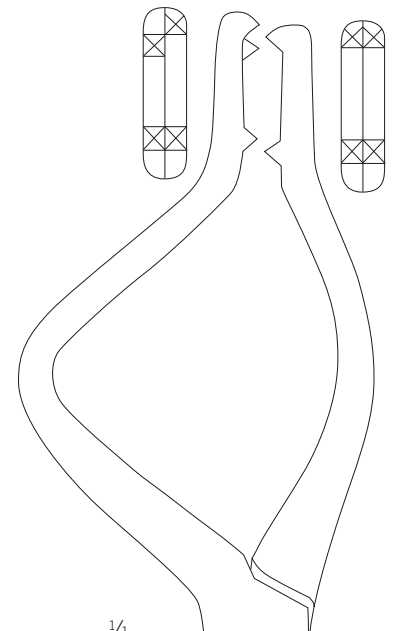

1/1

48-362-02-07

rechts, für erwachsene
right, for adults
derecha, para adultos
droite, pour adultes
destra, per adulti

Schieblehre, Knochenhaken

Caliper, Bone Hook
Calibre, Gancho para huesos
Calibre, Crochet pour os
Calibro, Gancio per ossa



1/2

Tessier
48-370-26-07

26 cm 10²/₈

Bereich
effective range
alcance eficaz
série effectif
rango effective
200 mm



1/2

Tessier
48-371-18-07

19 cm 7⁴/₈

schwarz verchromt
black chromium-plated
cromado en negro
chromé noir
cromato nero

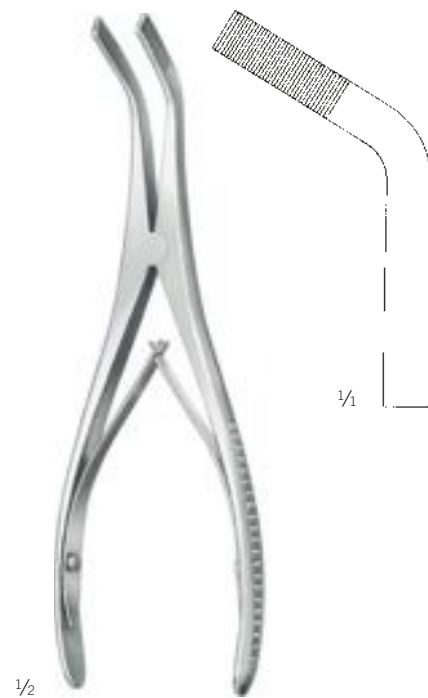

1/2

Tessier
48-376-18-07

17 cm 6⁶/₈

Spreizzange
Spreading Forceps
Pinza de expansión
Pince écarter
Pinze per allargare

Raspatorien

Periosteal levators
Periostótomos
Rugines-raspatoires
Periostotomi

Mund-, Kiefer- und Gesichtschirurgie

Oral Maxillo-facial Surgery
Cirugía oral y maxilofacial
Chirurgie buccale et maxillo-faciale
Chirurgia maxillo-facciale



1/2

Marchac
48-400-07-07 -
48-400-12-07
16 cm 6²₈

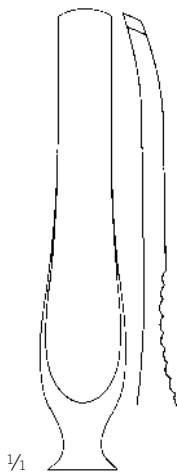

1/1

48-400-07-07
7,5 mm

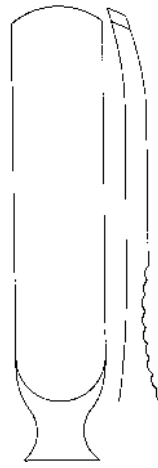

48-400-12-07
12 mm



1/2

Marchac
48-402-02-07 -
48-402-05-07
17 cm 6⁶₈



1/1

48-402-02-07
2 mm

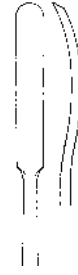

48-402-03-07
3,5 mm

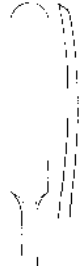

48-402-05-07
5 mm

Schablonen, Messlehre, Elevatorien

Templates, Caliper, elevators

Plantillas, Caliper, levadores

Gabarits, Calibre, levateurs

Sagome, Calibro, levatori



1/2

Marchac
48-405-00-07

Frontschablonen
Frontal Templates
Plantillas frontales
Gabarit frontal
Sagome frontali

für Kleinkinder
for infants
para bebés
pour bébés
per neonati



Marchac
48-405-01-07

Frontschablonen
Frontal Templates
Plantillas frontales
Gabarit frontal
Sagome frontali

für Kinder und Erwachsene
for children and adults
para niños y adultos
pour enfants et adultes
per bambini ed adulti



1/2

Marchac
48-420-00-07

Bereich
effective range
alcance eficaz
série effectif
rango effective

80 mm



1/2

1/1

Steinberg
48-500-18-07

18 cm 7 1/8

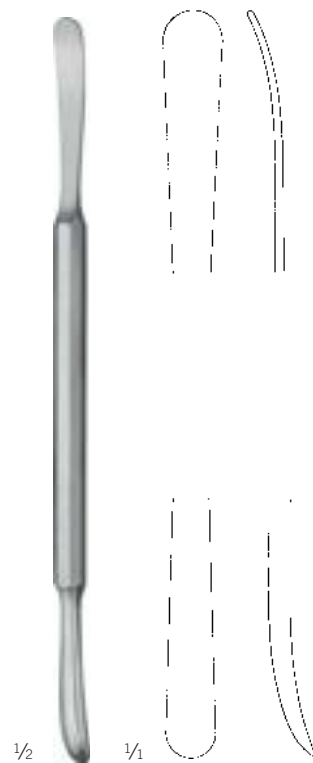

1/2

1/1

Steinberg
48-506-20-07

19,5 cm 7 5/8

Elevatorien

levators
levadores
levateurs
levatori

Mund-, Kiefer- und Gesichtschirurgie

Oral Maxillo-facial Surgery
Cirugía oral y maxilofacial
Chirurgie buccale et maxillo-faciale
Chirurgia maxillo-facciale

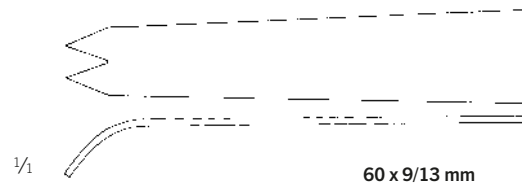

60 x 9/13 mm



Steinberg
48-525-23-07
22,5 cm 8⁷/₈

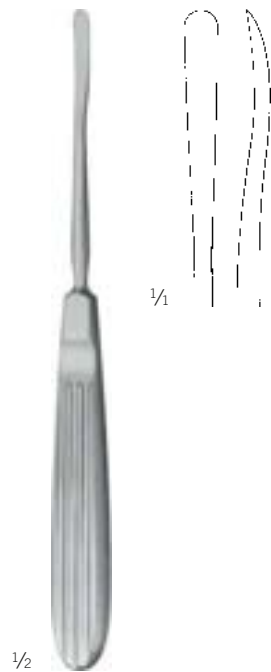

Steinberg
48-531-19-07
18,5 cm 7²/₈



Steinberg
48-541-60-07
22 cm 8⁵/₈

Instrumentarium Arnett FAB Orthognathie-System

Instrumentation Arnett FAB Orthognathic System

Instrumental sistema ortognático FAB Arnett

Instruments Arnett pour syst me d'orthognathie FAB

Strumenti per sistema di ortognazia Arnett FAB

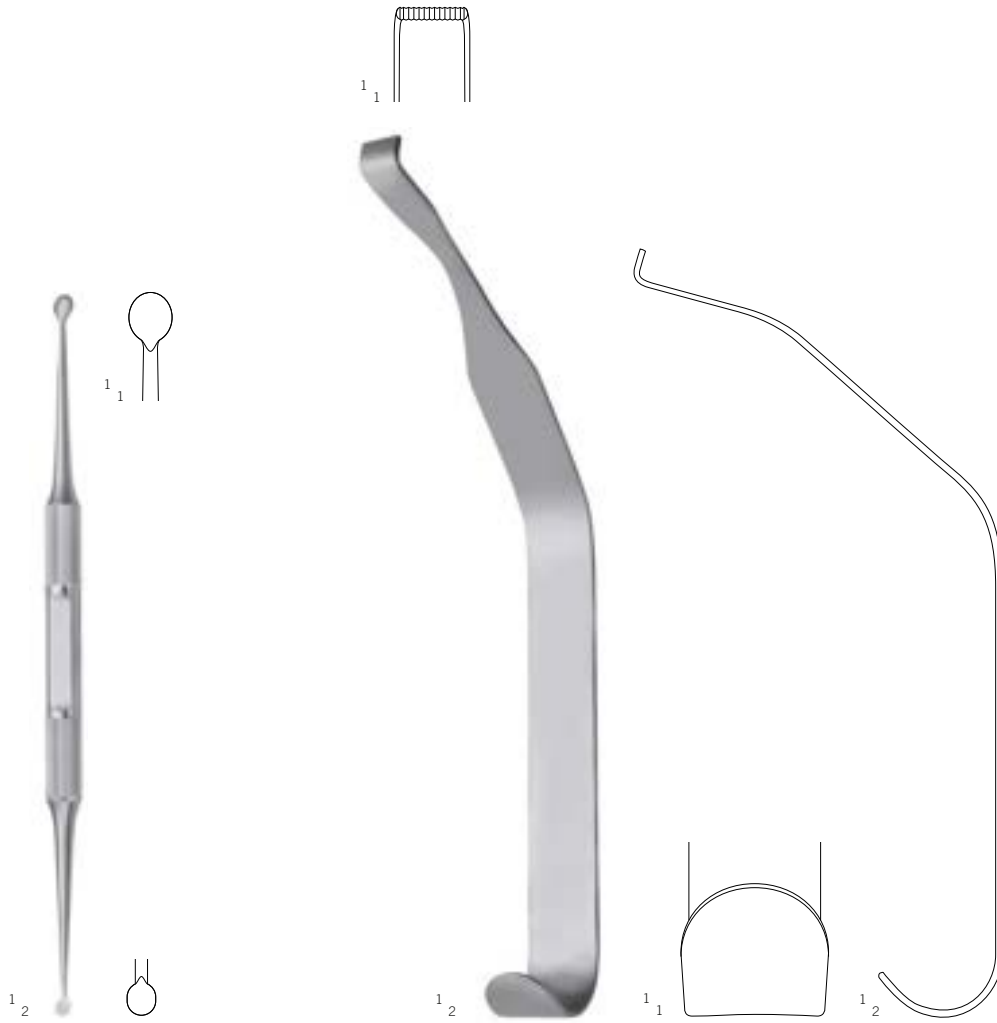

Arnett
48-703-19-07

19 cm 7⁴/₈

Kürette
Curette
Cucharillas
Curette
Curette

Arnett
48-704-22-07

20 cm 7⁷/₈

BSSO Lingual-Reaktor
BSSO Lingual retractor
Retractor lingual OSB
Rétracteur lingual BSSO
Separatore linguale BSSO

Instrumentarium Arnett FAB Orthognathie-System

Instrumentation Arnett FAB Orthognathic System
Instrumental sistema ortognático FAB Arnett
Instruments Arnett pour syst me d'orthognathie FAB
Strumenti per sistema di ortognazia Arnett FAB

Mund-, Kiefer- und Gesichtschirurgie

Oral Maxillo-facial Surgery
Cirugía oral y maxilofacial
Chirurgie buccale et maxillo-faciale
Chirurgia maxillo-facciale



Arnett
48-705-14-07

20 cm 7 7/8

BSSO TM -Platzierer
BSSO Condylar seating instrument
Posicionador ATM OSB
Instrument de positionnement ATM BSSO
Posizionatore per TM BSSO



Arnett
48-706-18-07

17 cm 6 6/8

Mandibular-Retraktor
Mandibular body retractor
Retractor mandibular
Rétracteur pour mandibule
Separatore mandibolare



Arnett
48-707-14-07

16,5 cm 6 4/8

Maxill re Sinus-Kürette
Maxillary sinus curette
Cureta para seno maxilar
Curette pour sinus maxillaire
Curetta per seno mascellare

Instrumentarium Arnett FAB Orthognathie-System

Instrumentation Arnett FAB Orthognathic System

Instrumental sistema ortognático FAB Arnett

Instruments Arnett pour syst me d'orthognathie FAB

Strumenti per sistema di ortognazia Arnett FAB

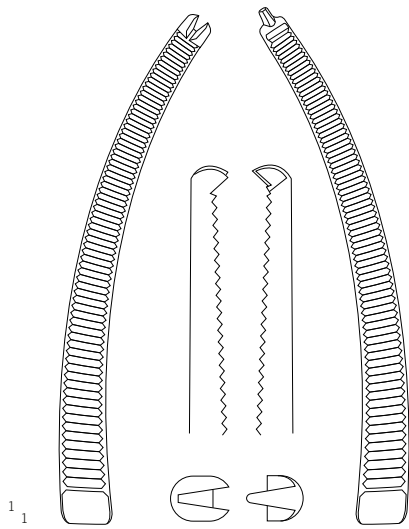

Arnett
48-708-01-07
Koronoid-Retraktor
Coronoid retractor
Retractor de coronoides
Rétracteur corono de
Separatore per coronoide

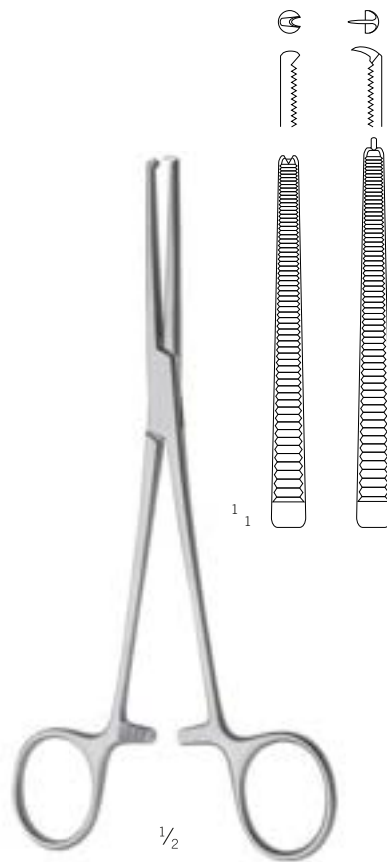

Arnett
48-708-14-07
18,5 cm 7 2/8
Knochenklemme
Bone Forceps
Pinza para huesos
Pince pour os
Pinza per ossa



Arnett
48-709-18-07
20 cm 7 7/8
Le Fort I Posterior-Retraktor
Le Fort I posterior retractor
Retractor posterior Le Fort I
Le Fort I Rétracteur postérieur
Separatore posteriore Le Fort I

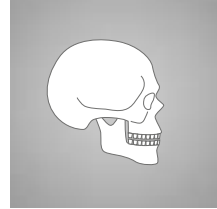

Arnett
48-711-22-07

22,5 cm 8⁷/₈

DBSSO Le Fort I
 Nerv-Dissektor

BSSO Le Fort I
 Nerve dissector

Disecador para
 nervios OSB Le Fort I

DBSSO Le Fort I
 Dissecteur de nerf

Dissettore per nervi
 BSSO Le Fort I

Arnett
48-711-23-07

23 cm 9

BSSO Alveolarnerv-
 Dissektor

BSSO Alveolar
 nerve dissector

Disecador para
 nervio alveolar OSB

Dissecteur de nerf
 alvéolaire BSSO

Dissettore per nervo
 alveolare BSSO

Arnett
48-711-24-07

23 cm 9

BSSO Alveolarnerv-
 Dissektor

BSSO Alveolar
 nerve dissector

Disecador para
 nervio alveolar OSB

Dissecteur de nerf
 alvéolaire BSSO

Dissettore per nervo
 alveolare BSSO

Arnett
48-711-25-07

23 cm 9

Le Fort I BSSO Retraktor
 für Inzissionsverschluss

Le Fort I BSSO Retractor
 for incision closure

Retractor Le Fort I
 OSB para cierre de incisiones

Le Fort I Rétracteur BSSO
 pour fermeture d'incision

Separatore Le Fort I
 BSSO per chiusura incisione

Arnett
48-712-12-07

20 cm 7⁷/₈

Le Fort I Septum-
 levatorium

Le Fort I Septum
 elevator

levador para
 septo Le Fort I

Le Fort I Iévateur
 pour septum

levatore setto
 Le Fort I

Instrumentarium Arnett FAB Orthognathie-System

Instrumentation Arnett FAB Orthognathic System

Instrumental sistema ortognático FAB Arnett

Instruments Arnett pour syst me d'orthognathie FAB

Strumenti per sistema di ortognazia Arnett FAB

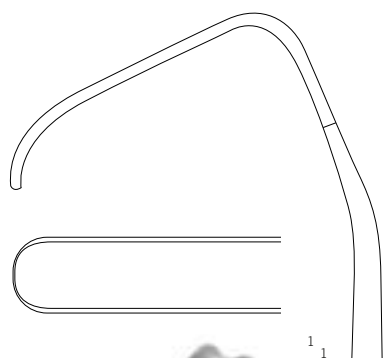

1 1

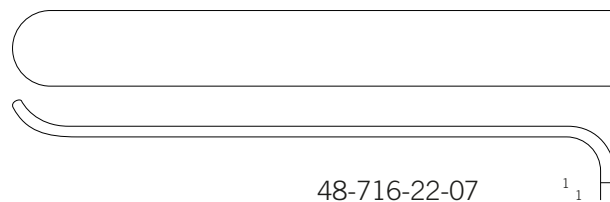

48-716-22-07
10 x 80 mm

1 1

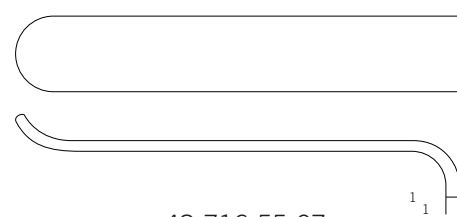

48-716-55-07
10 x 58 mm

1 1

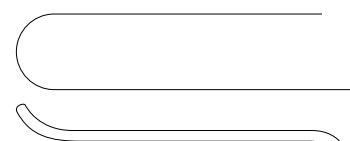

48-716-42-07
10 x 44 mm

1 1

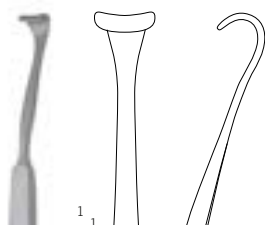

1 1

8 mm



1 2



1 2

Arnett
48-714-20-07

19,5 cm 7 5/8

BSSO Nerv-Retractor
BSSO Nerve retractor
Retractor para nervios OSB
Rétracteur de nerf BSSO
Separatore nervi BSSO

Arnett
48-715-42-07

22,5 cm 8 7/8

Le Fort I Oberlippen-Retractor
Le Fort I Upper lip retractor
Retractor para labio superior Le Fort I
Le Fort I carteur pour lèvre supérieure
Separatore labbro superiore Le Fort I

Arnett
48-716-22-07 - 48-716-55-07

22,5 cm 8 7/8

Wangen- und Lippen-Retractor
Cheek lip retractor
Retractor para mejillas y labios
carteur des lèvres et joues
Separatore per guance e labbra

Instrumentarium Arnett FAB Orthognathie-System

Instrumentation Arnett FAB Orthognathic System
Instrumental sistema ortognático FAB Arnett
Instruments Arnett pour syst me d'orthognathie FAB
Strumenti per sistema di ortognazia Arnett FAB

Mund-, Kiefer- und Gesichtschirurgie

Oral Maxillo-facial Surgery
Cirugía oral y maxilofacial
Chirurgie buccale et maxillo-faciale
Chirurgia maxillo-facciale

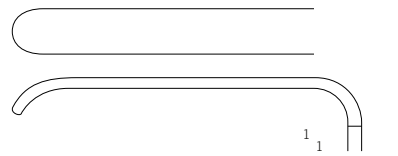

6,5 x 45 mm



¹/₂

Arnett
48-717-42-07

22 cm 8⁵/₈

Kinnosteotomie-Reaktor
Chin osteotomy retractor
Retractor para osteotomía mentoniana
Rétracteur pour génioplastie
Separatore per osteotomia del mento

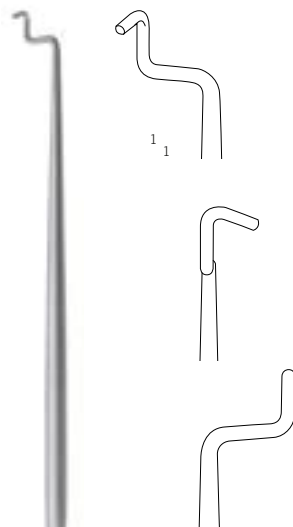

¹/₂

Arnett
48-723-22-07

22 cm 8⁵/₈

Le Fort I Interdental-Reaktor
Le Fort I Interdental retractor
Retractor interdental Le Fort I
Le Fort I Rétracteur interdentaire
Separatore interdental Le Fort I

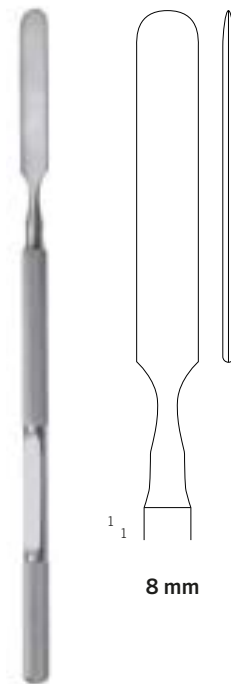

¹/₁

8 mm

¹/₂

Arnett
48-725-18-07

18 cm 7¹/₈

Interdental-Osteotom
Interdental osteotome
Osteótomo interdental
Ostéotome interdentaire
Osteotomo interdental

Instrumentarium Arnett FAB Orthognathie-System

Instrumentation Arnett FAB Orthognathic System

Instrumental sistema ortognático FAB Arnett

Instruments Arnett pour syst me d'orthognathie FAB

Strumenti per sistema di ortognazia Arnett FAB

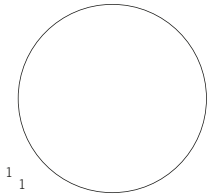

Ø = 25 mm



Arnett
48-727-20-07

20 cm 7⁷/₈

Hammer
Mallet
Martillo
Maillets
Martello

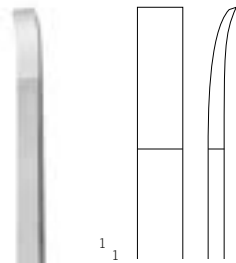

6 mm

1₂

Arnett
48-728-18-07

18 cm 7¹/₈

Pterygoid-Osteotom
Pterygoid osteotome
Osteótomo pterigoideo
Ostéotome ptérygo de
Osteotomo per pterigoido

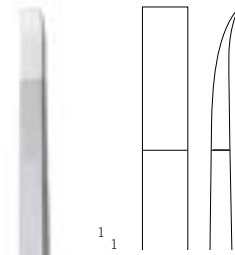

6 mm

1₂

Arnett
48-728-19-07

16 cm 6²/₈

BSSO Split-Osteotom
BSSO Splitting osteotome
Osteótomo Split OSB
Ostéotome de dédoublement BSSO
Osteotomo BSSO

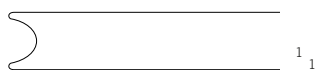

7 x 35 mm



Arnett
48-729-55-07

22 cm 8⁵/₈

BSSO Transoral-Re retraktor
BSSO Transoral retractor
Retractor transoral OSB
Rétracteur transoral BSSO
Separatore transorale BSSO



Arnett
48-731-14-07

14,5 cm 5⁶/₈

Me schieber
Caliper
Calibre
Calibre
Calibro a corsoio

Instrumentarium Arnett FAB Orthognathie-System

Instrumentation Arnett FAB Orthognathic System

Instrumental sistema ortognático FAB Arnett

Instruments Arnett pour syst me d'orthognathie FAB

Strumenti per sistema di ortognazia Arnett FAB

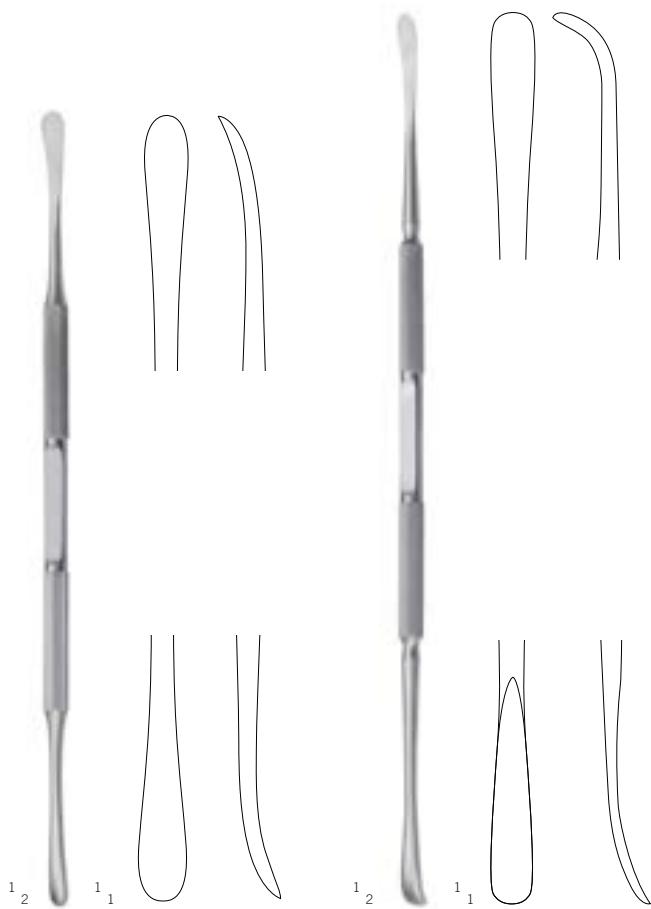

Arnett
48-731-22-07

21 cm 8²₈

Periostelevator
Periosteal elevator
levador perióstico
lévateur périoste
levatore per periosteo



Arnett
48-731-25-07

24 cm 9⁴₈

Periostelevator
Periosteal elevator
levador perióstico
lévateur périoste
levatore per periosteo

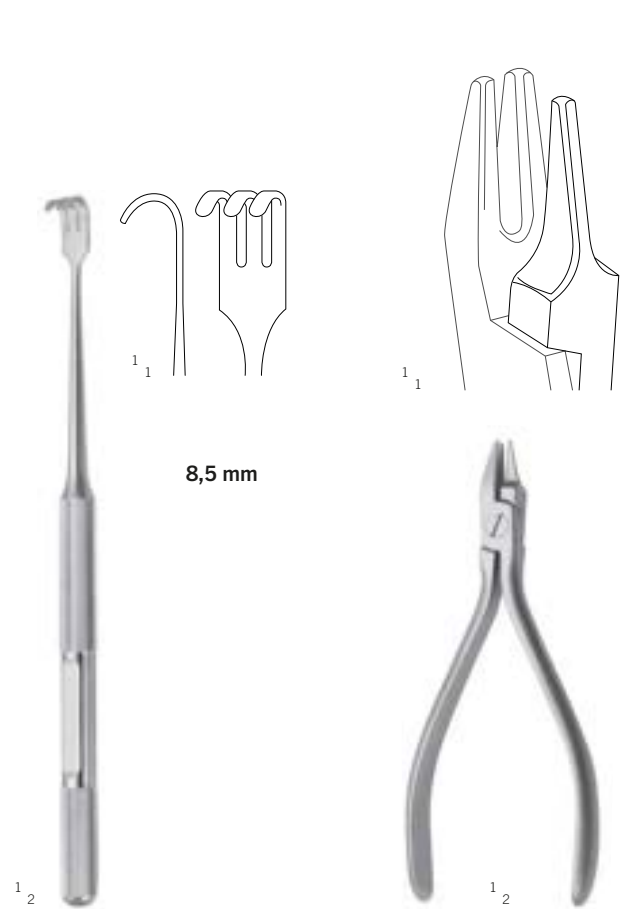

Arnett
48-735-19-07

19 cm 7⁴₈

Retraktor für Kinnosteotomie
Midline flap retractor
Retractor para osteotomía mentoniana
Rétracteur pour génioplastie
Separatore per osteotomia del mento



Arnett
48-738-12-07

12,5 cm 4⁷₈

Plattenbiegezange
Plate bending forceps
Alicate para doblar placas
Pince de pliage
Pinza per piegare placche

Instrumentarium Arnett FAB Orthognathie-System

Instrumentation Arnett FAB Orthognathic System
Instrumental sistema ortognático FAB Arnett
Instruments Arnett pour syst me d'orthognathie FAB
Strumenti per sistema di ortognazia Arnett FAB

Mund-, Kiefer- und Gesichtschirurgie

Oral Maxillo-facial Surgery
Cirugía oral y maxilofacial
Chirurgie buccale et maxillo-faciale
Chirurgia maxillo-facciale

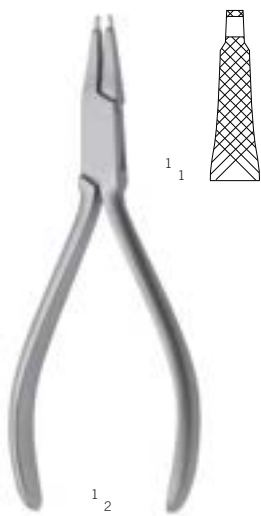

Arnett
48-738-13-07

13 cm 5¹/₈

Le Fort I Plattenbiegezange
Le Fort I Plate bending forceps
Alicate para doblar placas Le Fort I
Le Fort I Pince de pliage
Pinza per piegare placche Le Fort I

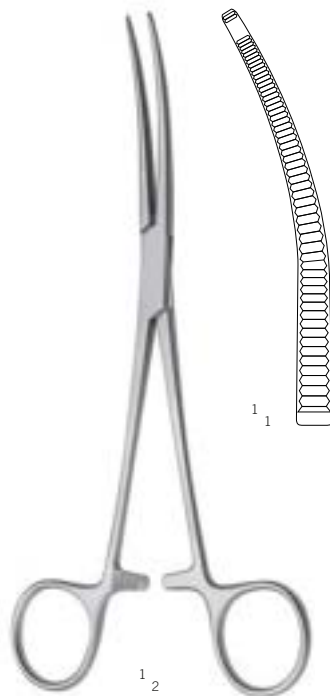

Arnett
48-739-18-07

18,5 cm 7²/₈

Plattenhalteklamme
Plate carrier
Pinza para sujetar placas
Pince de maintien
Pinza ferma-placche



Arnett
48-740-20-07

18,5 cm 7²/₈

Le Fort I Retraktor für nasale Mukosa
Le Fort I Nasal mucosa retractor
Retractor Le Fort I para mucosa nasal
Le Fort I Rétracteur pour muqueuse nasale
Separatore Le Fort I per mucosa nasale

Ösenzange

yelet forceps
Alicate de orificios
Pince de trous
Pinza di fori

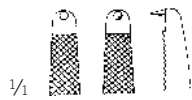
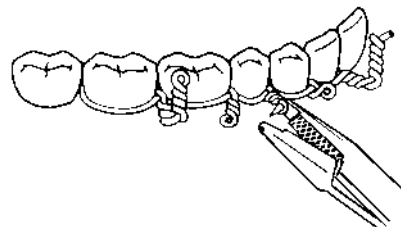
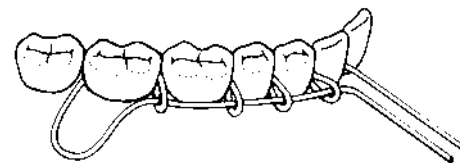
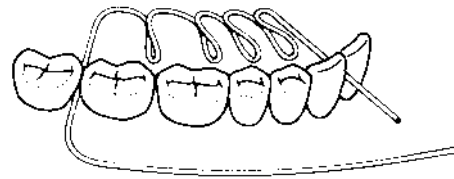

1/2

Obwegeser
48-756-15-07
15 cm 5 7/8

Aspirations-Dissektor, Osteotome

Suction Dissector, Osteotomes
 Disecador de aspiración, Osteótomos
 Dissecteur aspiration, Osteotomes
 Dissettore a aspirazione, Osteotomi

Mund-, Kiefer- und Gesichtschirurgie

Oral Maxillo-facial Surgery
 Cirugía oral y maxilofacial
 Chirurgie buccale et maxillo-faciale
 Chirurgia maxillo-facciale



50-440-04-07
4 mm

50-440-06-07
6 mm

50-440-08-07
8 mm

50-441-06-07
6 mm

Marchac
 50-440-04-07 -
 50-440-08-07
 18,5 cm 7²/₈

Marchac
 50-441-06-07
 18,5 cm 7²/₈



Marchac
 50-446-19-07
 20 cm 7⁷/₈



Marchac
 50-450-17-07
 17,5 cm 6⁷/₈
 Knochenspreizzange
 Bone xpander
 Pinza para separar huesos
 Pince pour séparer os
 Pinza per separare ossa

Universal-Schrauben-Explantationssystem

Universal Screw Removal System

Sistema universal de extracción de tornillos

Système universel d'explantation des vis

Sistema universale di rimozione delle viti

Kranio-maxillofaziale Osteosynthese-Systeme sind von vielen Herstellern erhältlich. Die eingesetzten Schrauben sind mit einem Durchmesser von 0,8 bis 3,5 mm lieferbar. Die am häufigsten verwendeten Schrauben sind Einfachschlitz, Centre Drive®, Kreuzschlitz Philips und Innen-sechskant.

Das KLS-Martin-Universal-Schrauben-Explantationssystem bietet 16 auswechselbare Schraubendreherklingen in einem Set, das die einfache Explantation aller gängigen kranio-maxillofazialen Osteosyntheseschrauben ermöglicht.

Cranio-maxillofacial osteosynthesis systems are available from numerous manufacturers. Micro screws and mini screws etc. are available in diameters ranging from 0.8 mm through 3.5 mm. The most common screw head configurations are Single Slot, Centre Drive®, Cruciate Philips and Hexagonal Socket.

The KLS Martin universal screw removal system provides 16 interchangeable screwdriver blades in one compact kit allowing the easy removal of virtually any common cranio-maxillofacial osteosynthesis screw.

Los sistemas de osteosíntesis craneomaxilofaciales pueden obtenerse de muchos fabricantes. Los microtornillos, minitornillos, etc. están disponibles con diámetros de 0,8 hasta 3,5 mm. Los tornillos más utilizados son los de ranura simple, Centre Drive®, ranura en cruz Philips y hexágono interior.

El sistema universal de extracción de tornillos KLS Martin ofrece 16 terminales intercambiables en un juego, que permite la sencilla extracción de todos los tornillos craneomaxilofaciales corrientes para la osteosíntesis.



50-600-00-04

Set, komplett
Set, complete
Juego, completo
Jeu, complet
Serie completa

	Set	Set	Juego	Jeu	Set
50-600-00-04	Universal-Schrauben-Explantationssystem, Komplettes Set: Lagerung mit Handgriff und Klingen 1-18	Universal screw removal system, Set complete: Storage with handle and blades 1-18	Sistema universal de extracción de tornillos, juego completo: Módulo con mango y los terminales 1-18	Système universel d'explantation de vis, Jeu complet: Module avec manche et les lames 1 a 18	Sistema universale di rimozione delle viti, Set completo: Modulo con manico e le lame 1-18
	Lagerung, bestehend aus:	Storage, consisting of:	Módulo, formado por:	Rangement, composé de	Supporto, consistente in
55-962-37-04	Doppel-Insertmodul, grau	Twin insert module, gray	Módulo de inserción doble, gris	Module d'inserts double, gris	Modulo inserto doppio, grigio:
55-964-31-04	Insert Schrauben-explantationsset (A) SD	Insert for screw removal set (A) SD	Bandeja para juego de extracción de tornillos (A), destornillador	Insert pour jeu d'explantation de vis (A), tournevis	Inserto set di rimozione delle viti (A), cacciavite
55-964-32-04	Insert Schrauben-explantationsset (B)	Insert for screw removal set (B)	Bandeja para juego de extracción de tornillos (B)	Insert pour jeu d'explantation de vis (B)	Inserto set di rimozione delle viti (B)
55-963-29-04	Deckel Schrauben-explantationsset	Lid for screw removal set	Tapa para juego de extracción de tornillos	Couvercle du jeu d'explantation de vis	Coperchio del set di rimozione delle viti

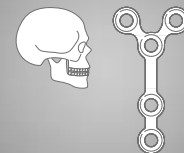

De nombreux fabricants proposent des systèmes d'ostéosynthèse craniomaxillofaciale. Les microvis et minivis etc. utilisées sont livrables avec un diamètre de 0,8 à 3,5 mm. Les vis les plus fréquemment utilisées sont des vis à fente simple, Centre Drive®, cruciformes (Phillips) et à six pans creux.

Le système universel d'explantation de vis KLS Martin propose 16 lames de tournevis interchangeables dans un jeu qui permet l'explantation simple de toutes les vis d'ostéosynthèse craniomaxillofaciale.

I sistemi di osteosintesi cranio-maxillofaciale si possono ottenere da molti produttori. Le microviti o miniviti sono disponibili con un diametro da 0,8 a 3,5 mm. Le viti utilizzate più frequentemente sono le viti a brugola semplice Centre Drive®, con intaglio a croce Phillips e viti a esagono cavo.

Il sistema universale di rimozione delle viti, KLS Martin, offre 16 lame per cacciaviti intercambiabili in un set che consente una semplice rimozione di tutte le più comuni viti per osteosintesi cranio-maxillofaciale.



50-425-05-07

Schraubendreher-Handgriff, starr
Screwdriver handle, rigid
Mango de destornillador, rígido
Poignée de tournevis, rigide
Manico del cacciavite, rigido

Klinge Blade Terminal Lame Lama	Schraube Screw Tornillo Vis Vite	Schrauben- ansatz	Screw head socket	Cabeza tornillo	Empreinte de la tête de vis	Testa vite	
50-425-11-07	Nr. 1 1.5/2.0 mm	☉	Schlitz	slot	ranura	fente	fessura
50-425-12-07	Nr. 2 2.0/2.3 mm	☉	Centre Drive®	Centre Drive®	Centre Drive®	Centre Drive®	Centre Drive®
50-425-13-07	Nr. 3 1.3/2.4 mm	☉	Kreuzschlitz	cross-recessed	ranura en cruz	cruciforme	intaglio a croce
50-425-14-07	Nr. 4 2.7/3.5/4.0 mm	☉	Innensechskant	hexagon socket	hexágono interior	6 pans creux	esagono cavo
50-425-15-07	Nr. 5 2.0/2.7 mm	☉	Phillips	Phillips	Phillips	Phillips	Phillips
50-425-16-07	Nr. 6 0.8/1.0/1.2 mm	☉	Kreuzschlitz	cross-recessed	ranura en cruz	cruciforme	intaglio a croce
50-425-17-07	Nr. 7 1.5 mm	☉	Centre Drive®	Centre Drive®	Centre Drive®	Centre Drive®	Centre Drive®
50-425-18-07	Nr. 8 1.0 mm	☉	Centre Drive®	Centre Drive®	Centre Drive®	Centre Drive®	Centre Drive®
50-425-19-07	Nr. 9 2.7 mm	☉	Centre Drive®	Centre Drive®	Centre Drive®	Centre Drive®	Centre Drive®
50-425-20-07	Nr. 10 2.7 mm	☉	Schlitz	slot	ranura	fente	fessura
50-425-21-07	Nr. 11 2.0 mm	☉	Innensechskant	hexagon socket	hexágono interior	6 pans creux	esagono cavo
50-425-22-07	Nr. 12 2.3/2.7 mm	☉	Innensechskant	hexagon socket	hexágono interior	6 pans creux	esagono cavo
50-425-23-07	Nr. 13 alle/all/todos/ toutes/tutte		Knochen-Explantation	bone explantation blade	explantación ósea	explantation de l'os	espiazione ossea
50-425-25-07	Nr. 15 1.5 mm	☉	Torx/star/T-Drive T5	Torx/star/T-Drive T5	Torx/star/T-Drive T5	Torx/star/T-Drive T5	Torx/star/T-Drive T5
50-425-24-07	Nr. 16 2.0 mm	☉	Torx/star/T-Drive T6	Torx/star/T-Drive T6	Torx/star/T-Drive T6	Torx/star/T-Drive T6	Torx/star/T-Drive T6
50-425-26-07	Nr. 17 2.5 mm	☉	Torx/star/T-Drive T7	Torx/star/T-Drive T7	Torx/star/T-Drive T7	Torx/star/T-Drive T7	Torx/star/T-Drive T7
50-425-27-07	Nr. 18 2.7/3.5 mm	☉	Torx/star/T-Drive T8	Torx/star/T-Drive T8	Torx/star/T-Drive T8	Torx/star/T-Drive T8	Torx/star/T-Drive T8

Spezial-Produkte

Special Products

Productos especiales

Produits spéciaux

Prodotti speciali

Unser Ordner-System „Craniomaxillofacial Surgery“ enthält die gesamte Palette der KLS-Martin-Implantate und -Instrumente für die Mund-, Kiefer- und Gesichtschirurgie.

Our folder system “Craniomaxillofacial Surgery” contains the full range of KLS-Martin implants and instruments for cranio-maxillofacial surgery.

Nuestro sistema de carpetas “Craniomaxillofacial Surgery” incluye la gama completa de implantes e instrumentos de KLS-Martin para la cirugía oral y maxilofacial.

Notre système de dossiers «Craniomaxillofacial Surgery» contient l'ensemble de la palette des implants et instruments KLS Martin pour la chirurgie buccale et maxillofaciale.

Il nostro sistema di cartelle “Craniomaxillofacial Surgery” contiene la gamma completa degli impianti e degli strumenti di KLS Martin per la chirurgia orale-maxillo-facciale.

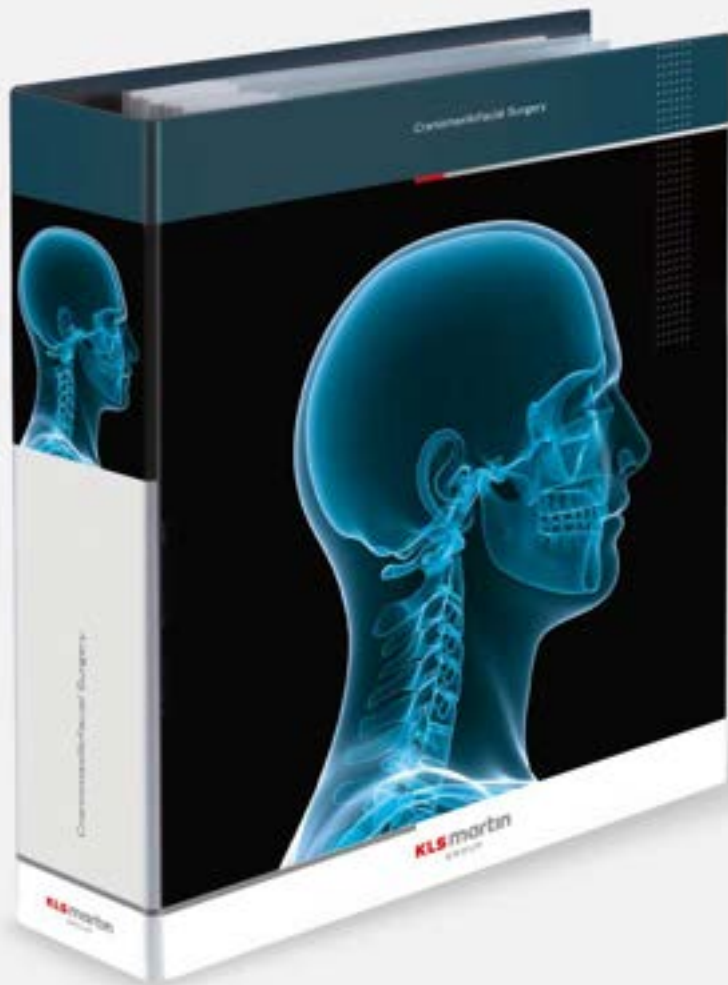
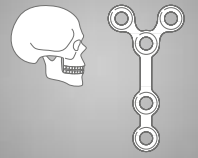

Distraktion in der oral- und kranio-maxillofazialen Chirurgie

Basierend auf den Grundlagen von Ilizarov ist die vertikale Distraktion des Alveolarkamms durch besonders konstruierte Distraktoren für die erfolgreiche Behandlung von Knochendefekten zum Stand der Technik geworden. Das Verfahren wird als sehr wertvolle Technik in Fällen von frühzeitigem Zahnverlust durch Parodontose oder Verletzungen betrachtet, da sie die knöchernen Basis wesentlich verbessert und somit mehr Halt für eine bessere Verankerung von Dentalimplantaten ermöglicht. Außerdem garantiert es bessere ästhetische Ergebnisse im Vergleich zu den meisten konventionellen Augmentationstechniken.



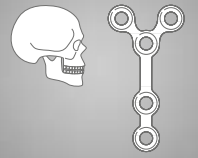

EN

Distraction in oral and cranio-maxillofacial surgery

Based on Ilizarov's technique, vertical distraction of the alveolar ridge by especially designed distraction devices has become a state-of-the-art method for the successful treatment of such bone defects. It is considered a highly valuable technique in cases of premature teeth loss due to periodontal disease or injury, as it significantly improves the basis for substance meaning more support and better fixation of dental implants. It also ensures better aesthetic results compared to most conventional augmentation techniques.

ES

Distracción en cirugía oral y cráneo-maxilofacial

Basada en la técnica de Ilizarov, la distracción vertical de la cresta alveolar mediante dispositivos de distracción de diseño especial se ha convertido en un método de referencia para el tratamiento exitoso de defectos óseos de este tipo. Se considera una técnica muy valiosa en casos de pérdida dental prematura debido a periodontitis o lesiones, ya que mejora de forma significativa la base para el sustrato, lo que significa mayor apoyo y mejor fijación de los implantes dentales. También garantiza mejores resultados estéticos que la mayoría de las técnicas de aumento convencionales.

FR

Distraction dans la chirurgie orale et crânio-maxillo-faciale

Sur la base de la technique d'Ilizarov, la distraction verticale de la crête alvéolaire à l'aide de dispositifs de distraction spécialement conçus est devenue une méthode de pointe pour le traitement réussi de tels défauts osseux. Considérée comme une technique de grande valeur dans les cas de perte prématurée de dents en raison d'une maladie ou d'une lésion parodontale, elle améliore de manière significative la base de substance, permettant ainsi un meilleur support et une fixation plus ferme d'implants dentaires. Elle garantit aussi de meilleurs résultats esthétiques par rapport à la plupart des techniques d'augmentation conventionnelles.

IT

La distrazione nella chirurgia orale e cranio-maxillofacciale

Sulla base della tecnica di Ilizarov, la distrazione verticale del margine alveolare mediante dispositivi appositamente progettati è oggi il metodo all'avanguardia per il successo del trattamento di questi difetti ossei. È una tecnica estremamente apprezzata in caso di perdita pre-coce di denti dovuta a malattia parodontale o traumi, poiché migliora significativamente la base della sostanza dentale, con conseguente maggiore supporto e migliore fissaggio degli impianti protesici. Garantisce anche migliori risultati estetici rispetto alle tecniche di aumento osseo tradizionali.

SonicWeld Rx® – Die Revolution der Osteosynthese

KLS Martin hat mit SonicWeld Rx® ein revolutionäres System für die Kieferknochenaugmentation entwickelt. Mit modernster Ultraschalltechnik, kombiniert mit resorbierbaren Implantaten, wird die Metallentfernung überflüssig. Dank des völlig neuen Verschweißungsprozesses verankert sich das resorbierbare Material tief in der Knochenstruktur und erzeugt eine bislang ungekannte Primärstabilität. In der präprothetischen Augmentation eignet sich das System für resorbierbare Membranfixierungen (Guided Bone Regeneration), Auflagerungen (Onlay Grafts) und Schalungen (Split Grafts).



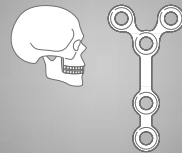

EN

SonicWeld Rx® – The revolution in osteosynthesis

With SonicWeld Rx®, KLS Martin offers a revolutionary system for jaw bone augmentation. Highly advanced ultrasound technology combined with resorbable implants makes the metal removal redundant. Thanks to the completely novel welding technique, the bioabsorbable material penetrates deeply into the bone structure to provide a level of primary stability never seen before. In preprosthetic augmentation, this system can be used for resorbable membrane fixation (guided bone regeneration), appositions (onlay grafts) procedures based on the innovative shell technique (split grafts).

ES

SonicWeld Rx® – La revolución de la osteosíntesis

Con SonicWeld Rx®, KLS Martin ha diseñado un sistema revolucionario para el aumento del hueso maxilar. La más avanzada tecnología de ultrasonidos, combinada con implantes reabsorbibles, hace innecesaria la eliminación de metales. Gracias al innovador proceso de soldadura, el material reabsorbible se ancla profundamente en la estructura ósea y proporciona una estabilidad primaria sin precedentes. En el aumento preprotésico, este sistema es apropiado para fijaciones de membranas reabsorbibles (guided bone regeneration - regeneración ósea guiada), aposiciones (onlay grafts) y la técnica de valva (split grafts).

FR

SonicWeld Rx® – La révolution de l'ostéosynthèse

KLS Martin a mis au point, avec SonicWeld Rx®, un système révolutionnaire pour l'augmentation de la masse osseuse de la mâchoire. Avec une technique à ultrasons ultrasonique, associée à des implants résorbables, le retrait du métal devient superflu. Grâce au tout nouveau processus de soudage, le matériau résorbable s'ancre en profondeur dans la structure osseuse et génère une stabilité primaire jusqu'à présent inconnue. Dans le cadre de l'augmentation pré-prothétique, le système est adapté pour les régénérations osseuses guidées (guided bone regeneration), les greffes osseuses (onlay grafts) et les greffes fendues (split grafts).

IT

SonicWeld Rx® – La rivoluzione dell'osteosintesi

KLS Martin ha sviluppato con SonicWeld Rx® un sistema rivoluzionario per l'aumento dell'osso mascellare. La più moderna tecnologia ad ultrasuoni, abbinata a impianti riassorbibili, rende superflua la rimozione del metallo. Grazie al processo di saldatura completamente rinnovato, il materiale riassorbibile si ancora profondamente alla struttura ossea raggiungendo una stabilità primaria finora mai vista. Nella fase di aumento pre-protetica, questo sistema è indicato per fissaggi riassorbibili di membrane (guided bone regeneration), apposizioni (onlay grafts) e gusci (split grafts).

Verschiedenes
Miscellaneous
Diversos artículos
Articles divers
Articoli diversi

55-56

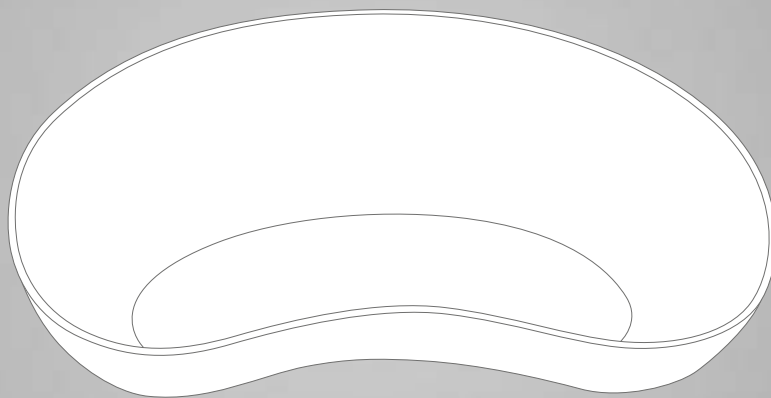

Spezial-Produkte

Special Products

Productos especiales

Produits spéciaux

Prodotti speciali

Unser Katalog „Steriltechnik“ enthält die gesamte Palette der KLS-Martin-Sterilisationscontainer- und Siebkorbssysteme.

Our catalog “Sterile Technology” contains the full range of KLS-Martin sterilizing containers and perforated sterilization baskets.

Nuestro catálogo “Técnica de esterilización” incluye la gama completa de contenedores de esterilización y sistemas de bandejas cribadas de KLS-Martin.

Notre catalogue «Technologie stérile» contient l'ensemble de la palette des conteneurs de stérilisation et paniers à mailles KLS Martin.

Il nostro catalogo “Tecnica di sterilizzazione” contiene la gamma completa dei sistemi di contenitori di sterilizzazione e vassoi reticolati di KLS Martin.



Verschiedenes

Miscellaneous

Diversos artículos

Articles divers

Articoli diversi



55-997-01-04

LubriPen

für präzises Ölen von chirurgischen Instrumenten und Medizinprodukten
for precise lubrication of surgical instruments and medical devices
para una lubricación perfecta de instrumentos quirúrgicos y dispositivos médicos
Graissage précis d'instruments chirurgicaux et d'équipements médicaux
Lubrificazione di precisione di strumenti chirurgici e dispositivi medici



56-231-04-01 -

56-231-18-01

Metallschalen

Stainless Steel Bowls

Cubetas de acero inoxidable

Cuvettes de acier inoxydable

Scodelle di acciaio inossidabile



	x h	
56-231-04-01	40 x 19 mm	20 ccm
56-231-06-01	61 x 30 mm	70 ccm
56-231-08-01	80 x 40 mm	140 ccm
56-231-11-01	116 x 50 mm	250 ccm
56-231-12-01	128 x 55 mm	350 ccm
56-231-14-01	147 x 65 mm	500 ccm
56-231-16-01	167 x 75 mm	900 ccm
56-231-18-01	187 x 85 mm	1.300 ccm

Laserchirurgie
Laser Surgery
Cirugía láser
Chirurgie laser
Chirurgia laser

76-79

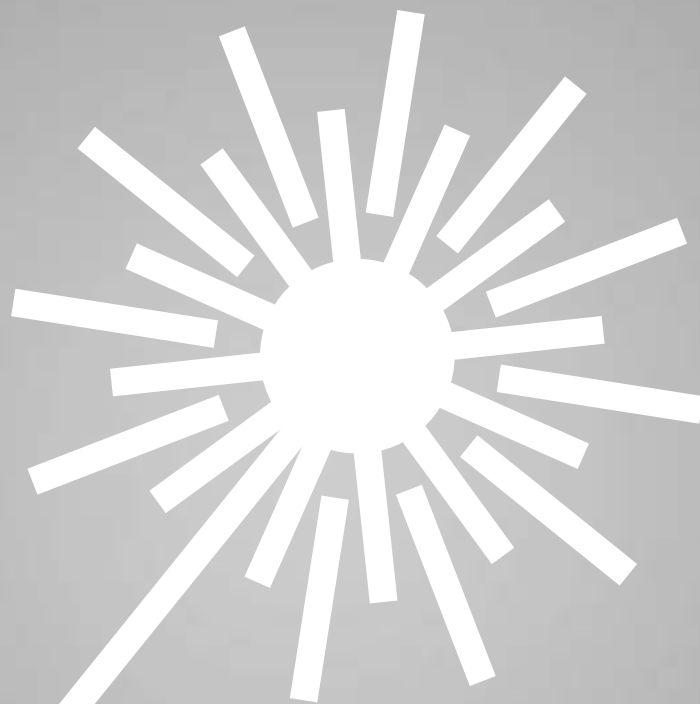

MCO plus Laser: Handstücke und Ansätze

MCO plus Laser: Handpieces and Attachments

Láser MCO plus: Mangos y acoplamientos

Laser MCO plus: Pièces main et embouts adaptables

Laser MCO plus: Manipoli e accessori



76-100-05-04

Fokussierhandstück 50 mm, komplett (für Dermatologie und ästhetische Chirurgie)
Focusing handpiece, 50 mm, complete (for dermatology and aesthetic surgery)
Mango de enfoque de 50 mm, completo (para dermatología y cirugía estética)
Pièce à main de focalisation 50 mm, complète (pour la dermatologie et la chirurgie esthétique)
Dispositivo manuale di focalizzazione 50 mm, completo (per dermatologia e chirurgia estetica)



76-100-06-04



76-500-50-04*

Scanner-Handstück, 127 mm, komplett (für Dermatologie und ästhetische Chirurgie)
Scanner handpiece, 127 mm, complete (for dermatology and aesthetic surgery)
Mango de escáner de 127 mm, completo (para dermatología y cirugía estética)
Pièce à main de scanner, 127 mm, complète (pour la dermatologie et la chirurgie esthétique)
Manipolo per scanner, 127 mm, completo (per dermatologia e chirurgia estetica)



76-500-51-04



76-500-60-04

Scanner-Handstück, 200 mm, komplett (für Dermatologie und ästhetische Chirurgie)
Scanner handpiece, 200 mm, complete (for dermatology and aesthetic surgery)
Mango de escáner de 200 mm, completo (para dermatología y cirugía estética)
Pièce à main de scanner, 200 mm, complète (pour la dermatologie et la chirurgie esthétique)
Manipolo per scanner, 200 mm, completo (per dermatologia e chirurgia estetica)



76-500-61-04



76-500-31-04*

Scannerbox „SoftScan plus R“ (ohne Handstück)
“SoftScan plus R” scanner box (w/o handpiece)
Caja de escáner “SoftScan plus R” (sin mango)
Boîtier de scanner « SoftScan plus R » (sans pièce à main)
Scanner "SoftScan plus R" (senza manipolo)

* Bei Laser mit Scanner inklusive
Included in Laser package
Incluido en el láser con escáner
Compris avec le laser fourni avec scanner
Laser con scanner incluso

MCO plus Laser: Handstücke und Ansätze

MCO plus Laser: Handpieces and Attachments

Láser MCO plus: Mangos y acoplamientos

Laser MCO plus: Pièces main et embouts adaptables

Laser MCO plus: Manipoli e accessori

Laserchirurgie

Laser Surgery

Chirurgía láser

Chirurgie laser

Chirurgia laser

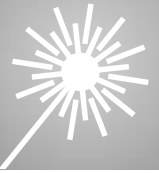

76-501-08-04 *

Handstück softFrac
Handpiece softFrac
Mango softFrac
Pièce à main softFrac
Manipolo softFrac



bis / up to / hasta / jusqu'à / fino a
0.2 mm



0.8 mm
Max. Figurgröße 10 x 10 mm
Max. figure size 10 x 10 mm
Tamaño máx. de la figura 10 x 10 mm
Taille de la figure max. 10 x 10 mm
Max. dimensioni figura 10 x 10 mm



76-502-01-04 *

Handstück powerFrac
Handpiece powerFrac
Mango powerFrac
Pièce à main powerFrac
Manipolo powerFrac



bis / up to / hasta / jusqu'à / fino a
0.2 mm



0.15 mm
Max. Figurgröße 5 x 5 mm
Max. figure size 5 x 5 mm
Tamaño máx. de la figura 5 x 5 mm
Taille de la figure max. 5 x 5 mm
Max. dimensioni figura 5 x 5 mm

76-500-49-04

softFrac Upgrade

Upgrade für bestehende MCOplus-Laser bis einschließlich Baujahr 2012 mit Scanner

Upgrade for existing MCOplus lasers until and including production date 2012 with scanner

Actualización para láseres MCOplus existentes hasta el año de fabricación 2012 inclusive, con escáner

Mise à niveau de lasers MCOplus existants jusqu'à l'année de construction 2012 avec scanner

Upgrade laser MCOplus esistenti fino ad anno di fabbricazione 2012 incluso, con scanner

* nur für MCOplus-Laser ab Baujahr 2013 und Softwarestand 3.5. Für bestehende MCOplus-Laser bis einschließlich Baujahr 2012 mit Scanner muss ein skinFrac Upgrade (Art.Nr. 76-500-49-04 Umrüstsatz ohne Scanner inklusive Handstücke softFrac und powerFrac) bestellt werden.

only for MCOplus lasers from 2013 onwards and software version 3.5. A skinFrac upgrade (Art.No. 76-500-49-04 conversion kit without scanner including softFrac and powerFrac handpieces) must be ordered for existing MCOplus lasers up to and including 2012 with scanner.

solo para láseres MCOplus a partir del año de fabricación 2013 y versión de software 3.5. Para los láseres MCOplus existentes hasta el año de fabricación 2012 inclusive y con escáner, debe solicitarse una actualización skinFrac (n.º de art. 76-500-49-04, kit de conversión sin escáner, inclusive piezas de mano softFrac y powerFrac).

uniquement pour laser MCOplus à partir de 2013 et de la version logicielle 3.5. Une mise à niveau skinFrac (réf. 76-500-49-04 Kit de conversion sans scanner avec pièces à main softFrac et powerFrac) doit être commandée pour les lasers MCOplus existants jusqu'à l'année de construction 2012 avec scanner.

solo per laser MCOplus a partire dall'anno di fabbricazione 2013 e versione software 3.5. Per i laser MCOplus esistenti fino ad anno di fabbricazione 2012 incluso, con scanner, occorre ordinare un upgrade skinFrac (art. n. 76-500-49-04 set di conversione senza scanner, completo di manipoli softFrac e powerFrac).



79-100-57-04

CO₂ Laserschutzbrille
CO₂ laser protective goggles
CO₂ Gafas de protección contra radiación láser
CO₂ Laser Laserschutzbrille
Lunettes de protection laser CO₂

MCO plus Laser: Handstücke und Ansätze

MCO plus Laser: Handpieces and Attachments

Láser MCO plus: Mangos y acoplamientos

Laser MCO plus: Pièces main et embouts adaptables

Laser MCO plus: Manipoli e accessori



76-800-00-04

FlexWave-Hohlkörper, flexible Faser für CO2-Laser
FlexWave hollow core, flexible fiber for CO2 laser
Fibra hueca flexible FlexWave para láser de CO2
Fibre creuse flexible FlexWave, pour laser au CO2
FlexWave fibra cava flessibile per laser CO2



76-810-00-04

Kupplungsadapter für MCOplus-Serie CO2-Laser
mit Führungsarm für unummantelte Faser
Coupling adapter for MCOplus series CO2 laser
includes guide arm for bare fiber

Adaptador de acoplamiento para la serie MCOplus,
el láser de CO2 incluye un brazo

Adaptateur de couplage pour la série MCOplus,
le laser au CO2 comprend le bras de guidage pour fibre nue

Adattatore di accoppiamento per serie MCOplus,
il laser CO2 include il braccio guida per fibra nuda



79-311-00-04

Faserhalter-Handgriff FlexPen 2.0
Fiber holder handle FlexPen 2.0
Mango para portafibras FlexPen 2.0
Poignée de porte-fibre FlexPen 2.0
Impugnatura supporto per fibre FlexPen 2.0



79-311-03-04

Tuohy-Borst-Adapter (VE=25 Stück, steril, single use)
Tuohy-Borst adapter (pack of 25, sterile, single use)
Adaptador Tuohy-Borst (unidad de embalaje = 25 unidades,
estériles, desechables)
Adaptateur Tuohy-Borst (UV=25 unités, stérile, à usage unique)
Adattatore Tuohy-Borst (UV=25 pezzi, sterile, monouso)



79-311-02-04

Ansatzspitze 7 cm mit Absaugung
(2-teilig: Absaugrohr und innenliegendes Faserführungsrohr)
7-cm attachment tip with suction
(2-piece: suction tube and internal fiber guide tube)
Punta de acoplamiento de 7 cm con aspiración
(2 piezas: tubo de aspiración y tubo de guía interior para la fibra)
Embout 7 cm avec aspiration (2 éléments: tube d'aspiration
et tube intérieur de guidage de fibre)
Punta 7 cm con aspiratore
(2 componenti: tubo di aspirazione e tubo guida-fibra interno)



79-311-10-04

Ansatzspitze 10 cm (inkl. Biegedorn)
10-cm attachment tip (incl. bending mandrel)
Punta de acoplamiento de 10 cm (con mandril)
Embout 10 cm (avec mandrin de flexion)
Punta 10 cm (incl. mandrino)

MCO plus Laser

MCO plus Laser
Láser MCO plu
Laser MCO plus
Laser MCO plus

Laserchirurgie

Laser Surgery
Cirugía láser
Chirurgie laser
Chirurgia laser



77-025-11-04*

MCO 25plus mit Scanner, CO₂ laser, 25 W, Superpuls,
Standard-Fokussierhandstück 127 mm,
mit integriertem Scanner "Soft Scan plus" und "SkinFrac"-Modus

MCO 25plus with scanner, CO₂ laser, 25 W, Superpuls,
127-mm standard focusing handpiece, 127-mm
with integrated scanner "Soft Scan plus" and "SkinFrac"-Mode

MCO 25plus con escáner, CO₂ laser, 25 W, Superpuls,
Mango de enfoque de 127 mm,
con escáner integrado modo "Soft Scan plus" y "SkinFrac"

MCO 25plus avec scanner, CO₂ laser, 25 W, Superpuls,
pièce à main de focalisation standard 127 mm,
avec scanner intégré mode "Soft Scan plus" et "SkinFrac"

MCO 25plus con scanner, CO₂ laser, 25 W, Superpuls,
dispositivo manuale di focalizzazione con scanner 127 mm,
con scanner integrato modo "Soft Scan plus" e "SkinFrac"

* nur für MCOplus-Laser ab Baujahr 2013 und Softwarestand 3.5. Für bestehende MCOplus-Laser bis einschließlich Baujahr 2012 mit Scanner muss ein skinFrac Upgrade (Art.Nr. 76-500-49-04 Umrüstsatz ohne Scanner inklusive Handstücke softFrac und powerFrac) bestellt werden.
only for MCOplus lasers from 2013 onwards and software version 3.5. A skinFrac upgrade (Art.No. 76-500-49-04 conversion kit without scanner including softFrac and powerFrac handpieces) must be ordered for existing MCOplus lasers up to and including 2012 with scanner.

solo para láseres MCOplus a partir del año de fabricación 2013 y versión de software 3.5. Para los láseres MCOplus existentes hasta el año de fabricación 2012 inclusive y con escáner, debe solicitarse una actualización skinFrac (n.º de art. 76-500-49-04, kit de conversión sin escáner, inclusive piezas de mano softFrac y powerFrac).

uniquement pour laser MCOplus à partir de 2013 et de la version logicielle 3.5. Une mise à niveau skinFrac (réf. 76-500-49-04 Kit de conversion sans scanner avec pièces à main softFrac et powerFrac) doit être commandée pour les lasers MCOplus existants jusqu'à l'année de construction 2012 avec scanner.

solo per laser MCOplus a partire dall'anno di fabbricazione 2013 e versione software 3.5. Per i laser MCOplus esistenti fino ad anno di fabbricazione 2012 incluso, con scanner, occorre ordinare un upgrade skinFrac (art. n. 76-500-49-04 set di conversione senza scanner, completo di manipoli softFrac e powerFrac).

HF-Chirurgie
HF Surgery
Cirugía AF
Chirurgie HF
Chirurgia AF

80

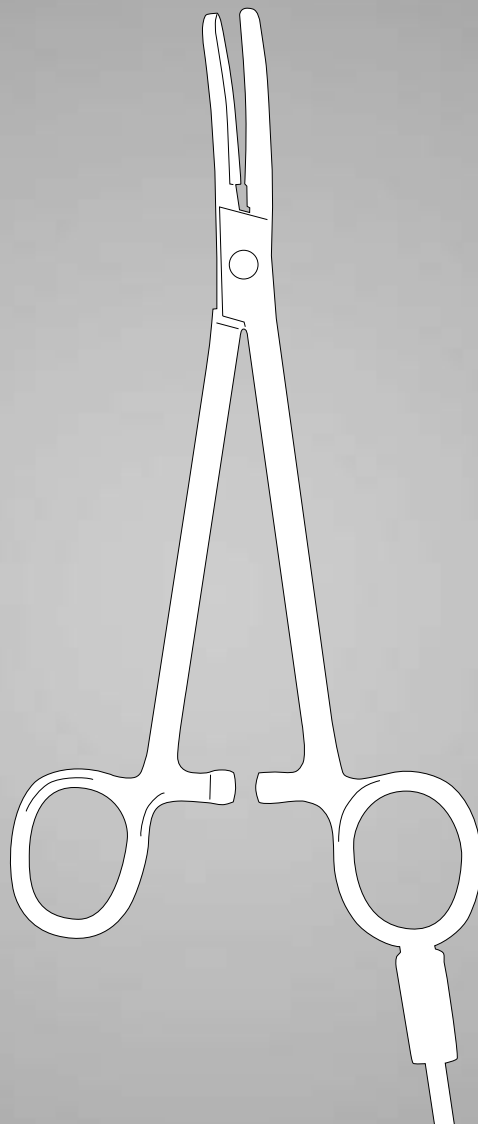

Elektrochirurgische Geräte

Electrosurgical units

Aparatos electroquirúrgicos

Bistouris électrochirurgicaux

Apparecchi elettrochirurgici

maXium®



80-042-00-04

maXium® **m**
(100-240 V)

80-042-02-04

maXium® **i**
(100-240 V)

80-042-04-04

maXium® **e**
(100-240 V)

maXium® smart C



80-043-00-04

maXium® smart C **m**
(100-240 V)

80-043-01-04

maXium® smart C **i**
(100-240 V)

80-043-02-04

maXium® smart C **e**
(100-240 V)

80-094-00-04

maXium® smart C
Option SWAP-Mode
Option SWAP mode
Opción modo SWAP
Option mode SWAP
Opzione modo SWAP

80-094-01-04

maXium® smart C
Option Duo-Prep, Duo-Spray
Option Duo-Prep, Duo-Spray
Opción Duo-Prep, Duo-Spray
Option Duo-Prep, Duo-Spray
Opzione Duo-Prep, Duo-Spray

80-094-02-04

maXium® smart C
Option Neptun
Option Neptun
Opción Neptun
Option Neptun
Opzione Neptun



reddot award 2016
winner



Focus Open 2016
Special Mention

Elektrochirurgische Geräte

Electrosurgical units
Aparatos electroquirúrgicos
Bistouris électrochirurgicaux
Apparecchi elettrochirurgici

HF-Chirurgie

HF Surgery
Cirugía AF
Chirurgie HF
Chirurgia AF



ME 102



80-010-02-04
(220-240 V)

80-010-02-12
(100-127 V)

miniCutter



80-008-03-04
(100-240 V)

NervScout



80-065-00-04

Nervstimulator
Nerve Stimulator
Estimulador de nervios
Neurostimulateur
Neurostimolatore

Ø 4 mm

1/4



80-217-03-04 *max. 5500 V_p*

KLS Martin

NeuroPen-Handgriff mit 3 Tasten, 4 m Kabel
NeuroPen handle with 3 buttons, 4-m cable
Mango NeuroPen con 3 conmutadores, 4 m de cable
Manche NeuroPen à 3 touches, câble de 4 m
Impugnatura NeuroPen con 3 tasti, cavo da 4 m

1/2



80-565-01-04 = Ø 1 mm

80-565-02-04 = Ø 2 mm

80-565-03-04 = Ø 3 mm

Nervstimulator Kugelelektrode
Nerve stimulator ball electrode
Electrodo de bola estimulador de nervios
Electrode boule neurostimulateur
Elettrodo a sfera neurostimolatore

Monopolare Elektroden-Handgriffe

Monopolar electrode handles

Mangos porta-electrodos monopolares

Manches porte-électrode monopolaires

Manici portaelettrodi monopolari

Passend für Aktivelektroden mit \varnothing 4 mm (siehe Seite xx)

For active electrodes \varnothing 4 mm (see page xx)

Para electrodos activos con \varnothing 4 mm (véase página xx)

Pour électrodes actives \varnothing 4 mm (voir page xx)

Per elettrodi attivi con \varnothing 4 mm (vedi a pag. xx)

\varnothing 4 mm



80-210-13-04 *max. 6300 V_p*

KLS Martin/Erbe intern. Version/Valleylab

Elektroden-Handgriff mit zwei Tasten, 3-Pin-Stecker und fest angeschlossenem 4 m Kabel

Electrode handle with two pushbuttons, 3-pin plug and permanent cord of 4 m

Mango porta-electrodos con dos teclas, clavija de 3 patillas y cable de conexión fija de 4 m

Manche porte-électrode avec interrupteur digital double, fiche à 3 broches et câble de raccordement fixe de 4 m

Manico portaelettrodi con due tasti, spina a 3-spire e cavo di connessione fisso da 4 m

\varnothing 4 mm



80-217-13-04 *max. 6300 V_p*

KLS Martin

Elektroden-Handgriff mit zwei Tasten, großem Koax-Stecker und fest angeschlossenem 4 m Kabel

Electrode handle with two pushbuttons, large coax plug and permanent cord of 4 m

Mango porta-electrodos con dos teclas, clavija coaxial grande y cable de conexión fija de 4 m

Manche porte-électrode avec interrupteur digital double, grande fiche coax et câble de raccordement fixe de 4 m

Manico portaelettrodi con due tasti, spina coassiale grande e cavo di connessione fisso da 4 m

\varnothing 4 mm



80-220-02-04 *max. 6300 V_p*

KLS Martin

Elektroden-Handgriff ohne Tasten, großem Koax-Stecker und fest angeschlossenem 4 m Kabel

Electrode handle without pushbuttons, large coax plug and permanent cord of 4 m

Mango porta-electrodos sin teclas, clavija coaxial grande y cable de conexión fija de 4 m

Manche porte-électrode sans interrupteur, grande fiche coax et câble de raccordement fixe de 4 m

Manico portaelettrodi senza tasti, spina coassiale grande e cavo di connessione fisso da 4 m

Monopolare Elektroden-Handgriffe

Monopolar electrode handles
Mangos porta-electrodos monopolares
Manches porte-électrode monopolaires
Manici portaelettrodi monopolari

HF-Chirurgie

HF Surgery
Cirugía AF
Chirurgie HF
Chirurgia AF



Passend für Aktivelektroden mit Ø 2,4 mm und Ø 1,6 mm (siehe Seite xx)

For active electrodes Ø 2.4 mm and Ø 1.6 mm (see page xx)

Para electrodos activos con Ø 2,4 mm y Ø 1,6 mm (véase página xx)

Pour électrodes actives Ø 2,4 mm et Ø 1,6 mm (voir page xx)

Per elettrodi attivi con Ø 2,4 mm y Ø 1,6 mm (vedi a pag. xx)

Ø 2,4 mm



80-210-21-04 *max. 6300 V_p*

KLS Martin/Erbe intern. Version/Valleylab

Elektroden-Handgriff mit zwei Tasten, 3-Pin-Stecker und fest angeschlossenen 4 m Kabel

Electrode handle with two pushbuttons, 3-pin plug and permanent cord of 4 m

Mango porta-electrodos con dos teclas, clavija de 3 patillas y cable de conexión fija de 4 m

Manche porte-électrode avec interrupteur digital double, fiche à 3 broches et câble de raccordement fixe de 4 m

Manico portaelettrodi con due tasti, spina a 3-spire e cavo di connessione fisso da 4 m

Ø 1,6 mm



80-214-12-04 *max. 6300 V_p*

KLS Martin

Dental-Elektroden-Handgriff ohne Taste, großem Koax-Stecker und fest angeschlossenen 4 m Kabel

Dental electrode handle without pushbutton, large coax plug and permanent cord of 4 m

Mango porta-electrodos dental sin tecla, clavija coaxial grande y cable de conexión fija de 4 m

Manche porte-électrode dentaire sans interrupteur digital, grande fiche coax et câble de raccordement fixe de 4 m

Manico portaelettrodi dentale senza tasto, spina coassiale grande e cavo di connessione fisso da 4 m

Bipolare Anschlusskabel

Bipolar connection cables

Cables de conexión bipolares

Câbles de raccordement bipolaires

Cavi di connessione bipolari

max. 600 V_p



80-286-30-04

3 m/10 ft.

80-286-50-04

5 m/16 ft.

maXium® „e“-Version/Erbe-Geräte ICC und ACC/VIO
→ bipolare Instrumente

maXium® "e"-version/ICC and ACC/VIO Erbe units
→ bipolar instruments

maXium® versión "e"/aparatos Erbe ICC e ACC/VIO
→ instrumentos bipolares

maXium® version «e»/appareils Erbe ICC et ACC/VIO
→ instruments bipolaires

maXium® versione "e"/apparecchi Erbe ICC e ACC/VIO
→ strumenti bipolari



80-286-40-04

4 m/13 ft.

maXium® „e“-Version/Erbe-Geräte ICC und ACC/VIO
→ bipolare Instrumente

maXium® "e"-version/ICC and ACC/VIO Erbe units
→ bipolar instruments

maXium® versión "e"/aparatos Erbe ICC e ACC/VIO
→ instrumentos bipolares

maXium® version «e»/appareils Erbe ICC et ACC/VIO
→ instruments bipolaires

maXium® versione "e"/apparecchi Erbe ICC e ACC/VIO
→ strumenti bipolari



80-287-33-04

3 m/10 ft.

80-287-53-04 max. 600 V_p

5 m/16 ft.

KLS-Martin-, Berchtold- und Aesculap-Geräte
→ bipolare Instrumente

KLS Martin, Berchtold and Aesculap units
→ bipolar instruments

Aparatos KLS Martin, Berchtold y Aesculap
→ instrumentos bipolares

Câble de raccordement pour instruments bipolaires
→ instruments bipolaires

Apparecchi KLS Martin, Berchtold e Aesculap
→ strumenti bipolari



80-287-72-04

5 m/16 ft.

Codman- und Valleylab-Geräte
→ bipolare Instrumente

Codman and Valleylab units
→ bipolar instruments

aparatos Codman y Valleylab
→ instrumentos bipolares

appareils Codman et Valleylab
→ instruments bipolaires

apparecchi Codman e Valleylab
→ strumenti bipolari

Bipolare Anschlusskabel

Bipolar connection cables
Cables de conexión bipolares
Câbles de raccordement bipolaires
Cavi di connessione bipolari

HF-Chirurgie

HF Surgery
Cirugía AF
Chirurgie HF
Chirurgia AF



1/2

80-287-89-04 80-287-90-04

3 m/10 ft. 5 m/16 ft.

maXium® „i“-Version, ME MB 3 „i“-Version, ME MB 2 „i“-Version/
Valleylab-Geräte → bipolare Instrumente

maXium® „i“-version, ME MB 3 „i“-Version, ME MB 2 „i“-Version/
Valleylab units → bipolare Instrumente

maXium® versión „i“, ME MB 3 versión „i“, ME MB 2 versión „i“/
aparatos Valleylab → bipolare Instrumente

maXium® version «i», ME MB 3 version «i», ME MB 2 version «i»/
appareils Valleylab → bipolare Instrumente

maXium® versione „i“, ME MB 3 versione „i“, ME MB 2 versione „i“/
apparecchi Valleylab → bipolare Instrumente



1/2

80-291-40-04

4 m/13 ft.

KLS Martin-, Berchtold-, Aesculap-Geräte
→ bipolare Instrumente

KLS Martin, Berchtold, Aesculap units
→ bipolare Instrumente

Aparatos KLS Martin, Berchtold, Aesculap
→ bipolare Instrumente

Appareils KLS Martin, Berchtold, Aesculap
→ bipolare Instrumente

Apparecchi KLS Martin, Berchtold, Aesculap
→ bipolare Instrumente



1/2

80-293-40-04

4 m/13 ft.

ME MB 2 „i“-Version/Valleylab-Geräte
→ bipolare Instrumente

ME MB 2 „i“-Version/Valleylab units
→ bipolare Instrumente

ME MB 2 versión „i“/aparatos Valleylab
→ bipolare Instrumente

ME MB 2 version «i»/appareils Valleylab
→ bipolare Instrumente

ME MB 2 versione „i“/apparecchi Valleylab
→ bipolare Instrumente



1/2

80-294-40-04

4 m/13 ft.

KLS Martin

Anschlusskabel für Einmal-Neutralelektroden

Connection cable for disposable neutral electrodes

Cable de conexión para placas neutras
desechables

Câble de raccordement pour électrodes
neutres à usage unique

Cavo di connessione per elettrodi neutri
monouso

Einmal-Neutralelektroden

Disposable neutral electrodes
Placas neutras desechables
Electrodes neutres à usage unique
Elettrodi neutri monouso



Anschlusskabel für Einmal-Neutralelektroden

Connection cable for disposable neutral electrodes

Cable de conexión para placas neutras desechables

Câble de raccordement pour électrodes neutres à usage unique

Cavo di connessione per elettrodi neutri monouso

80-294-44-04

5 m/16 ft.

maXium® „i“-Version,
ME MB 3 „i“-Version,
ME MB 2 „i“-Version, Valleylab



80-344-09-04

PCS-DuoSafe-Einmal-Neutralelektrode für Erwachsene und Kinder, geteilte Kontaktfläche 107 cm², ohne Anschlusskabel, 50 Stück/VE

PCS DuoSafe disposable neutral electrode for adults and children, split contact surface 107 cm², without connection cable, 50/pack

Placa neutra desechable tipo PCS DuoSafe con dos partes separadas 107 cm² para adultos y niños, sin cable de conexión, 50 piezas/unidad

Electrode neutre à usage unique type PCS DuoSafe avec deux surfaces de contact séparées 107 cm² pour adultes et enfants, sans câble de raccordement, 50 pièces/unité

Elettrodo neutro monouso tipo PCS DuoSafe con due superfici separate 107 cm² per adulti e bambini, senza cavo di connessione, 50 pezzi/unità

Elektroden-Adapter für monopolare Handgriffe

Electrode adapter for monopolar handles
Adaptador de electrodos para mangos monopolares
Adaptateur pour manches monopolaires
Adattatore elettrodo per manipoli monopolari

HF-Chirurgie

HF Surgery
Cirugía AF
Chirurgie HF
Chirurgia AF



Elektrodenfixierung über Schraubkappe

Electrode fixation with screw cap

Fijación de electrodos con tapa roscada

Fixation de l'électrode à l'aide du bouchon à vis

Fissaggio elettrodo tramite tappo a vite



80-460-04-04 max. 3700 V_p

Adapter von Ø 4 mm auf Ø 1,6 mm, z.B. Dental-Elektroden
Adapter from Ø 4 mm to Ø 1.6 mm, e.g. for dental electrodes
Adaptador de Ø 4 mm a Ø 1,6 mm, p.e. para electrodos dentales
Adaptateur de Ø 4 mm à Ø 1,6 mm, p.e. pour électrodes dentaires
Adattatore da Ø 4 mm a Ø 1,6 mm, p.e. per elettrodi dentali



80-531-00-04 max. 3700 V_p

Adapter von Ø 4 mm auf Ø 3/32" = 2,4 mm
Adapter from Ø 4 mm to Ø 3/32" = 2.4 mm
Adaptador de Ø 4 mm a Ø 3/32" = 2,4 mm
Adaptateur de Ø 4 mm à Ø 3/32" = 2,4 mm
Adattatore da Ø 4 mm a Ø 3/32" = 2,4 mm

Elektroden mit Ø 1,6 mm

Electrodes Ø 1.6 mm

Electrodos con Ø 1,6 mm

Electrodes Ø 1,6 mm

Elettrodi Ø 1,6 mm

Ø 1,6 mm



80-461-02-04

Fig. 2

Nadelelektrode, 45° abgewinkelt
Needle electrode, 45° angled
Electrodo de aguja, acodado 45°
Electrode aiguille, coudée en 45°
Elettrodo ad ago, angolo 45°



80-466-01-04

Fig. 1

Nadelelektrode, gerade
Needle electrode, straight
Electrodo de aguja, recto
Electrode aiguille, droite
Elettrodo ad ago, retto

Monopolare Elektroden

Monopolar electrodes
Electrodos monopolares
Electrodes monopolaires
Elettrodi monopolari

KLS-Martin-SYN-Elektroden mit farbkodierter Kunststoffisolation

KLS Martin SYN electrodes with color-coded plastic insulation

SYN electrodos KLS Martin con aislamiento de plástico en color codificado

SYN électrodes KLS Martin avec isolation en matière plastique avec code couleur

SYN elettrodi KLS Martin con isolamento in materiale plastico con codice colore

Aktivelektroden mit Ø 4 mm

Active electrodes Ø 4 mm

Electrodos activos con Ø 4 mm

Electrodes actives Ø 4 mm

Elettrodi attivi Ø 4 mm

Ø 4 mm  max. 4000 V_p



80-510-06-04

Lanzettelektrode, gerade,	VE = 5 Stück
Lancet electrode, straight,	SU = 5/pack
Electrodo de lanceta, recto,	UV = 5 piezas
Electrode lancette, droite,	UC = 5 unités
Elettrodo a lancetta, retto,	UV = 5 pezzi



80-520-06-04

Nadelelektrode,	VE = 5 Stück
Needle electrode,	SU = 5/pack
Electrodo de aguja,	UV = 5 piezas
Electrode aiguille,	UC = 5 unités
Elettrodo ad ago,	UV = 5 pezzi



80-521-02-04

Nadelelektrode,	VE = 5 Stück
Needle electrode,	SU = 5/pack
Electrodo de aguja,	UV = 5 piezas
Electrode aiguille,	UC = 5 unités
Elettrodo ad ago,	UV = 5 pezzi



80-542-06-04

Drahtschlingenelektrode, Wolfram
Wire loop electrode, tungsten
Electrodo de asa de alambre, tungsteno
Electrode anse en fil, en tungstène
Elettrodo ad ansa di filo, tungsteno

Monopolare Elektroden

Monopolar electrodes
Electrodos monopolares
Electrodes monopolaires
Elettrodi monopolari

HF-Chirurgie

HF Surgery
Cirugía AF
Chirurgie HF
Chirurgia AF

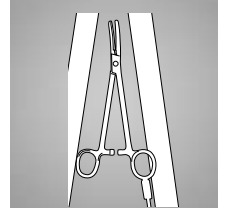

Aktivelektroden mit Ø 2,4 mm
Active electrodes Ø 2.4 mm
Electrodos activos con Ø 2,4 mm
Electrodes actives Ø 2,4 mm
Elettrodi attivi Ø 2,4 mm

Ø 2,4 mm 



80-520-09-04 **max. 2900 V_p**

Nadelektrode für die Mikrodissektion, Wolframspitze,
VE = 5 Stück, wiederverwendbar
Needle electrode for dissection, tungsten tip,
5 items/pack, reusable
Electrodo de aguja para la disección, punta de tungsteno,
UE = 5 unidades, reutilizable
Electrode aiguille pour dissection, pointe en tungstène,
UE = 5 pièces, réutilisable
Elettrodo ad ago per dissezione, punta in tungsteno,
UV = 5 unità, riutilizzabile

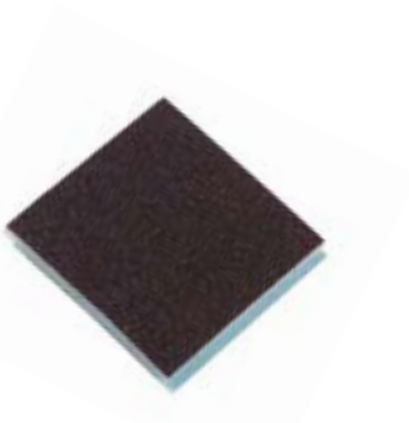

80-505-00-04 **STERILE IEO**

Reinigungspad für Elektroden, steril verpackt,
Cleaning pad for electrodes, sterile packed,
Almohadilla de limpieza para electrodos, embalado estéril,
Tampon de nettoyage pour électrodes, emballage stérile,
Tampone di pulizia per elettrodi, imballaggio sterile,

VE = 100 Stück
SU = 100 /pack
UV = 100 piezas
UC = 100 unités
UV = 100 pezzi

Bipolare Scheren

Bipolar scissors
Tijeras bipolares
Ciseaux bipolaires
Forbici bipolari

marCut®



80-287-33-04 80-287-53-04
3 m/10 ft. 5 m/16 ft.

KLS-Martin- und Berchtold-Geräte
→ bipolare Instrumente

KLS Martin and Berchtold units
→ bipolar instruments

aparatos KLS Martin y Berchtold
→ instrumentos bipolares

appareils KLS Martin et Berchtold
→ instruments bipolaires

apparecchi KLS Martin e Berchtold
→ strumenti bipolari

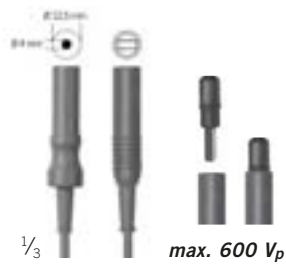

80-286-30-04 80-286-50-04
3 m/10 ft. 5 m/16 ft.

maXium® „e“-Version/Erbe-Geräte ICC und ACC/VIO
→ bipolare Instrumente

maXium® "e"-Version/ICC and ACC/VIO Erbe units
→ bipolar instruments

maXium® versión "e"/aparatos Erbe ICC e ACC/VIO
→ instrumentos bipolares

maXium® version «e»/appareils Erbe ICC et ACC/VIO
→ instruments bipolaires

maXium® versione "e"/apparecchi Erbe ICC e ACC/VIO
→ strumenti bipolari



80-287-89-04 80-287-90-04
3 m/10 ft. 5 m/16 ft.

maXium® „i“-Version, ME MB 3 „i“-Version, ME MB 2
„i“-Version/Valleylab-Geräte → bipolare Instrumente

maXium® "i"/ME MB 3 "i"-Version, ME MB 2
"i"-Version/Valleylab units → bipolar instruments

maXium® versión "i"/ME MB 3 versión "i"/ME MB 2
versión "i"/aparatos Valleylab → instrumentos bipolares

maXium® version «i», ME MB 3 version «i», ME MB 2
version «i»/appareils Valleylab → instruments bipolaires

maXium® versione "i", ME MB 3 versione "i"/ME MB 2
versione "i"/apparecchi Valleylab → strumenti bipolari

Super Slim Line

Superschlanke Version
Super slim model
Versión super delgada
Version super mince
Versione extra snella

max. 300 V_p



80-572-13-04
marCut® SSL
13 cm / 5 1/8"

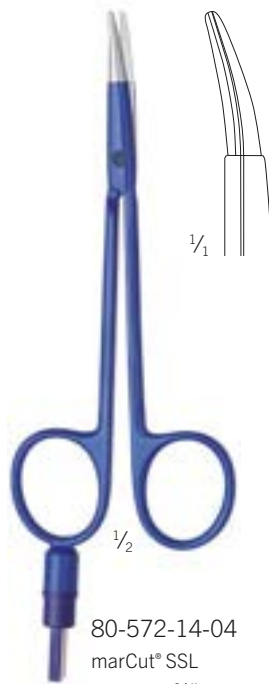

80-572-14-04
marCut® SSL
14 cm / 5 5/8"



80-572-17-04
marCut® SSL
17 cm / 6 5/8"

Bipolare Klemmen für die Gefäßversiegelung

Bipolar forceps for vessel sealing

Pinzas bipolares para el sellado vascular

Pinces bipolaires pour le clamage vasculaire

Pinze bipolari per clampaggio vascolare

HF-Chirurgie

HF Surgery

Cirurgía AF

Chirurgie HF

Chirurgia AF

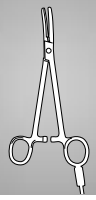

marClamp® IQ



maXium®

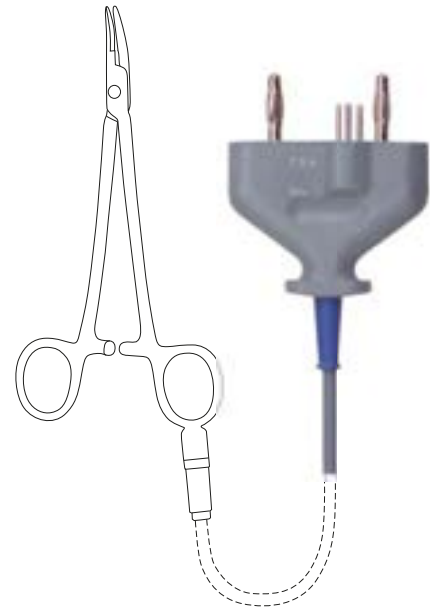

marClamp®, gebogene Version
marClamp®, curved version
marClamp®, versión curva
marClamp®, version courbe
marClamp®, versione curva

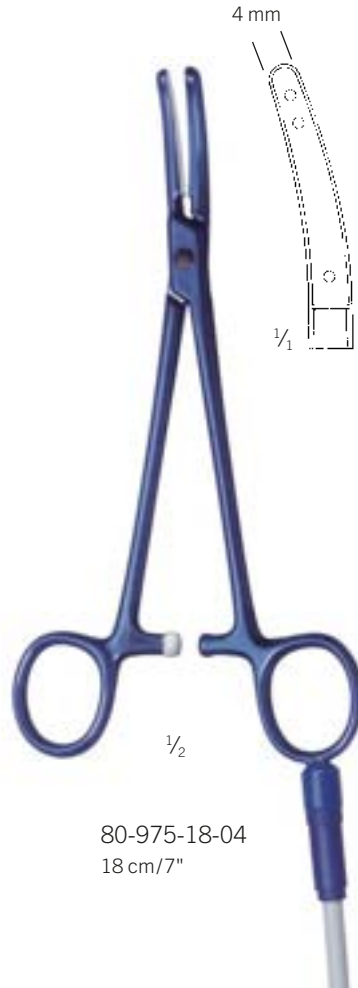

Kombi-Instrument für die offenchirurgische Gefäßversiegelung

Combination instrument for open surgical vessel sealing

Instrumento combinado para el sellado vascular en cirugía abierta

Instrument combiné de scellement de vaisseaux sanguins pour la chirurgie ouverte

Strumento combinato per la sigillatura vascolare nella chirurgia a cielo aperto

marClamp® Cut IQ



✓ Präparieren	Dissect	Diseccionar	Disséquer	Sezionare
✓ Versiegeln	Seal	Sellar	Clamper	Sigillare
✓ Trennen	Cut	Cortar	Couper	Separare
✓ Plug & Play (mit integriertem Schalter für maXium® Hardware 06, Software ab V 3.412)	Plug & Play (with integrated switch for maXium® hardware 06, software from V 3.412)	Plug & Play (con interruptor integrado para hardware maXium® 06, software a partir de V 3.412)	Plug & Play (avec interrupteur intégré pour hardware maXium® 06, logiciel à partir de V 3.412)	Plug & Play (con interruttore integrato per hardware maXium® 06, software a partire di V 3.412)
✓ Kein Instrumentenwechsel	No need to exchange instruments	No es necesario cambiar de instrumento	Il n'est pas nécessaire de changer d'instruments	Senza necessità di cambiare strumento
✓ Wiederverwendbar	Reusable	Reutilizable	Réutilisable	Riutilizzabile

	marClamp®-CUT-IQ-System Instrument, komplett*, ohne Klinsen	marClamp® Cut IQ System Instrument, complet*, without blades	Sistema marClamp® Cut IQ Instrumento, completo*, sin cuchillas
80-632-18-04	marClamp® Cut IQ, 18 cm	marClamp® Cut IQ, 18 cm	marClamp® Cut IQ, 18 cm

	Komponenten	Components	Componentes
80-632-00-04	Klinge für marClamp® Cut IQ, steril, VE=10	Blade for marClamp® Cut IQ, sterile, pack of 10	Cuchilla para marClamp® Cut IQ, estéril, UE=10
80-630-58-04	Reinigungswerkzeug	Cleaning tool	Herramienta de limpieza
80-632-01-04	Set Reinigungsbürsten, 3 Stück	Set of cleaning brushes, 3 pcs.	Juego de cepillos de limpieza, 3 unidades

* inkl. 80-630-58-04, 80-632-01-04

* incl. 80-630-58-04, 80-632-01-04

* incl. 80-630-58-04, 80-632-01-04

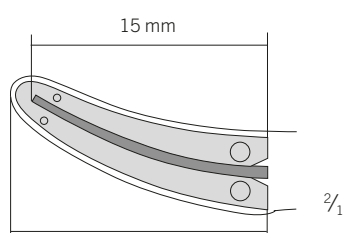
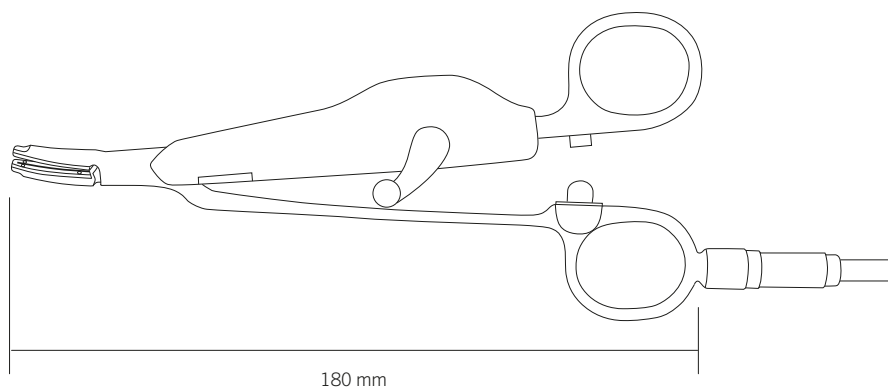



Integrierter Schalter zur Handaktivierung
 Integrated switch for manual activation
 Interruptor integrado para la activación manual
 Interrupteur intégré pour l'activation manuelle
 Interruttore integrato per l'attivazione manuale

maXium®



	Système marClamp® Cut IQ Instrument, complet*, sans lames	Sistema marClamp® Cut IQ Strumento, completo*, senza lame
80-632-18-04	marClamp® Cut IQ, 18 cm	marClamp® Cut IQ, 18 cm

	Composants	Componenti
80-632-00-04	Lame pour instrument marClamp® Cut IQ, stérile, UC=10	Lama per marClamp® Cut IQ, sterile, confezione=10 unità
80-630-58-04	Outil de nettoyage	Strumento di pulizia
80-632-01-04	Jeu de brosses de nettoyage, 3 unités	Set di spazzolini di pulizia, 3 pezzi

* incl. 80-630-58-04, 80-632-01-04

* incl. 80-630-58-04, 80-632-01-04

„IQ“

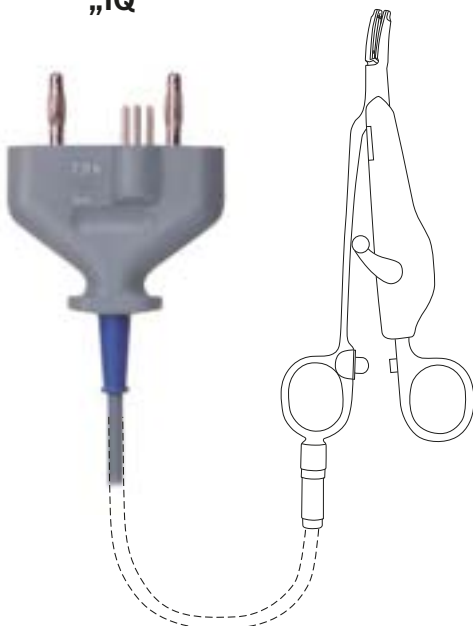

Weitere Informationen entnehmen Sie bitte der separaten Broschüre.

For further information please refer to our separate product brochure.

Encontrará informaciones adicionales en el folleto individual.

Vous trouverez des informations supplémentaires dans la brochure.

Per ulteriori informazioni vedasi il prospetto separato.

Bipolare Pinzetten, nonStick red

Bipolar forceps, nonStick red
Pinzas bipolares, nonStick red
Pincas bipolares, nonStick red
Pinze bipolari, nonStick red

nonStick red

max. 500 V_p

revolutionary
ergonomic
design



1/1



1/1

Bipolare Pinzetten, gerade
Bipolar forceps, straight
Pinzas bipolares, rectas
Pincas bipolares, droites
Pinze bipolari, diritte

marSIGHT

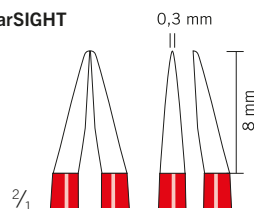

marSIGHT

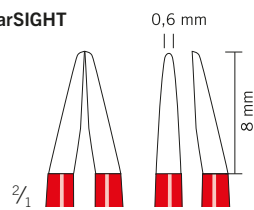

Standard

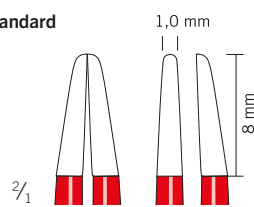

Standard

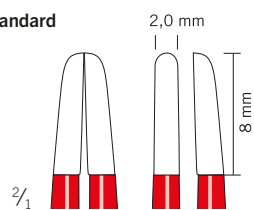

Spitzenbreite Tip width Ancho de la punta Largeur des pointes Larghezza delle punte	Länge Length Longitud Longueur Lunghezza	Artikel-Nr. Item No. N.º referencia Référence Codice articolo
---	--	---

spitz/pointed/puntiaguda/pointue/acuta

0,3 mm	12 cm/4 3/4"	80-982-12-04
0,3 mm	17 cm/6 1/4"	80-982-17-04
0,3 mm	20 cm/8"	80-982-20-04
0,3 mm	23 cm/9"	80-982-23-04

stumpf/blunt/roma/mousse/smuusa

0,6 mm	12 cm/4 3/4"	80-984-12-04
0,6 mm	17 cm/6 1/4"	80-984-17-04
0,6 mm	20 cm/8"	80-984-20-04

stumpf/blunt/roma/mousse/smuusa

1,0 mm	12 cm/4 3/4"	80-986-12-04
1,0 mm	17 cm/6 1/4"	80-986-17-04
1,0 mm	20 cm/8"	80-986-20-04
1,0 mm	23 cm/9"	80-986-23-04

stumpf/blunt/roma/mousse/smuusa

2,0 mm	17 cm/6 1/4"	80-988-17-04
2,0 mm	20 cm/8"	80-988-20-04
2,0 mm	23 cm/9"	80-988-23-04
2,0 mm	30 cm/11 3/4"	80-988-30-04

80-982-12-04
12 cm/4 3/4"
spitz, 0,3 mm
pointed, 0,3 mm
puntiaguda, 0,3 mm
pointue, 0,3 mm
acuta, 0,3 mm

Beispielabbildung
Example illustration
Ilustración a modo de ejemplo
Illustration à titre d'exemple
Figura di esempio

Bipolare Pinzetten, nonStick red

Bipolar forceps, nonStick red
Pinzas bipolares, nonStick red
Pincas bipolares, nonStick red
Pinces bipolaires, nonStick red
Pinze bipolari, nonStick red

HF-Chirurgie

HF Surgery
Cirugía AF
Chirurgie HF
Chirurgia AF



max. 500 V_p

revolutionary
ergonomic
design



Bipolare Pinzetten, gewinkelt
Bipolar forceps, angled
Pinzas bipolares, acodadas
Pincas bipolares, coudées
Pinze bipolari, piegate

	Spitzenbreite Tip width Ancho de la punta Largeur des pointes Larghezza delle punte	Länge Length Longitud Longueur Lunghezza	Artikel-Nr. Item No. N.º referencia Référence Codice articolo	
Standard	0,3 mm 8 mm 2/1	spitz/pointed/puntiaguda/pointue/acuta		
		0,3 mm	12 cm/4 3/4"	80-983-12-04
		0,3 mm	17 cm/6 1/4"	80-983-17-04
Standard	0,6 mm 8 mm 2/1	stumpf/blunt/roma/mousse/smuusa		
		0,6 mm	12 cm/4 3/4"	80-985-12-04
		0,6 mm	17 cm/6 1/4"	80-985-17-04
		0,6 mm	20 cm/8"	80-985-20-04
Standard	1,0 mm 8 mm 2/1	stumpf/blunt/roma/mousse/smuusa		
		1,0 mm	12 cm/4 3/4"	80-987-12-04
		1,0 mm	17 cm/6 1/4"	80-987-17-04
		1,0 mm	20 cm/8"	80-987-20-04
		1,0 mm	23 cm/9"	80-987-23-04
Standard	2,0 mm 8 mm 2/1	stumpf/blunt/roma/mousse/smuusa		
		2,0 mm	17 cm/6 1/4"	80-989-17-04
		2,0 mm	20 cm/8"	80-989-20-04
		2,0 mm	23 cm/9"	80-989-23-04
		2,0 mm	25 cm/9 3/4"	80-989-25-04
		2,0 mm	28 cm/11"	80-989-28-04
		2,0 mm	30 cm/11 3/4"	80-989-30-04

80-983-12-04
12 cm/4 3/4"
spitz, 0,3 mm
pointed, 0,3 mm
puntiaguda, 0,3 mm
pointue, 0,3 mm
acuta, 0,3 mm

Beispielabbildung
Example illustration
Ilustración a modo de ejemplo
Illustration à titre d'exemple
Figura di esempio

KLS Martin **nonStick** red –

die bipolaren Pinzetten von KLS Martin mit ANTIHAFTEFFEKT und revolutionärer Ergonomie
the bipolar forceps from KLS Martin – with nonStick effect and a revolutionary ergonomic design
las pinzas bipolares de KLS Martin con efecto ANTIADHERENTE y ergonomía revolucionaria
les pincas bipolaires de KLS Martin à effet ANTI-ADHÉSIF et ergonomie révolutionnaire
le pinze bipolari di KLS Martin con effetto ANTIADERENTE ed ergonomía rivoluzionaria

Bipolare Pinzetten, nonStick red

Bipolar forceps, nonStick red
Pinzas bipolares, nonStick red
Pincers bipolaires, nonStick red
Pinze bipolari, nonStick red

nonStick red

max. 500 V_p



1/1

Beispielabbildung
Example illustration
Ilustración a modo de ejemplo
Illustration à titre d'exemple
Figura di esempio

revolutionary
ergonomic
design

Bipolare Pinzetten, bajonettförmig
Bipolar forceps, bayonet-shaped
Pinzas bipolares, bayoneta
Pincers bipolaires, à baïonnette
Pinze bipolari, baionetta

	Spitzenbreite Tip width Ancho de la punta Largeur des pointes Larghezza delle punte	Länge Length Longitud Longueur Lunghezza	Artikel-Nr. Item No. N.º referencia Référence Codice articolo
marSIGHT 	spitz/pointed/puntiaguda/pointue/acuta		
	0,3 mm	17 cm/6 1/4"	80-990-17-04
	0,3 mm	20 cm/8"	80-990-20-04
	0,3 mm	23 cm/9"	80-990-23-04
0,3 mm	25 cm/9 3/4"	80-990-25-04	
marSIGHT 	stumpf/blunt/roma/mousse/smussa		
	0,6 mm	17 cm/6 1/4"	80-991-17-04
	0,6 mm	20 cm/8"	80-991-20-04
	0,6 mm	23 cm/9"	80-991-23-04
0,6 mm	25 cm/9 3/4"	80-991-25-04	
Standard 	stumpf/blunt/roma/mousse/smussa		
	1,0 mm	17 cm/6 1/4"	80-992-17-04
	1,0 mm	20 cm/8"	80-992-20-04
	1,0 mm	23 cm/9"	80-992-23-04
1,0 mm	25 cm/9 3/4"	80-992-25-04	
Standard 	stumpf/blunt/roma/mousse/smussa		
	2,0 mm	17 cm/6 1/4"	80-993-17-04
	2,0 mm	20 cm/8"	80-993-20-04
	2,0 mm	23 cm/9"	80-993-23-04
2,0 mm	25 cm/9 3/4"	80-993-25-04	

Bipolare Pinzetten, nonStick red

Bipolar forceps, nonStick red
Pinzas bipolares, nonStick red
Pincas bipolaires, nonStick red
Pinze bipolari, nonStick red

HF-Chirurgie

HF Surgery
Cirugía AF
Chirurgie HF
Chirurgia AF



max. 500 V_p

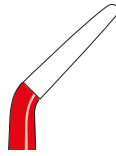

nach oben gewinkelt
upward-bent
acodada hacia arriba
coudée vers le haut
piegata in alto

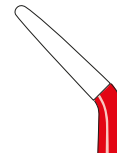

nach unten gewinkelt
downward-bent
acodada hacia abajo
coudée vers le bas
piegata in basso

Bipolare Pinzetten, bajonettförmig, gewinkelt
Bipolar forceps, bayonet-shaped, angled
Pinzas bipolares, bayoneta, acodadas
Pincas bipolaires, à baïonnette, coudées
Pinze bipolari, baionetta, piegate

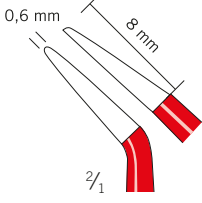
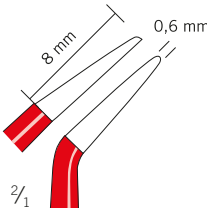
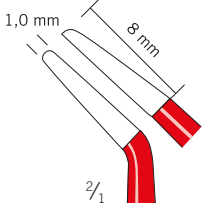
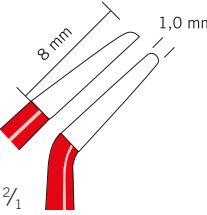
	Spitzenbreite Tip width Ancho de la punta Largeur des pointes Larghezza delle punte	Länge Length Longitud Longueur Lunghezza	Artikel-Nr. Item No. N.º referencia Référence Codice articolo
Standard 	stumpf/blunt/roma/mousse/smussa		
	0,6 mm	23 cm/9"	80-997-23-04
	0,6 mm	25 cm/9 3/4"	80-997-25-04
Standard 	stumpf/blunt/roma/mousse/smussa		
	0,6 mm	23 cm/9"	80-996-23-04
	0,6 mm	25 cm/9 3/4"	80-996-25-04
Standard 	stumpf/blunt/roma/mousse/smussa		
	1,0 mm	20 cm/8"	80-994-20-04
	1,0 mm	23 cm/9"	80-994-23-04
Standard 	stumpf/blunt/roma/mousse/smussa		
	1,0 mm	20 cm/8"	80-995-20-04
	1,0 mm	23 cm/9"	80-995-23-04
	1,0 mm	25 cm/9 3/4"	80-995-25-04

1/1

Beispielabbildung
Example illustration
Ilustración a modo de ejemplo
Illustration à titre d'exemple
Figura di esempio

KLS Martin **nonStick** red –

die bipolaren Pinzetten von KLS Martin mit ANTIHAFTEFFEKT und revolutionärer Ergonomie
the bipolar forceps from KLS Martin – with nonStick effect and a revolutionary ergonomic design
las pinzas bipolares de KLS Martin con efecto ANTIADHERENTE y ergonomía revolucionaria
les pincas bipolaires de KLS Martin à effet ANTI-ADHÉSIF et ergonomie révolutionnaire
le pinze bipolari di KLS Martin con effetto ANTIADERENTE ed ergonomía rivoluzionaria

Fußschalter

Foot switches

Interruptores de pie

Interrupteurs à pédale

Interruttori a pedale



80-811-50-04

Monopolarer und bipolarer Fußschalter, explosionsgeschützt, AP-geprüft, IP X8, eintauchbar

Monopolar and bipolar foot switch, anti-explosive, AP-tested (anesthetics-proof), IP X8, immersible

Interruptor de pie monopolar y bipolar, antiexplosivo, controlada su aptitud para anestésicos, IP X8, sumergible

Interrupteur à pédale monopolaire et bipolaire, anti-explosif, catégorie AP, IP X8, immergeable

Interruttore a pedale monopolare e bipolare, anti-deflagrante, testato AP, IP X8, immergibile

**ME 81 ME 82
ME 102**



80-824-01-04

Doppelpedal-Fußschalter, monopolar, explosionsgeschützt, AP-geprüft, IP X8, eintauchbar

Double-pedal foot switch, monopolar, explosion- and anesthetics-proof (AP-tested), IP X8, immersible

Interruptor de pie de doble pedal, monopolar, antiexplosivo, controlada su aptitud para anestésicos, IP X8, sumergible

Interrupteur à pédale double, monopolaire, anti-explosif, catégorie AP, IP X8, immergeable

Interruttore a pedale doppio, monopolare, anti-deflagrante, testato AP, IP X8, immergibile

**ME 81 (nur bipolar, bipolar only,
sólo bipolar, bipolaire uniquement,
solo bipolare)**

ME K1

ME K2

ME 82

miniCutter

**ME 102 (nur bipolar, bipolar only,
sólo bipolar, bipolaire uniquement,
solo bipolare)**



80-830-00-04

Doppelpedalfußschalter, 5 m Kabel, explosions-geschützt, AP-geprüft, IP X8, eintauchbar

Double-pedal foot switch, 5 m cable, explosion-proof, AP-tested, IP X8, immersible

Interruptor de pie de doble pedal, cable 5 m, antiexplosivo, controlada su aptitud para anestésicos, IP X8, sumergible

Interrupteur à pédale double, câble 5 m, anti-explosif, catégorie AP, IP X8, immergeable

Interruttore a pedale doppio, cavo 5 m, anti-deflagrante, testato AP, IP X8, immergibile

**ME 400/200 (nur monopolar,
monopolar only, sólo monopolar,
monopolaire uniquement,
solo monopolare)**

**ME 401/411 (nur monopolar,
monopolar only, sólo monopolar,
monopolaire uniquement, solo
monopolare)**

ME M1/ME MB 1

ME CD1

ME MB 3

ME MB 2

maXium®

maXium® smart C



80-830-01-04

SWAP-Mode-Doppelpedalfußschalter, 5 m Kabel, explosionsgeschützt, AP-geprüft, IP X8, eintauchbar

SWAP mode double-pedal foot switch, 5 m cable, explosion-proof, AP-tested, IP X8, immersible

Interruptor de pie de doble pedal con modo SWAP, cable 5 m, antiexplosivo, controlada su aptitud para anestésicos, IP X8, sumergible

Interrupteur à pédale double avec mode SWAP, câble 5 m, anti-explosif, catégorie AP, IP X8, immergeable

Interruttore a pedale doppio con modo SWAP, cavo 5 m, anti-deflagrante, testato AP, IP X8, immergibile

**ME 400/200 (nur monopolar,
monopolar only, sólo monopolar,
monopolaire uniquement,
solo monopolare)**

**ME 401/411 (nur monopolar,
monopolar only, sólo monopolar,
monopolaire uniquement, solo
monopolare)**

ME M1/ME MB 1

ME CD1

ME MB 3

ME MB 2

maXium®

maXium® smart C



Informationen zu den KLS-Martin-Elektrochirurgie-Systemen entnehmen Sie bitte den separaten Katalogen bzw. Broschüren:

- Zubehör für die Elektrochirurgie

Please refer to the separate catalogs and brochures for information about KLS-Martin electrosurgery systems:

- Electrosurgery accessories

Encontrará información sobre los sistemas de electrocirugía de KLS-Martin en los catálogos o folletos específicos:

- Accesorios para electrocirugía

Veuillez vous reporter aux catalogues ou brochures séparés pour obtenir des informations détaillées à propos des systèmes d'électrochirurgie KLS Martin:

- Accessoires d'électrochirurgie

Per informazioni sui sistemi di elettrochirurgia di KLS Martin, consultare i cataloghi e/o le brochure separati:

- Accessori per elettrochirurgia

Nummern-Index
Index of order numbers
ndice de n meros de referencia
Index numérique des références de commande
lenco dei codici



Nummern-Index

Index of order numbers

ndice de n meros de referencia

Index numérique des références de commande

lenco dei codici

10

10-040-01-07.....	2
10-040-02-07.....	2
10-040-03-07.....	2
10-040-04-07.....	2
10-040-05-07.....	2
10-096-00-07.....	3
10-104-41-07.....	3
10-108-08-07.....	3
10-130-03-07.....	3
10-133-31-07.....	3
10-133-35-07.....	3
10-137-07-07.....	4
10-137-71-07.....	4
10-146-03-07.....	4
10-149-01-07.....	4
10-149-02-07.....	4
10-149-05-07.....	5
10-149-06-07.....	5
10-149-07-07.....	5
10-155-10-04.....	6
10-155-11-04.....	6
10-155-12-04.....	6
10-155-15-04.....	6
10-155-21-04.....	6
10-155-23-04.....	6
10-156-12-04.....	6
10-156-15-04.....	6
10-160-01-07.....	5
10-199-00-01.....	6
10-878-00-07.....	7
10-878-01-07.....	7
10-880-00-07.....	7
10-880-01-07.....	7
10-880-02-07.....	7
10-882-19-07.....	7
10-882-90-98.....	7

11

11-104-13-07.....	12
11-109-14-07.....	12
11-110-01-07.....	12
11-110-02-07.....	12
11-110-03-07.....	12
11-110-04-07.....	12
11-170-14-07.....	13
11-170-17-07.....	13
11-170-23-07.....	13
11-171-14-07.....	14
11-171-17-07.....	14
11-171-23-07.....	14
11-180-15-07.....	15
11-180-17-07.....	15
11-181-15-07.....	16
11-181-17-07.....	16
11-226-16-07.....	17
11-227-16-07.....	18
11-248-11-07.....	19
11-249-11-07.....	20
11-250-14-07.....	19
11-255-14-07.....	20
11-280-18-07.....	23
11-280-20-07.....	23
11-280-23-07.....	23
11-280-25-07.....	23
11-280-28-07.....	23
11-280-30-07.....	23
11-284-18-07.....	22
11-284-20-07.....	22
11-285-18-07.....	24
11-285-20-07.....	24
11-285-23-07.....	24
11-285-25-07.....	24
11-285-28-07.....	24
11-285-30-07.....	24
11-306-12-07.....	22
11-306-19-07.....	22
11-307-19-07.....	22
11-308-17-07.....	22

11-310-16-07.....	26
11-311-16-07.....	27
11-317-11-07.....	29
11-317-14-07.....	29
11-320-10-07.....	30
11-321-10-07.....	30
11-326-14-07.....	31
11-327-14-07.....	32
11-328-14-07.....	34
11-329-14-07.....	35
11-329-18-07.....	35
11-329-20-07.....	35
11-330-18-07.....	31
11-330-20-07.....	31
11-330-23-07.....	31
11-331-18-07.....	32
11-331-20-07.....	32
11-331-23-07.....	32
11-335-18-07.....	36
11-335-20-07.....	36
11-335-23-07.....	36
11-344-11-07.....	37
11-345-11-07.....	37
11-350-14-07.....	38
11-351-14-07.....	39
11-352-14-07.....	40
11-353-14-07.....	40
11-354-14-07.....	41
11-355-14-07.....	41
11-358-13-07.....	42
11-359-12-07.....	43
11-359-15-07.....	43
11-359-18-07.....	43
11-359-20-07.....	43
11-364-14-07.....	44
11-364-15-07.....	44
11-364-18-07.....	44
11-365-14-07.....	45
11-365-15-07.....	45
11-365-18-07.....	45
11-370-01-07.....	46
11-370-02-07.....	46
11-371-01-07.....	46
11-371-02-07.....	46
11-371-03-07.....	46
11-371-04-07.....	46
11-371-05-07.....	46
11-371-06-07.....	46
11-371-07-07.....	46
11-371-08-07.....	46
11-459-17-07.....	47
11-495-17-07.....	48
11-505-16-07.....	51
11-507-15-07.....	49
11-508-12-07.....	50
11-509-10-07.....	50
11-509-13-07.....	50
11-509-14-07.....	50
11-509-16-07.....	51
11-509-18-07.....	54
11-510-20-07.....	53
11-511-10-07.....	50
11-511-18-07.....	52
11-513-13-07.....	54
11-513-14-07.....	55
11-513-18-07.....	53
11-514-19-07.....	54
11-566-13-07.....	56
11-567-13-07.....	56
11-618-08-07.....	57
11-619-08-07.....	57
11-620-09-07.....	57
11-620-10-07.....	57
11-621-09-07.....	57
11-621-10-07.....	57
11-630-11-07.....	58
11-631-11-07.....	59
11-640-12-07.....	60
11-641-12-07.....	60
11-642-11-07.....	60

11-643-11-07.....	60
11-644-13-07.....	61
11-645-13-07.....	61
11-652-14-07.....	13
11-652-17-07.....	13
11-652-23-07.....	13
11-653-14-07.....	14
11-653-17-07.....	14
11-653-23-07.....	14
11-654-15-07.....	15
11-654-17-07.....	15
11-655-15-07.....	16
11-655-17-07.....	16
11-656-16-07.....	17
11-657-16-07.....	18
11-658-11-07.....	19
11-658-14-07.....	19
11-659-11-07.....	20
11-659-14-07.....	20
11-660-18-07.....	23
11-660-20-07.....	23
11-660-23-07.....	23
11-660-26-07.....	23
11-660-28-07.....	23
11-660-31-07.....	23
11-661-18-07.....	24
11-661-20-07.....	24
11-661-23-07.....	24
11-661-26-07.....	24
11-661-28-07.....	24
11-661-31-07.....	24
11-662-10-07.....	30
11-662-16-07.....	26
11-663-10-07.....	30
11-663-16-07.....	27
11-665-14-07.....	32
11-665-18-07.....	32
11-665-20-07.....	32
11-665-23-07.....	32
11-666-14-07.....	38
11-667-14-07.....	39
11-669-12-07.....	43
11-669-15-07.....	43
11-670-18-07.....	43
11-671-15-07.....	45
11-671-18-07.....	45
11-672-10-07.....	58
11-672-11-07.....	58
11-673-10-07.....	59
11-673-11-07.....	59
11-674-10-07.....	63
11-675-10-07.....	63
11-676-10-07.....	62
11-677-10-07.....	62
11-678-10-07.....	62
11-679-10-07.....	62
11-680-11-07.....	63
11-681-11-07.....	63
11-682-11-07.....	62
11-683-11-07.....	62
11-690-11-07.....	64
11-691-11-07.....	64
11-710-15-07.....	65
11-710-18-07.....	65
11-710-19-07.....	65
11-711-15-07.....	65
11-711-18-07.....	65
11-711-19-07.....	65
11-711-20-07.....	65
11-712-15-07.....	65
11-712-18-07.....	65
11-712-19-07.....	65
11-713-15-07.....	65
11-713-18-07.....	65
11-713-19-07.....	65
11-713-20-07.....	65
11-758-12-07.....	66
11-760-09-07.....	66
11-761-09-07.....	66
11-765-18-07.....	66

11-767-18-07.....	66
11-769-18-07.....	66
11-801-10-07.....	67
11-809-11-07.....	67
11-821-09-07.....	67
11-824-09-07.....	67
11-824-10-07.....	67
11-826-13-07.....	67
11-830-14-07.....	68
11-830-18-07.....	68
11-834-14-07.....	68
11-874-10-07.....	68
11-875-10-07.....	68
11-878-12-07.....	68
11-879-12-07.....	68
11-887-11-07.....	21
11-887-18-07.....	25
11-887-20-07.....	25
11-887-23-07.....	25
11-887-25-07.....	25
11-887-30-07.....	25
11-889-14-07.....	33
11-889-18-07.....	33
11-893-17-07.....	47
11-895-16-07.....	28
11-910-14-07.....	13
11-910-17-07.....	13
11-910-23-07.....	13
11-911-14-07.....	14
11-911-17-07.....	14
11-911-23-07.....	14
11-914-14-07.....	69
11-914-18-07.....	69
11-914-20-07.....	69
11-914-23-07.....	69
11-914-25-07.....	69
11-914-30-07.....	69
11-915-14-07.....	70
11-915-17-07.....	70
11-915-23-07.....	70
11-916-14-07.....	71
11-916-18-07.....	71
11-916-20-07.....	71
11-917-11-07.....	21
11-917-18-07.....	25
11-917-20-07.....	25
11-917-23-07.....	25
11-917-25-07.....	25
11-917-30-07.....	25
11-919-14-07.....	71
11-919-18-07.....	71
11-921-17-07.....	47
11-923-16-07.....	28
11-930-15-07.....	15
11-930-17-07.....	15
11-931-15-07.....	16
11-931-17-07.....	16
11-934-12-07.....	72
11-935-12-07.....	72
11-936-11-07.....	19
11-937-11-07.....	20
11-938-14-07.....	19
11-939-14-07.....	20
11-942-18-07.....	23
11-942-20-07.....	23
11-942-23-07.....	23
11-942-25-07.....	23
11-942-28-07.....	23
11-942-30-07.....	23
11-943-18-07.....	24
11-943-20-07.....	24
11-943-23-07.....	24
11-943-25-07.....	24
11-943-28-07.....	24
11-943-30-07.....	24
11-945-20-07.....	73
11-945-23-07.....	73
11-945-28-07.....	73
11-948-14-07.....	38
11-949-14-07.....	39

11-950-10-07.....	73
11-950-16-07.....	26
11-950-21-07.....	26
11-951-10-07.....	73
11-951-16-07.....	27
11-951-21-07.....	27
11-953-16-07.....	74
11-954-14-07.....	31
11-955-14-07.....	32
11-956-14-07.....	34
11-957-14-07.....	35
11-960-18-07.....	31
11-961-18-07.....	32
11-961-20-07.....	32
11-961-23-07.....	32
11-962-18-07.....	34
11-962-20-07.....	34
11-962-23-07.....	34
11-965-17-07.....	47
11-967-18-07.....	36
11-967-20-07.....	36
11-967-23-07.....	36
11-968-11-07.....	75
11-969-11-07.....	75
11-969-17-07.....	76
11-969-19-07.....	76
11-969-23-07.....	76
11-970-19-07.....	77
11-970-23-07.....	77
11-971-19-07.....	77
11-971-23-07.....	77
11-973-17-07.....	78
11-974-23-07.....	79
11-980-13-07.....	56
11-981-13-07.....	56
11-982-11-07.....	58, 74
11-983-11-07.....	59
11-991-12-07.....	80
11-991-15-07.....	80
11-991-18-07.....	80
11-992-16-07.....	17
11-993-16-07.....	18
11-996-16-07.....	81
12-166-12-07.....	94
12-168-12-07.....	94
12-168-15-07.....	94
12-170-15-07.....	94
12-171-20-07.....	94
12-172-12-07.....	94
12-172-15-07.....	94
12-184-06-07.....	95
12-184-08-07.....	95
12-184-10-07.....	95
12-184-18-07.....	95
12-246-12-07.....	96
12-246-15-07.....	96
12-250-12-07.....	96
12-250-15-07.....	96
12-276-18-07.....	96
12-278-18-07.....	96
12-279-18-07.....	96
12-326-14-07.....	97
12-368-12-07.....	97
12-368-15-07.....	97
12-370-15-07.....	97
12-371-20-07.....	97
12-371-25-07.....	97
12-372-12-07.....	97
12-372-15-07.....	97
12-384-06-07.....	98
12-384-08-07.....	98
12-384-10-07.....	98
12-400-12-07.....	98
12-402-12-07.....	98
12-406-12-07.....	98
12-406-15-07.....	98
12-466-23-07.....	98
12-552-01-07.....	99
12-552-02-07.....	99
12-552-03-07.....	99

Nummern-Index

Index of order numbers

ndice de n meros de referencia

Index numérique des références de commande

lenco dei codici

20-031-23-07.....	139
20-031-23-09.....	139
20-032-15-07.....	139
20-032-15-09.....	139
20-032-18-07.....	139
20-032-18-09.....	139
20-032-21-07.....	139
20-032-21-09.....	139
20-032-23-07.....	139
20-032-23-09.....	139
20-033-15-07.....	139
20-033-15-09.....	139
20-033-18-07.....	139
20-033-18-09.....	139
20-033-21-07.....	139
20-033-21-09.....	139
20-033-23-07.....	139
20-033-23-09.....	139
20-048-18-07.....	140
20-049-18-07.....	140
20-050-18-07.....	140
20-051-18-07.....	140
20-299-10-07.....	140
20-299-11-07.....	140
20-300-11-07.....	141
20-300-13-07.....	141
20-300-14-07.....	141
20-301-13-07.....	141
20-302-01-07.....	141
20-303-09-07.....	141
20-304-09-07.....	141
20-305-09-07.....	141
20-306-14-07.....	142
20-307-14-07.....	142
20-308-14-07.....	142
20-309-14-07.....	142
20-310-14-07.....	142
20-311-14-07.....	142
20-313-14-07.....	142
20-328-12-07.....	143
20-332-12-07.....	143
20-338-13-07.....	143
20-390-14-07.....	144
20-390-18-07.....	144
20-390-20-07.....	144
20-390-24-07.....	144
20-396-16-07.....	144
20-396-18-07.....	144
20-396-20-07.....	144
20-469-16-07.....	144
20-602-18-07.....	145
20-604-13-07.....	145
20-604-15-07.....	145
20-605-15-07.....	145
20-605-18-07.....	145
20-605-21-07.....	145
20-605-23-07.....	145
20-606-15-07.....	145
20-606-18-07.....	145
20-606-21-07.....	145
20-606-23-07.....	145
20-607-15-07.....	145
20-607-18-07.....	145
20-607-21-07.....	145
20-607-23-07.....	145
20-608-15-07.....	145
20-608-18-07.....	145
20-608-21-07.....	145
20-608-23-07.....	145
20-610-18-07.....	146
20-613-19-07.....	146
20-613-23-07.....	146
20-614-01-07.....	147
20-614-02-07.....	147
20-614-03-07.....	147
20-614-04-07.....	147
20-615-01-07.....	147
20-615-02-07.....	147
20-615-03-07.....	147
20-615-04-07.....	147

20-620-00-07.....	148
20-620-01-07.....	148
20-620-14-07.....	148
20-620-18-07.....	148
20-620-21-07.....	148
20-621-14-07.....	148
20-621-18-07.....	148
20-621-21-07.....	148
20-632-12-07.....	148
20-636-13-07.....	148
20-637-13-07.....	148
20-638-20-07.....	149
20-642-16-07.....	149
20-642-18-07.....	149
20-642-20-07.....	149
20-642-24-07.....	149
20-642-26-07.....	149
20-642-30-07.....	149
20-646-18-07.....	150
20-646-20-07.....	150
20-646-23-07.....	150
20-646-26-07.....	150
20-646-31-07.....	150
20-652-15-07.....	150
20-652-17-07.....	150
20-659-20-07.....	151
20-659-24-07.....	151
20-659-26-07.....	151
20-659-28-07.....	151
20-666-05-07.....	151
20-673-15-07.....	152
20-673-16-07.....	152
20-676-14-07.....	152
20-676-17-07.....	152
20-676-20-07.....	152

22

22-500-15-07.....	154
22-500-20-07.....	154
22-511-01-07.....	154
22-518-16-07.....	154
22-522-16-07.....	154
22-523-16-07.....	155
22-523-22-07.....	155
22-523-25-07.....	155
22-523-81-98.....	155
22-526-18-07.....	156
22-527-02-05.....	156
22-527-03-05.....	156
22-527-04-05.....	156
22-527-05-05.....	156
22-527-06-05.....	156
22-527-07-05.....	156
22-527-08-05.....	156
22-527-09-05.....	156
22-527-10-05.....	156
22-527-12-05.....	156
22-527-15-05.....	156
22-596-01-07.....	124, 156
22-596-02-07.....	124, 156
22-596-03-07.....	124, 156
22-618-00-07.....	156
22-618-90-98.....	156
22-622-16-05.....	157
22-623-16-05.....	157
22-625-16-05.....	157
22-626-16-05.....	157
22-627-16-05.....	157
22-628-16-05.....	157
22-629-16-05.....	157
22-630-16-05.....	157
22-631-16-05.....	157
22-632-16-05.....	157
22-633-16-05.....	157

23

23-190-05-07.....	158
23-190-06-07.....	158
23-192-00-71.....	158
23-215-19-07.....	159
23-218-22-04.....	159
23-240-29-04.....	160, 161
23-244-24-04.....	160
23-253-22-04.....	160, 161
23-254-22-04.....	160, 161
23-256-00-04.....	160, 161
23-260-01-04.....	162
23-262-19-04.....	162
23-262-90-98.....	162
23-264-19-04.....	162
23-434-13-07.....	163
23-436-07-07.....	163
23-436-16-07.....	163
23-441-17-07.....	164
23-443-17-07.....	164
23-721-15-07.....	164
23-960-01-04.....	165
23-960-02-04.....	165
23-960-24-04.....	165
23-960-27-04.....	165
23-960-44-04.....	165
23-962-00-07.....	166
23-963-00-04.....	167
23-963-01-04.....	167
23-963-02-04.....	167

24

24-384-16-07.....	104
24-384-20-07.....	104
24-389-16-07.....	104
24-389-20-07.....	104
24-438-12-07.....	108
24-439-12-07.....	108
24-541-20-07.....	112
24-823-20-07.....	112
24-824-20-07.....	112
24-835-13-07.....	112
24-835-18-07.....	112
24-850-01-07.....	82
24-850-02-07.....	82
24-850-03-07.....	82
24-850-04-07.....	82
24-850-05-07.....	82
24-850-10-07.....	82
24-850-11-07.....	82
24-850-15-07.....	82
24-850-20-07.....	83
24-850-21-07.....	83
24-850-22-07.....	83
24-850-23-07.....	83
24-850-24-07.....	83
24-850-25-07.....	83
24-850-26-07.....	83
24-850-28-07.....	83
24-850-30-07.....	83
24-850-31-07.....	83
24-850-32-07.....	83
24-850-33-07.....	83
24-850-50-07.....	84
24-850-60-07.....	84
24-851-10-07.....	152
24-851-11-07.....	152
24-851-12-07.....	152
24-851-13-07.....	152
24-852-01-07.....	103
24-852-02-07.....	103
24-852-10-07.....	103
24-852-11-07.....	103
24-852-12-07.....	103
24-852-25-07.....	103
24-852-26-07.....	103
24-852-70-07.....	103
24-852-71-07.....	103
24-852-72-07.....	103

24-852-73-07.....	103
24-852-74-07.....	103
24-852-75-07.....	103
24-852-76-07.....	103

27

27-155-17-07.....	113
-------------------	-----

28

28-100-02-07.....	170
28-100-03-07.....	170
28-100-04-07.....	170
28-100-05-07.....	171
28-100-06-07.....	171
28-100-07-07.....	172
28-100-10-07.....	172
28-100-11-07.....	172
28-100-12-07.....	172
28-100-13-07.....	172
28-120-00-07.....	136
28-135-14-07.....	173
28-188-01-07.....	173
28-188-02-07.....	173
28-188-03-07.....	173
28-188-04-07.....	173
28-196-01-07.....	173
28-196-02-07.....	173
28-196-03-07.....	173
28-196-04-07.....	173
28-196-05-07.....	173
28-196-06-07.....	173
28-203-15-07.....	174
28-207-18-07.....	174
28-209-18-07.....	174
28-215-03-07.....	174
28-215-04-07.....	174
28-240-02-07.....	174
28-240-03-07.....	174
28-240-04-07.....	174
28-240-05-07.....	174
28-240-06-07.....	174
28-240-07-07.....	174
28-240-08-07.....	174
28-261-14-07.....	175
28-263-14-07.....	175
28-271-10-07.....	175
28-275-14-07.....	175
28-279-10-07.....	175
28-294-14-07.....	175
28-296-11-07.....	175
28-298-16-07.....	176
28-300-15-07.....	176
28-370-12-07.....	176
28-371-12-07.....	176
28-372-16-07.....	176
28-400-11-07.....	85
28-400-13-07.....	61
28-401-11-07.....	85
28-401-13-07.....	61
28-402-10-07.....	85
28-402-11-07.....	86
28-403-09-07.....	86
28-403-10-07.....	85
28-403-11-07.....	86
28-404-11-07.....	86
28-404-12-07.....	72
28-405-11-07.....	86
28-405-12-07.....	72
28-406-11-07.....	86
28-407-11-07.....	86
28-408-14-07.....	13
28-408-17-07.....	13
28-409-14-07.....	14
28-409-17-07.....	14
28-410-16-07.....	26
28-411-16-07.....	27
28-413-15-07.....	16
28-413-17-07.....	16

28-415-11-07.....	87
28-417-13-07.....	87
28-417-15-07.....	87
28-417-18-07.....	87
28-418-14-07.....	40
28-419-14-07.....	40
28-420-14-07.....	41
28-421-14-07.....	41
28-422-14-07.....	34
28-423-14-07.....	35
28-423-18-07.....	35
28-424-11-07.....	19
28-424-14-07.....	19
28-424-18-07.....	23
28-424-20-07.....	23
28-425-11-07.....	20
28-425-14-07.....	20
28-425-18-07.....	24
28-425-20-07.....	24
28-426-23-07.....	23
28-426-26-07.....	23
28-426-30-07.....	23
28-427-23-07.....	24
28-427-26-07.....	24
28-427-30-07.....	24
28-428-14-07.....	31
28-428-18-07.....	31
28-428-20-07.....	31
28-428-23-07.....	31
28-429-14-07.....	33
28-429-18-07.....	33
28-429-20-07.....	33
28-429-23-07.....	33
28-429-26-07.....	33
28-429-28-07.....	33
28-431-18-07.....	36
28-431-20-07.....	36
28-431-23-07.....	36
28-432-15-07.....	38
28-433-15-07.....	39
28-434-16-07.....	17
28-435-16-07.....	18
28-437-18-07.....	47
28-439-12-07.....	88
28-439-16-07.....	88
28-439-18-07.....	88
28-441-13-07.....	88
28-443-17-07.....	88
28-443-19-07.....	88
28-445-17-07.....	76
28-447-23-07.....	79
28-449-17-07.....	89
28-449-23-07.....	89
28-450-13-07.....	89
28-451-13-07.....	89
28-453-18-07.....	52
28-455-14-07.....	55
28-457-12-07.....	89
28-459-13-07.....	49
28-461-16-07.....	51
28-463-17-07.....	48
28-464-11-07.....	58
28-465-11-07.....	59
28-466-14-07.....	13
28-466-17-07.....	13
28-467-14-07.....	14
28-467-17-07.....	14
28-468-16-07.....	26
28-469-16-07.....	27
28-471-15-07.....	16
28-471-17-07.....	16
28-472-20-07.....	23
28-472-23-07.....	23
28-473-18-07.....	36
28-473-20-07.....	36
28-473-23-07.....	36
28-474-16-07.....	17
28-475-16-07.....	18
28-477-18-07.....	47
28-479-16-07.....	51

28-481-13-07.....	49	37-628-03-07.....	201	37-724-03-07.....	213	38-616-20-07.....	230
28-499-17-07.....	90	37-632-20-07.....	202	37-725-23-07.....	213	38-618-10-07.....	231
28-499-19-07.....	90	37-634-20-07.....	202	37-731-14-07.....	214	38-618-20-07.....	231
28-499-23-07.....	90	37-649-00-07.....	202	37-732-10-07.....	214	38-620-10-07.....	232
28-501-14-07.....	91	37-649-01-07.....	202	37-748-01-07.....	214	38-620-20-07.....	232
28-503-15-07.....	91	37-649-02-07.....	202	37-748-02-07.....	214	38-630-06-07.....	233
28-503-18-07.....	91	37-652-00-07.....	203	37-748-03-07.....	214	38-630-07-07.....	233
28-505-18-07.....	91	37-652-01-07.....	203	37-748-04-07.....	214	38-630-09-07.....	233
28-521-18-07.....	92	37-652-02-04.....	203	37-748-05-07.....	214	38-630-11-07.....	233
28-525-18-07.....	92	37-656-01-07.....	204	37-748-06-07.....	214	38-631-05-07.....	233
28-529-23-07.....	92	37-656-02-07.....	204	37-755-01-07.....	215	38-631-07-07.....	233
		37-658-01-07.....	204	37-755-02-07.....	215	38-631-09-07.....	233
35		37-669-18-04.....	204	37-755-03-07.....	215	38-632-01-07.....	234
35-133-07-07.....	178	37-670-21-07.....	204	37-755-04-07.....	215	38-632-02-07.....	234
35-133-09-07.....	178	37-671-21-07.....	205	37-755-05-07.....	215	38-633-01-07.....	234
35-134-09-07.....	178	37-673-21-07.....	205	37-755-06-07.....	215	38-633-02-07.....	234
		37-674-18-07.....	205	37-756-01-07.....	215	38-633-03-07.....	234
36		37-676-18-07.....	205	37-756-02-07.....	215	38-633-04-07.....	234
36-395-16-07.....	180	37-680-01-07.....	206	37-756-03-07.....	215	38-640-21-07.....	235
36-845-01-07.....	180	37-680-02-07.....	206	37-756-04-07.....	215	38-642-21-07.....	235
36-845-02-07.....	180	37-680-03-07.....	206	37-756-05-07.....	215	38-690-00-07.....	235
36-845-03-07.....	180	37-680-04-07.....	206	37-756-06-07.....	215	38-694-20-07.....	235
36-848-13-07.....	181	37-680-05-07.....	206	37-814-30-07.....	216	38-700-01-07.....	236
36-852-13-07.....	181	37-680-06-07.....	206	37-816-30-07.....	216	38-700-02-07.....	236
36-856-01-07.....	181	37-680-07-07.....	206	37-840-20-01.....	216	38-700-03-07.....	236
36-856-02-07.....	181	37-680-08-07.....	206	37-840-90-98.....	216	38-701-01-07.....	236
36-856-03-07.....	181	37-680-09-07.....	206			38-701-02-07.....	236
36-856-04-07.....	181	37-680-10-07.....	206	38		38-701-03-07.....	236
36-858-14-07.....	182	37-680-21-07.....	205	38-018-01-07.....	218	38-711-01-01.....	237
36-859-35-07.....	182	37-681-01-07.....	207	38-130-50-07.....	219	38-711-02-01.....	237
36-859-50-07.....	182	37-681-02-07.....	207	38-130-52-07.....	219	38-715-19-07.....	237
36-859-75-07.....	182	37-681-03-07.....	207	38-130-54-07.....	219	38-723-16-07.....	237
36-859-90-07.....	182	37-681-04-07.....	207	38-130-56-07.....	219	38-781-00-07.....	238
		37-681-05-07.....	207	38-130-58-07.....	219	38-781-01-07.....	238
		37-681-06-07.....	207	38-161-11-07.....	220	38-783-01-07.....	238
		37-681-07-07.....	207	38-161-14-07.....	220	38-790-04-07.....	238
		37-681-08-07.....	207	38-171-12-07.....	220	38-790-06-07.....	238
		37-681-09-07.....	207	38-179-16-07.....	220	38-790-08-07.....	238
		37-681-10-07.....	207	38-179-20-07.....	220	38-791-01-07.....	238
		37-681-11-07.....	207	38-198-00-07.....	221	38-791-03-07.....	238
		37-681-12-07.....	207	38-198-01-07.....	221	38-796-04-07.....	239
		37-681-13-07.....	207	38-198-02-07.....	221	38-796-06-07.....	239
		37-682-01-07.....	208	38-198-03-07.....	221	38-796-08-07.....	239
		37-682-02-07.....	208	38-198-10-07.....	221	38-797-04-07.....	239
		37-682-03-07.....	208	38-198-90-98.....	221	38-797-06-07.....	239
		37-682-04-07.....	208	38-208-00-07.....	222	38-799-06-07.....	239
		37-682-05-07.....	208	38-208-01-07.....	222	38-799-08-07.....	239
		37-682-06-07.....	208	38-208-02-07.....	222	38-831-01-07.....	240
		37-683-00-07.....	209	38-208-03-07.....	222	38-831-02-07.....	240
		37-683-01-07.....	209	38-208-10-07.....	222	38-833-18-07.....	240
		37-683-02-07.....	209	38-222-00-07.....	223	38-835-19-07.....	240
		37-684-15-07.....	209	38-222-01-07.....	223	38-837-01-07.....	241
		37-688-01-07.....	209	38-222-02-07.....	223	38-837-02-07.....	241
		37-688-02-07.....	209	38-222-03-07.....	223	38-837-03-07.....	241
		37-688-03-07.....	209	38-222-10-07.....	223	38-837-04-07.....	241
		37-692-22-07.....	209	38-224-00-07.....	224	38-839-18-07.....	242
		37-694-17-07.....	209	38-224-01-07.....	224	38-841-22-07.....	242
		37-697-19-07.....	209	38-224-02-07.....	224	38-845-01-07.....	243
		37-698-10-07.....	210	38-224-03-07.....	224	38-845-02-07.....	243
		37-700-12-07.....	210	38-243-11-01.....	225	38-846-20-07.....	243
		37-702-15-07.....	210	38-246-14-04.....	225	38-850-01-07.....	244
		37-704-02-07.....	210	38-249-14-01.....	225	38-850-02-07.....	244
		37-704-05-07.....	210	38-263-15-01.....	225	38-851-16-07.....	245
		37-704-07-07.....	210	38-271-15-07.....	226	38-853-24-07.....	245
		37-704-10-07.....	210	38-277-14-07.....	226	38-856-19-07.....	245
		37-705-01-07.....	210	38-297-01-01.....	226	38-870-17-07.....	246
		37-706-16-07.....	210	38-297-02-01.....	226	38-877-00-07.....	246
		37-707-20-07.....	211	38-603-40-07.....	227	38-878-01-07.....	247
		37-707-21-07.....	211	38-603-55-07.....	227	38-878-02-07.....	247
		37-708-14-07.....	211	38-603-80-07.....	227	38-881-07-07.....	248
		37-709-01-07.....	211	38-605-22-07.....	227	38-881-10-07.....	248
		37-709-02-07.....	211	38-607-22-07.....	228	38-883-07-07.....	249
		37-710-14-07.....	212	38-611-16-07.....	228	38-883-11-07.....	249
		37-712-16-07.....	212	38-613-08-07.....	228	38-883-15-07.....	249
		37-713-15-07.....	212	38-613-10-07.....	228	38-885-18-07.....	249
		37-714-15-07.....	212	38-614-10-07.....	229	38-893-16-07.....	250
		37-715-14-07.....	212	38-614-20-07.....	229	38-895-05-07.....	250
		37-721-20-07.....	213	38-616-01-07.....	228	38-895-08-07.....	250
		37-724-01-07.....	213	38-616-02-07.....	228	38-899-06-07.....	250
		37-724-02-07.....	213	38-616-10-07.....	230	38-899-08-07.....	250

Nummern-Index

Index of order numbers

ndice de n meros de referencia

Index numérique des références de commande

lenco dei codici

46

46-528-01-07.....251

47

47-606-13-07.....251

47-608-13-07.....251

48

48-101-16-07.....252

48-101-25-07.....252

48-101-35-07.....252

48-101-42-07.....252

48-101-55-07.....252

48-101-70-07.....252

48-101-80-07.....252

48-103-16-07.....253

48-103-25-07.....253

48-103-35-07.....253

48-103-42-07.....253

48-103-55-07.....253

48-103-70-07.....253

48-103-80-07.....253

48-107-22-07.....254

48-109-22-07.....254

48-111-22-07.....254

48-113-22-07.....254

48-121-08-07.....255

48-121-10-07.....255

48-125-15-07.....255

48-130-06-07.....256

48-130-07-07.....256

48-130-09-07.....256

48-130-11-07.....256

48-132-06-07.....256

48-132-07-07.....256

48-132-09-07.....256

48-132-11-07.....256

48-135-21-07.....257

48-137-21-07.....257

48-140-01-07.....257

48-140-02-07.....257

48-150-01-07.....257

48-150-02-07.....257

48-152-05-07.....258

48-152-07-07.....258

48-152-09-07.....258

48-156-04-07.....258

48-156-06-07.....258

48-156-08-07.....258

48-161-08-04.....259

48-161-12-04.....259

48-161-16-04.....259

48-163-01-07.....260

48-163-02-07.....260

48-164-15-07.....261

48-164-20-07.....261

48-165-08-04.....262

48-165-12-04.....262

48-165-16-04.....262

48-165-20-04.....262

48-166-08-07.....263

48-166-11-07.....263

48-167-08-07.....263

48-167-11-07.....263

48-168-03-07.....264

48-168-04-07.....264

48-168-06-07.....264

48-168-08-07.....264

48-170-23-07.....264

48-196-14-07.....265

48-220-01-07.....265

48-220-02-07.....265

48-220-03-07.....265

48-250-19-07.....266

48-252-13-07.....266

48-261-30-07.....267

48-261-45-07.....267

48-261-70-07.....267

48-270-02-07.....268

48-270-03-07.....268

48-270-05-07.....268

48-270-07-07.....268

48-270-10-07.....268

48-270-14-07.....268

48-270-16-07.....268

48-271-05-07.....268

48-271-07-07.....268

48-271-10-07.....268

48-272-18-07.....268

48-273-10-07.....268

48-274-10-07.....269

48-274-15-07.....269

48-274-20-07.....269

48-274-30-07.....269

48-275-10-07.....269

48-275-15-07.....269

48-276-10-07.....269

48-276-15-07.....269

48-277-04-07.....269

48-277-15-07.....269

48-285-20-07.....270

48-285-28-07.....270

48-287-01-07.....271

48-287-02-07.....271

48-287-03-07.....271

48-287-04-07.....271

48-291-15-07.....272

48-293-19-07.....272

48-300-20-07.....272

48-301-21-07.....272

48-303-22-07.....272

48-311-01-07.....273

48-311-02-07.....273

48-313-01-07.....273

48-313-02-07.....273

48-330-01-07.....273

48-331-01-07.....274

48-331-02-07.....274

48-331-03-07.....274

48-331-04-07.....274

48-331-05-07.....274

48-333-03-07.....275

48-333-04-07.....275

48-333-05-07.....275

48-335-01-07.....276

48-335-02-07.....276

48-335-03-07.....276

48-335-04-07.....276

48-335-05-07.....276

48-335-06-07.....276

48-340-18-07.....277

48-341-18-07.....277

48-350-24-07.....277

48-351-13-07.....278

48-352-14-07.....278

48-354-16-07.....278

48-360-01-07.....279

48-360-02-07.....279

48-362-01-07.....279

48-362-02-07.....279

48-370-26-07.....280

48-371-18-07.....280

48-376-18-07.....280

48-400-07-07.....281

48-400-12-07.....281

48-402-02-07.....281

48-402-03-07.....281

48-402-05-07.....281

48-405-00-07.....282

48-405-01-07.....282

48-420-00-07.....282

48-500-18-07.....282

48-506-20-07.....282

48-525-23-07.....283

48-531-19-07.....283

48-541-60-07.....283

48-703-19-07.....284

48-704-22-07.....284

48-705-14-07.....285

48-706-18-07.....285

48-707-14-07.....285

48-708-01-07.....286

48-708-14-07.....286

48-709-18-07.....286

48-711-22-07.....287

48-711-23-07.....287

48-711-24-07.....287

48-711-25-07.....287

48-712-12-07.....287

48-714-20-07.....288

48-715-42-07.....288

48-716-22-07.....288

48-716-42-07.....288

48-716-55-07.....288

48-717-42-07.....289

48-723-22-07.....289

48-725-18-07.....289

48-727-20-07.....290

48-728-18-07.....290

48-728-19-07.....290

48-729-55-07.....291

48-731-14-07.....291

48-731-22-07.....292

48-731-25-07.....292

48-735-19-07.....292

48-738-12-07.....292

48-738-13-07.....293

48-739-18-07.....293

48-740-20-07.....293

48-756-15-07.....294

50

50-425-05-07.....297

50-425-11-07.....297

50-425-12-07.....297

50-425-13-07.....297

50-425-14-07.....297

50-425-15-07.....297

50-425-16-07.....297

50-425-17-07.....297

50-425-18-07.....297

50-425-19-07.....297

50-425-20-07.....297

50-425-21-07.....297

50-425-22-07.....297

50-425-23-07.....297

50-425-24-07.....297

50-425-25-07.....297

50-425-26-07.....297

50-425-27-07.....297

50-440-04-07.....295

50-440-06-07.....295

50-440-08-07.....295

50-441-06-07.....295

50-446-19-07.....295

50-450-17-07.....295

50-600-00-04.....296

55

55-962-37-04.....296

55-963-29-04.....296

55-964-31-04.....296

55-964-32-04.....296

55-997-01-04.....308

56

56-231-04-01.....308

56-231-06-01.....308

56-231-08-01.....308

56-231-11-01.....308

56-231-12-01.....308

56-231-14-01.....308

56-231-16-01.....308

56-231-18-01.....308

76

76-100-05-04.....310

76-100-06-04.....310

76-500-31-04.....310

76-500-49-04.....311, 313

76-500-50-04.....310

76-500-51-04.....310

76-500-60-04.....310, 313

76-500-61-04.....310

76-501-08-04.....311

76-502-01-04.....311

76-800-00-04.....312

76-810-00-04.....312

77

77-025-11-04.....313

79

79-100-57-04.....311

79-311-00-04.....312

79-311-02-04.....312

79-311-03-04.....312

79-311-10-04.....312

80

80-008-03-04.....317

KLS Martin Group

KLS Martin Australia Pty Ltd.

Sydney · Australia
Tel. +61 2 9439 5316
australia@klsmartin.com

KLS Martin do Brasil Ltda.

São Paulo · Brazil
Tel. +55 11 3554 2299
brazil@klsmartin.com

KLS Martin Medical (Shanghai) International Trading Co., Ltd

Shanghai · China
Tel. +86 21 5820 6251
info@klsmartin.com

KLS Martin India Pvt Ltd.

Chennai · India
Tel. +91 44 66 442 300
india@klsmartin.com

KLS Martin Italia S.r.l.

Milan · Italy
Tel. +39 039 605 67 31
info@klsmartin.com

KLS Martin Japan K.K.

Tokyo · Japan
Tel. +81 3 3814 1431
info@klsmartin.com

KLS Martin SE Asia Sdn. Bhd.

Penang · Malaysia
Tel. +604 261 7060
malaysia@klsmartin.com

KLS Martin de México, S.A. de C.V.

Mexico City · Mexico
Tel. +52 55 7572 0944
mexico@klsmartin.com

KLS Martin Nederland B.V.

Huizen · Netherlands
Tel. +31 35 523 45 38
infonl@klsmartin.com

KLS Martin SE & Co. KG

Moscow · Russia
Tel. +7 499 792 76 19
russia@klsmartin.com

KLS Martin Taiwan Ltd.

Taipei · Taiwan
Tel. +886 2 2325 3169
taiwan@klsmartin.com

KLS Martin SE & Co. KG

Dubai · United Arab Emirates
Tel. +971 4 454 16 55
middleeast@klsmartin.com

KLS Martin UK Ltd.

Reading · United Kingdom
Tel. +44 118 467 1500
info.uk@klsmartin.com

KLS Martin LP

Jacksonville · Florida, USA
Tel. +1 904 641 77 46
usa@klsmartin.com

KLS Martin SE Asia Sdn. Bhd.

Hanoi · Vietnam
Tel. +49 7461 706-0
vietnam@klsmartin.com

KLS Martin SE & Co. KG

A company of the KLS Martin Group

KLS Martin Platz 1 · 78532 Tuttlingen · Germany
PO Box 60 · 78501 Tuttlingen · Germany
Tel. +49 7461 706-0 · Fax +49 7461 706-193
info@klsmartin.com · www.klsmartin.com